

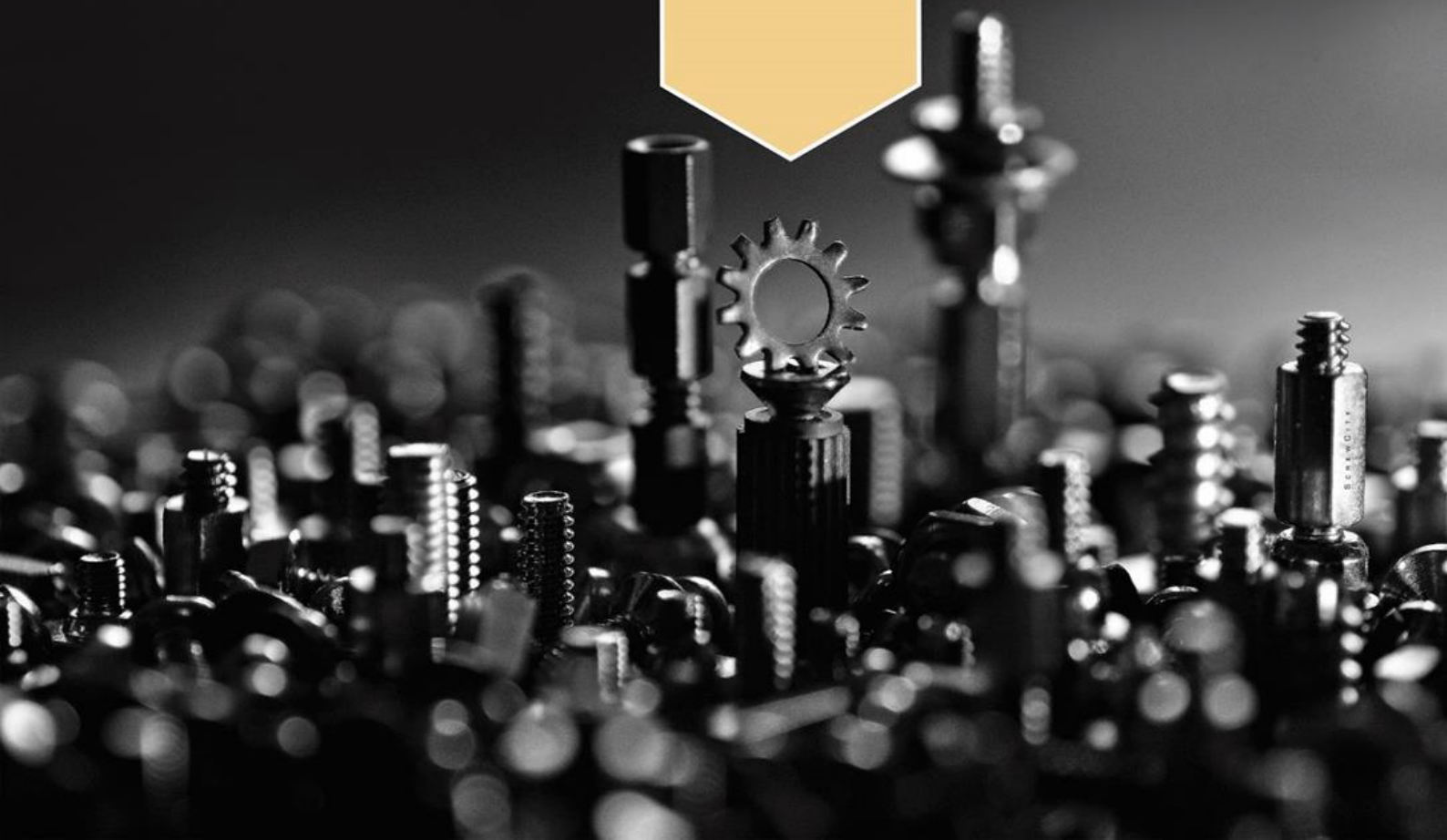

INVAYEAR







Invayear has been established with the motive to become one of the leading manufacturers, exporters and suppliers of Fasteners and Brass Fitting Components. Today, we are manufacturing and supplying quality Brass, Copper, Mild Steel, Stainless Steel and Plastic products catering to Electronics, Electrical, Builders Hardware, Bathroom Fittings and all other Industrial Sectors in India and across the globe. Our valued clientele is spread across the United States, European Union, Australia, New Zealand, Singapore, Malaysia and other South East and Middle East countries.

We are currently engaged in manufacturing Brass and Copper Extruded Rods, Profiles, Sections, Turned and Forged Components for Electrical Wiring and Earthing Accessories, Pipe Fittings and Connector Parts, Electrical Contacts, Battery Terminals, Fasteners with Wall Plugs, Panel Boards, other Door Hinges and other Hardware Fittings as per International standards, customer specified drawings or samples.

From the very beginning, our main aim has been to achieve maximum customer satisfaction by manufacturing components of the most superior quality, delivering them on time and at the most competitive prices. Our strong and dedicated management and workforce has given us an international benchmark to operate in the most professional, cost effective, channelized and systematized environments enabling us to add value to our products at all stages of production.





A1

A1 stainless steel is a free-machining variant of stainless steel. A1 stainless steel lacks the harsh environmental resistance of other high-performance marine grades of stainless steel. A1 Stainless Steel is an equivalent to SAE 303 or EN 1.4305 stainless steel.

A2

A2 stainless steel is the most widely used grade of stainless steel in European fasteners. A2 stainless steel is suitable for the vast majority of applications. A2 stainless steel is interchangeable with EN 1.4301, SAE 304, and UNS S30400.

A4

A4 stainless steel is known as a marine grade of stainless steel. This grade of steel has a slightly higher chrome and molybdenum content than A2 stainless steel, which gives it increased resistance in harsh chemical and outdoor environments. A4 marine grade stainless steel is an equivalent to EN 1.4401, EN 1.4436, SAE 316, and UNS S31600.

A4-80

A4-80 stainless steel has all the environmental resistances of A4 stainless steel, with an improved tensile strength for mechanically demanding applications.

Grade	Description	Counterpart or Close Alternative
A1	Free-machining grade of ISO 3506 stainless steel.	EN 1.4305 SAE 303
A2	Standard grade of ISO 3506 stainless steel.	EN 1.4301 SAE 304 UNS S30400 18/8 18/10
A4	Marine grade of ISO 3506 stainless steel with increased chromium and molybdenum content.	EN 1.4401/EN 1.4436 SAE 316 UNS S31600
A4-80	Hardened variant of A4 stainless steel.	-





NUTS	➤ Page - VI
WASHERS	➤ Page - IX
SOCKET SCREWS	➤ Page - XI
HEXAGONS	➤ Page - XIII
MACHINE SCREWS	➤ Page - XIV
SELF TAPPING SCREWS	➤ Page - XVI
SCREWS FOR PLASTICS	➤ Page - XVII
SECURITY SCREWS	➤ Page - XVIII
SLOTTED GRUBSCREWS	➤ Page - XIX
WOODSCREWS	➤ Page - XX
PINS	➤ Page - XXI
STUDS	➤ Page - XXII
CHIPBOARD SCREWS	➤ Page - XXIII
RETAINING RINGS	➤ Page - XXIV
SELF DRILLING	➤ Page - XXV
DRIVE BITS	➤ Page - XXVI
RIVETS	➤ Page - XXVII
KNURLED FASTENERS	➤ Page - XXVIII
ALLIED PRODUCTS	➤ Page - XXIX
PIPEPLUGS	➤ Page - XXX
SHOULDER SCREWS	➤ Page - XXXI
BUMAX	➤ Page - XXXII





[CLICK HERE TO RETURN TO THE CONTENTS PAGE](#)



+ 37 064 411 786



Inquiry@invayear.com



www.invayear.com

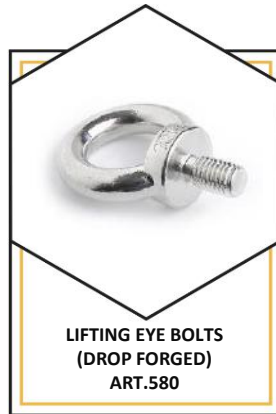
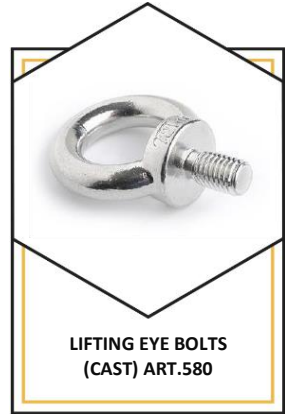
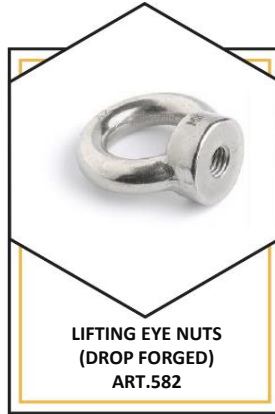
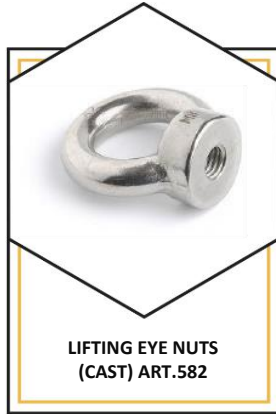

[CLICK HERE TO RETURN TO THE CONTENTS PAGE](#)



+ 37 064 411 786



Inquiry@invayear.com



www.invayear.com



[CLICK HERE TO RETURN TO THE CONTENTS PAGE](#)



+ 37 064 411 786



Inquiry@invayear.com



www.invayear.com

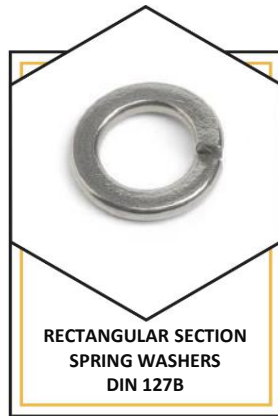
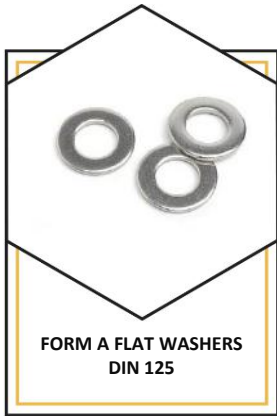

[CLICK HERE TO RETURN TO THE CONTENTS PAGE](#)



+ 37 064 411 786



Inquiry@invayear.com



www.invayear.com

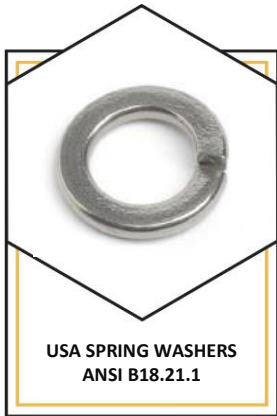
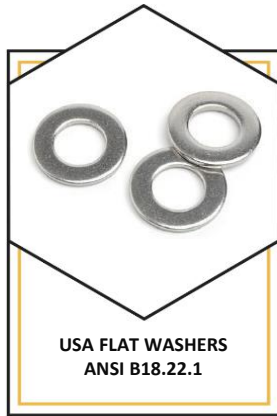
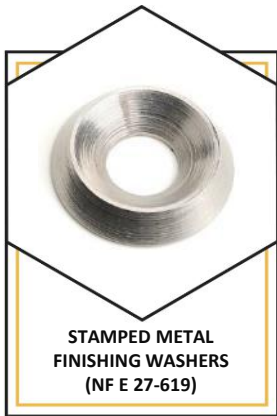

[CLICK HERE TO RETURN TO THE CONTENTS PAGE](#)



+ 37 064 411 786



Inquiry@invayear.com



www.invayear.com



**SOCKET CAP SCREWS
DIN 912**



**TX CAP SCREWS ISO
14579**



**SOCKET CAP SCREWS
WITH SERRATION
DIN 912**



**SOCKET BUTTON
SCREWS ISO 7380-1**



**TX BUTTON SCREWS ISO
7380-1**



**FLANGED SOCKET
BUTTONS ISO 7380-2**



**FLANGED TX BUTTONS
ISO 7380-2**



**LOW HEAD SOCKET CAP
SCREWS DIN 7984**



**TX LOW HEAD CAP
SCREWS ISO 14580**



**LOW HEAD SOCKET CAP
SCREWS DIN 6912**



**SOCKET COUNTERSUNK
SCREWS DIN 7991**



**SOCKET SET SCREWS
CUP POINT DIN 916**



**SOCKET SET SCREWS
FLAT POINT DIN 913**



**SOCKET SET SCREWS
CONE POINT DIN 914**



**SOCKET SET SCREWS
DOG POINT DIN 915**



**SOCKET CAP SCREWS
ANSI B18.3**



**SOCKET BUTTON
SCREWS ANSI B18.3**



**LOW HEAD SOCKET CAP
SCREWS ANSI B18.3**



**SOCKET COUNTERSUNK
SCREWS ANSI B18.3**



**SOCKET SET SCREWS
CUP POINT ANSI B18.3**

[CLICK HERE TO RETURN TO THE CONTENTS PAGE](#)



+ 37 064 411 786



Inquiry@invayear.com



www.invayear.com



[CLICK HERE TO RETURN TO THE CONTENTS PAGE](#)



+ 37 064 411 786



Inquiry@invayear.com



www.invayear.com

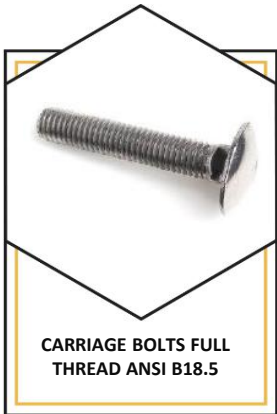
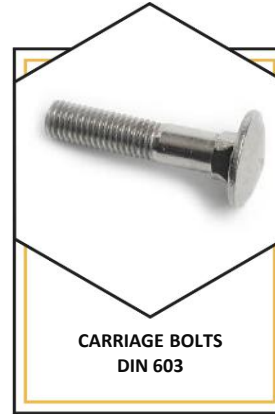

[CLICK HERE TO RETURN TO THE CONTENTS PAGE](#)



+ 37 064 411 786



Inquiry@invayear.com



www.invayear.com

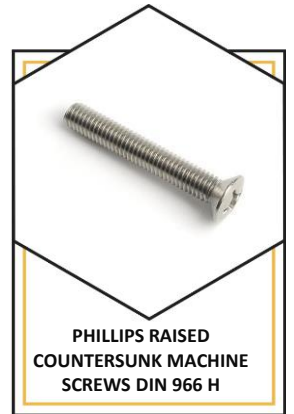

[CLICK HERE TO RETURN TO THE CONTENTS PAGE](#)



+ 37 064 411 786



Inquiry@invayear.com



www.invayear.com

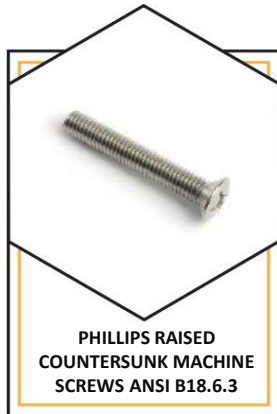
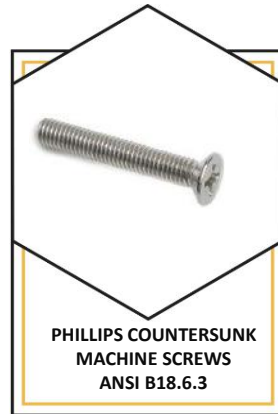
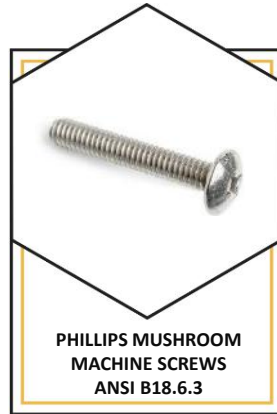
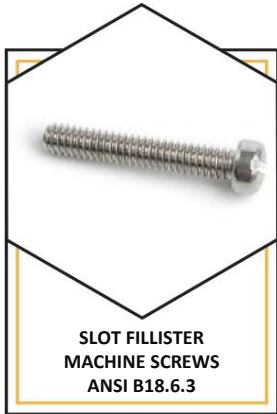
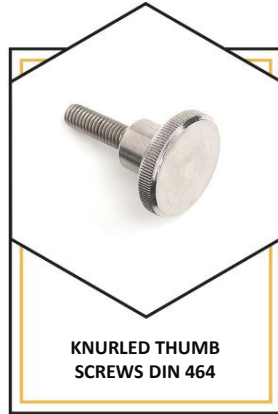

[CLICK HERE TO RETURN TO THE CONTENTS PAGE](#)



+ 37 064 411 786



Inquiry@invayear.com



www.invayear.com



[CLICK HERE TO RETURN TO THE CONTENTS PAGE](#)



+ 37 064 411 786



Inquiry@invayear.com



www.invayear.com



[CLICK HERE TO RETURN TO THE CONTENTS PAGE](#)



+ 37 064 411 786



Inquiry@invayear.com



www.invayear.com

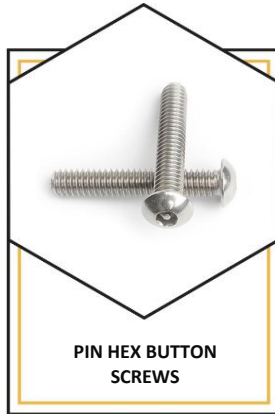
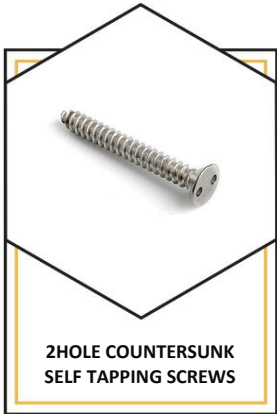
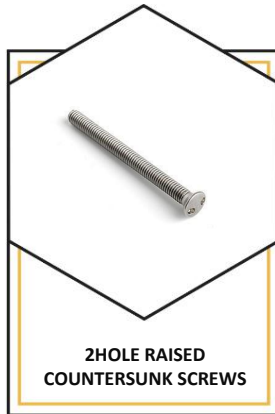
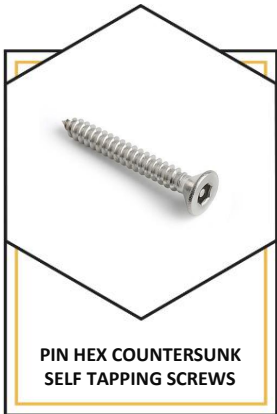
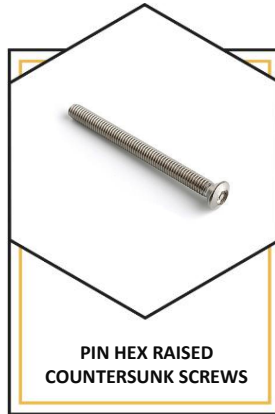
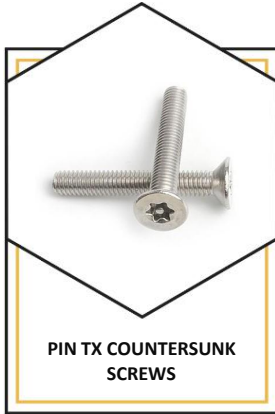
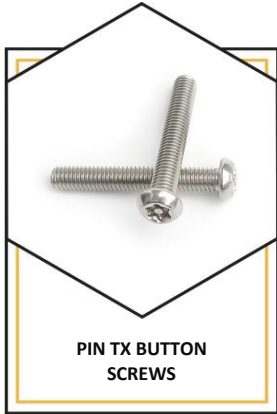

[CLICK HERE TO RETURN TO THE CONTENTS PAGE](#)



+ 37 064 411 786



Inquiry@invayear.com



www.invayear.com



[CLICK HERE TO RETURN TO THE CONTENTS PAGE](#)



+ 37 064 411 786



Inquiry@invayear.com



www.invayear.com



[CLICK HERE TO RETURN TO THE CONTENTS PAGE](#)



+ 37 064 411 786



Inquiry@invayear.com



www.invayear.com

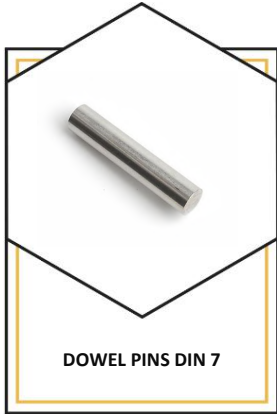

[CLICK HERE TO RETURN TO THE CONTENTS PAGE](#)



+ 37 064 411 786



Inquiry@invayear.com



www.invayear.com

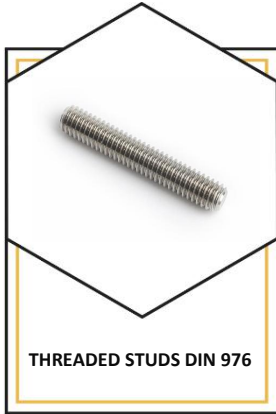
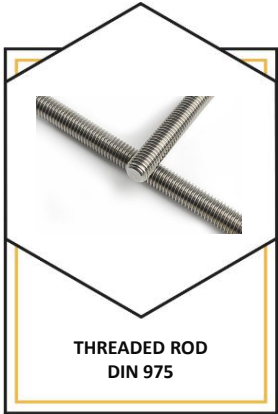

[CLICK HERE TO RETURN TO THE CONTENTS PAGE](#)



+ 37 064 411 786



Inquiry@invayear.com



www.invayear.com

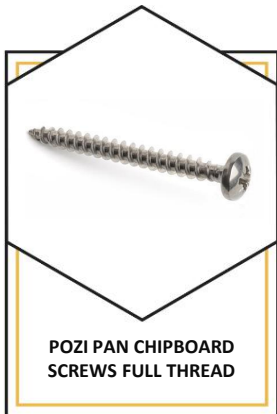

[CLICK HERE TO RETURN TO THE CONTENTS PAGE](#)



+ 37 064 411 786



Inquiry@invayear.com



www.invayear.com

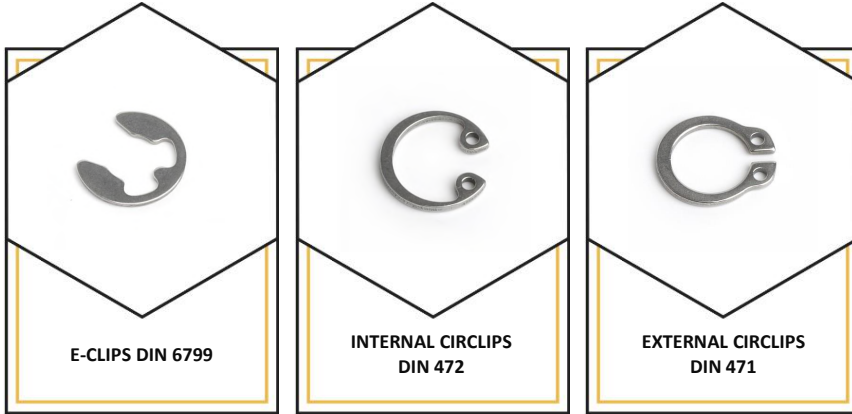

[CLICK HERE TO RETURN TO THE CONTENTS PAGE](#)



+ 37 064 411 786



Inquiry@invayear.com



www.invayear.com

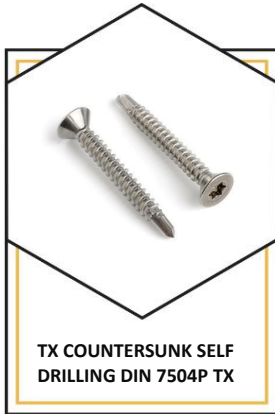
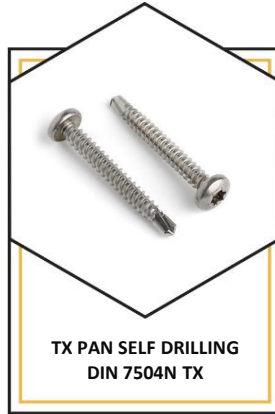

[CLICK HERE TO RETURN TO THE CONTENTS PAGE](#)



+ 37 064 411 786



Inquiry@invayear.com



www.invayear.com

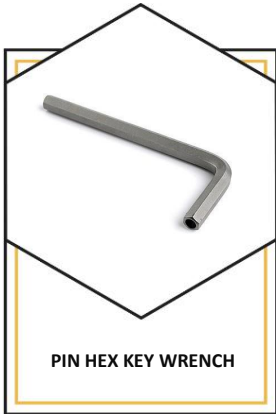
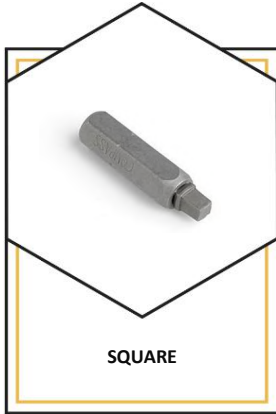
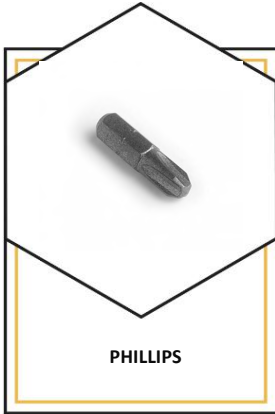
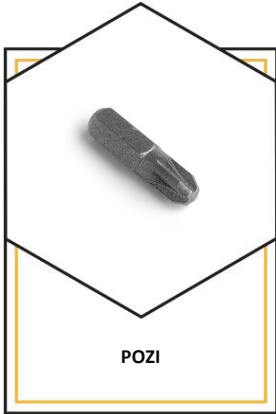

[CLICK HERE TO RETURN TO THE CONTENTS PAGE](#)



+ 37 064 411 786



Inquiry@invayear.com



www.invayear.com

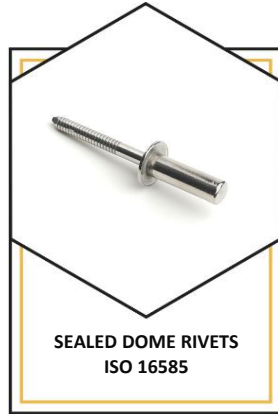

[CLICK HERE TO RETURN TO THE CONTENTS PAGE](#)



+ 37 064 411 786



Inquiry@invayear.com



www.invayear.com



**KNURLED THUMB
SCREWS DIN 464**



**KNURLED THUMB SCREWS
WITH SLOT DIN 465**



**KNURLED THUMB NUTS
HIGH TYPE DIN 466**



**KNURLED THUMB NUTS
THIN TYPE DIN 467**

[CLICK HERE TO RETURN TO THE CONTENTS PAGE](#)



+ 37 064 411 786



Inquiry@invayear.com



www.invayear.com

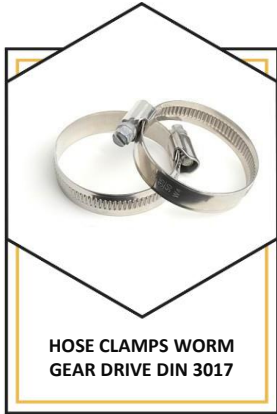

[CLICK HERE TO RETURN TO THE CONTENTS PAGE](#)



+ 37 064 411 786



Inquiry@invayear.com



www.invayear.com

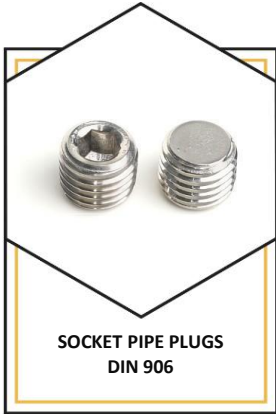

[CLICK HERE TO RETURN TO THE CONTENTS PAGE](#)



+ 37 064 411 786



Inquiry@invayear.com



www.invayear.com



[CLICK HERE TO RETURN TO THE CONTENTS PAGE](#)



+ 37 064 411 786



Inquiry@invayear.com



www.invayear.com



CLICK HERE TO RETURN TO THE CONTENTS PAGE



+ 37 064 411 786



Inquiry@invayear.com



www.invayear.com

SPECIFICATION OF PRODUCT 

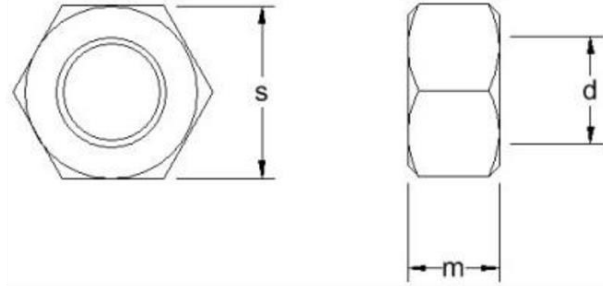

HEXAGON FULL NUTS DIN 934

Material grades: A2: ■ A4: ◆

m (Max)	0.8	1.0	1.2	1.3	1.4	1.6	1.8	2.0	2.0	2.4	2.8	3.2	4.0	5.0	5.5	6.5	8.0
Pitch	0.25	0.25	0.30	0.35	0.35	0.40	0.45	0.45	0.45	0.50	0.60	0.70	0.80	1.00	1.00	1.25	1.50
s	2.5	3.0	3.0	3.2	3.5	4.0	4.5	5.0	5.0	5.5	6.0	7.0	8.0	10	11	13	17
Length/dim	M1.0	M1.2	M1.4	M1.6	M1.7	M2	M2.3	M2.5	M2.6	M3	M3.5	M4	M5	M6	M7	M8	M10
	■	■	■◆	■◆	■◆	■◆	■◆	■◆	■◆	■◆	■◆	■◆	■◆	■◆	■◆	■◆	■◆

m (Max)	10	11	13	15	16	18	19	22	24	26	29	31	34	36	38	42	*
Pitch	1.75	2.00	2.00	2.50	2.50	2.50	3.00	3.00	3.50	3.50	4.00	4.00	4.40	4.50	5.00	5.00	*
s	19	22	24	27	30	32	36	41	46	50	55	60	65	70	75	80	*
Length/dim	M12	M14	M16	M18	M20	M22	M24	M27	M30	M33	M36	M39	M42	M45	M48	M52	M56
	■◆	■◆	■◆	■◆	■◆	■◆	■◆	■◆	■◆	■◆	■◆	■◆	■◆	■◆	■◆	■◆	■◆

[CLICK HERE TO RETURN TO THE CONTENTS PAGE](#)



+ 37 064 411 786



Inquiry@invayear.com



www.invayear.com

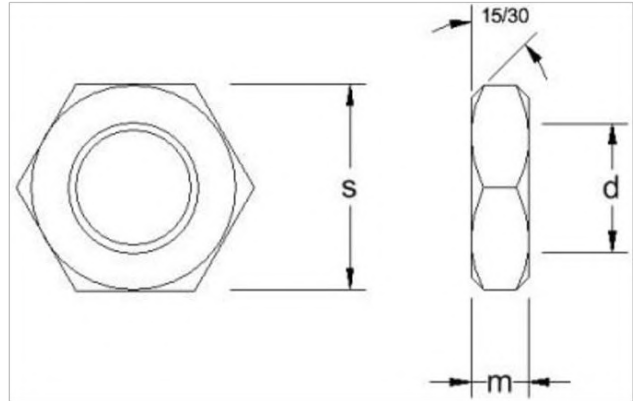

Material grades: A2: ■ A4: ◆

m (Max)	1.0	1.2	*	1.6	*	1.8	2.0	2.2	2.7	3.2	4.0	5.0	6.0	7.0	8.0	9.0	10
Pitch	0.35	0.40	*	0.45	0.45	0.50	0.60	0.70	0.80	1.00	1.25	1.50	1.75	2.00	2.00	2.50	2.50
s	3.2	4.0	*	5.0	5.0	5.5	6.0	7.0	8.0	10	13	17	19	22	24	27	30
Length/dim	M1.6	M2	M2.3	M2.5	M2.6	M3	M3.5	M4	M5	M6	M8	M10	M12	M14	M16	M18	M20
	■ ◆	■ ◆	■ ◆	■ ◆	■ ◆	■ ◆	■ ◆	■ ◆	■ ◆	■ ◆	■ ◆	■ ◆	■ ◆	■ ◆	■ ◆	■ ◆	■ ◆

m (Max)	11	12	13.5	15	16.5	18											
Pitch	2.50	3.00	3.00	3.50	3.50	4.00											
s	32	36	41	46	50	55											
Length/dim	M22	M24	M27	M30	M33	M36											
	■ ◆	■ ◆	■ ◆	■ ◆	■ ◆	■ ◆											

[CLICK HERE TO RETURN TO THE CONTENTS PAGE](#)



+ 37 064 411 786



Inquiry@invayear.com

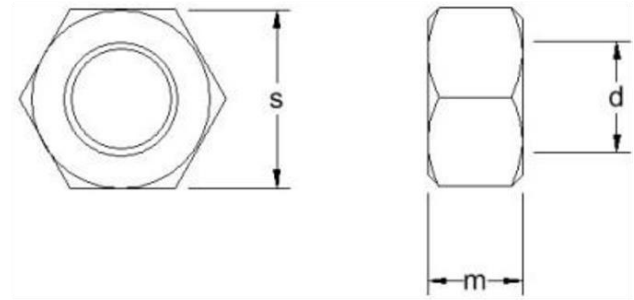

www.invayear.com

FINE THREAD HEXAGON FULL NUTS DIN 934

Material grades: A2: ■ A4: ◆

m (Max)	6.5	8.0	10	11	13	15	16	18	19	22	24	29					
s (Max)	13	17	19	22	24	27	30	32	36	41	46	55					
Length/dim	M8	M10	M12	M14	M16	M18	M20	M22	M24	M27	M30	M36					
1.0	■ ◆	■ ◆															
1.25		■ ◆	■ ◆														
1.5			■ ◆	■ ◆	■ ◆	■ ◆	■ ◆	■ ◆	■ ◆	■ ◆	■ ◆	■ ◆					
2.0							■ ◆		■ ◆	■ ◆	■ ◆						
3.0												■ ◆					

[CLICK HERE TO RETURN TO THE CONTENTS PAGE](#)

+ 37 064 411 786

Inquiry@invayear.com

www.invayear.com

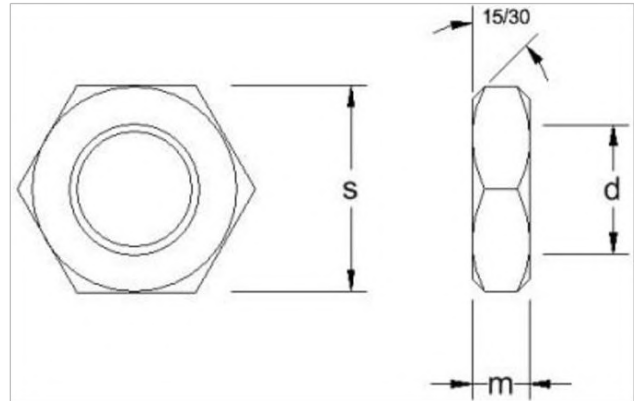
FINE THREAD HEXAGON THIN NUTS DIN 439

Material grades: A2: ■ A4: ◆

m (Max)	4.0	5.0	6.0	7.0	8.0	9.0	10	11	12	13.5	15	16.5				
s (Max)	13	17	19	22	24	27	30	34	36	41	46	50				
Length/dim	M8	M10	M12	M14	M16	M18	M20	M22	M24	M27	M30	M33				
0.75	■ ◆															
1.0	■ ◆	■ ◆	■ ◆		■ ◆											
1.25		■ ◆	■ ◆													
1.5			■ ◆	■ ◆	■ ◆	■ ◆	■ ◆	■ ◆	■ ◆	■ ◆	■ ◆	■ ◆				
2.0							■ ◆	■ ◆	■ ◆	■ ◆	■ ◆	■ ◆				

[CLICK HERE TO RETURN TO THE CONTENTS PAGE](#)



+ 37 064 411 786



Inquiry@invayear.com

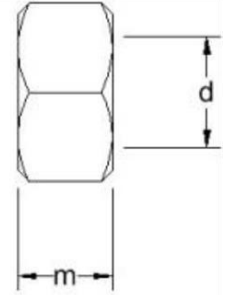
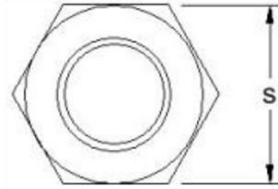

www.invayear.com

LEFT HAND THREAD HEXAGON FULL NUTS DIN 934

Material grades: A2: ■ A4: ◆

m (Max)	2.4	3.2	4.0	5.0	6.5	8.0	10	11	13	15	16	18	19	22	24		
Pitch	0.50	0.70	0.80	1.00	1.25	1.50	1.75	2.00	2.00	2.50	2.50	2.50	3.00	3.00	3.50		
s (Max)	5.5	7.0	8.0	10	13	17	19	22	24	27	30	32	36	41	46		
Length/dim	M3	M4	M5	M6	M8	M10	M12	M14	M16	M18	M20	M22	M24	M27	M30		
	■	■ ◆	■ ◆	■ ◆	■ ◆	■ ◆	■ ◆	■ ◆	■ ◆	■ ◆	■ ◆	■ ◆	■ ◆	■ ◆	■ ◆		

[CLICK HERE TO RETURN TO THE CONTENTS PAGE](#)



+ 37 064 411 786

Inquiry@invayear.com

www.invayear.com

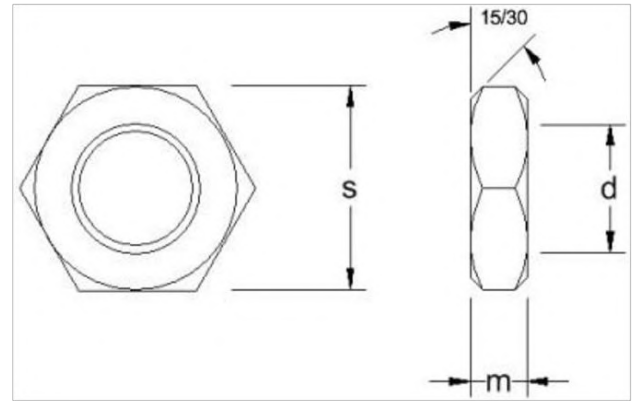

Material grades: A2: ■ A4: ◆

m (Max)	3.2	4.0	5.0	6.0	8.0	10	12	15	18									
Pitch	1.00	1.25	1.50	1.75	2.00	3.00	3.00	3.50	4.00									
s (Max)	10	13	17	19	24	30	36	46	55									
Length/dim	M6	M8	M10	M12	M16	M20	M24	M30	M36									
	■ ◆	■ ◆	■ ◆	■ ◆	■ ◆	■ ◆	■ ◆	■ ◆	■ ◆									

[CLICK HERE TO RETURN TO THE CONTENTS PAGE](#)



+ 37 064 411 786



Inquiry@invayear.com

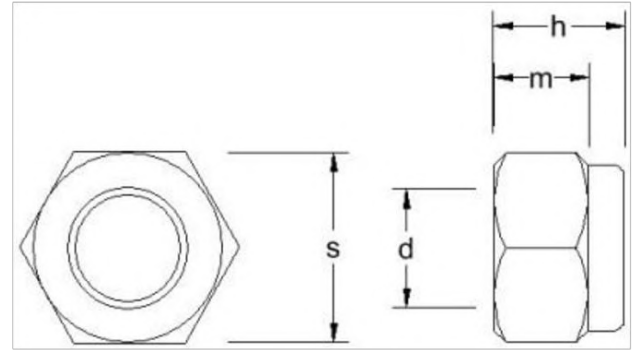

www.invayear.com

NYLON INSERT NUTS DIN 985

Material grades: A2: ■ A4: ◆

h (Max)	3.0	3.8	4.0	*	5.0	5.0	6.0	8.0	10	12	14	16	18.5	20	24	30	
m	2.0	2.0	2.4	*	2.9	3.2	4.0	5.5	6.5	8.0	9.5	10.5	13	14	15	19	
Pitch	0.40	0.45	0.50	0.60	0.70	0.80	1.00	1.25	1.50	1.75	2.00	2.00	2.50	2.50	3.00	3.50	
s	4.0	5.0	5.5	*	7.0	8.0	10	13	17	19	22	24	27	30	36	46	
Length/dim	M2	M2.5	M3	M3.5	M4	M5	M6	M8	M10	M12	M14	M16	M18	M20	M24	M30	
	■	■◆	■◆	■	■◆	■◆	■◆	■◆	■◆	■◆	■◆	■◆	■◆	■◆	■◆	■◆	

[CLICK HERE TO RETURN TO THE CONTENTS PAGE](#)



+ 37 064 411 786



Inquiry@invayear.com

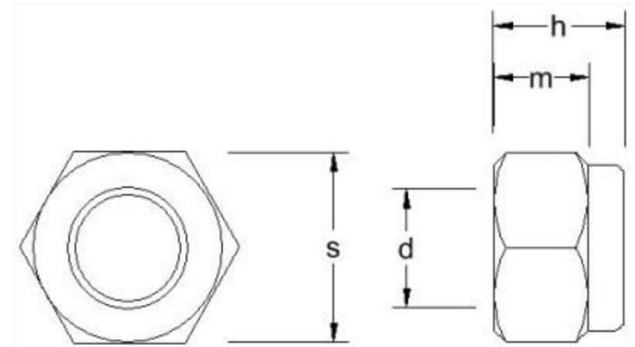

www.invayear.com

NYLON INSERT NUTS HIGH TYPE DIN 982

Material grades: A2: ■ A4: ◆

h (Max)	4.7	6.3	8.0	9.5	11.5	14	16	18	22	28										
m	3.6	4.4	4.9	6.44	8.04	10.37	12.1	14.1	16.9	20.2										
Pitch	0.70	0.80	1.00	1.25	1.50	1.75	2.00	2.00	2.50	3.00										
s	7.0	8.0	10	13	17	19	22	24	30	36										
Length/dim	M4	M5	M6	M8	M10	M12	M14	M16	M20	M24										
	■ ◆	■ ◆	■ ◆	■ ◆	■ ◆	■ ◆	■ ◆	■ ◆	■ ◆	■ ◆										

[CLICK HERE TO RETURN TO THE CONTENTS PAGE](#)



+ 37 064 411 786

Inquiry@invayear.com

www.invayear.com

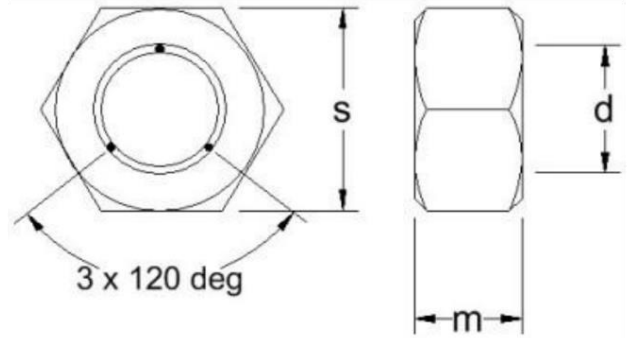
ALLMETAL SELF LOCKING NUTS ART.980

Material grades: A2: ■ A4: ◆

m (Max)	2.4	3.2	4.0	5.0	5.5	6.5	8	10	11	13	14.5	16	*	*			
Pitch	0.50	0.70	0.80	1.00	1.00	1.25	1.50	1.75	2.00	2.00	2.50	2.50	2.50	3.00			
s	5.5	7.0	8.0	10	11	13	17	19	22	24	27	30	33	36			
Length/dim	M3	M4	M5	M6	M7	M8	M10	M12	M14	M16	M18	M20	M22	M24			
	■ ◆	■ ◆	■ ◆	■ ◆	■	■ ◆	■ ◆	■ ◆	■	■ ◆	■	■ ◆	■	■			

[CLICK HERE TO RETURN TO THE CONTENTS PAGE](#)

+ 37 064 411 786

Inquiry@invayear.com

www.invayear.com

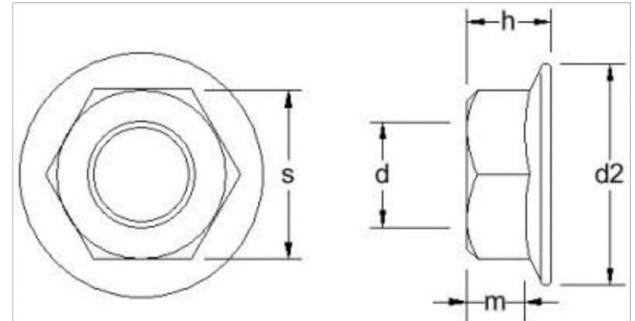
SERRATED FLANGED NUTS DIN 6923

Material grades: A2: ■ A4: ◆

d2 (Max)	*	10	11.8	14.2	17.9	21.8	26	34.5										
h (Max)	*	4.65	5.0	6.0	8.0	10	12	16										
m (Min)	*	1.9	2.2	3.1	4.5	5.5	6.7	*										
Pitch	0.50	0.70	0.80	1.00	1.25	1.50	1.75	2.00										
s (Max)	*	7.0	8.0	10	13	15	18	24										
Length/dim	M3	M4	M5	M6	M8	M10	M12	M16										
	■ ◆	■ ◆	■ ◆	■ ◆	■ ◆	■ ◆	■ ◆	■ ◆										

[CLICK HERE TO RETURN TO THE CONTENTS PAGE](#)



+ 37 064 411 786

Inquiry@invayear.com

www.invayear.com

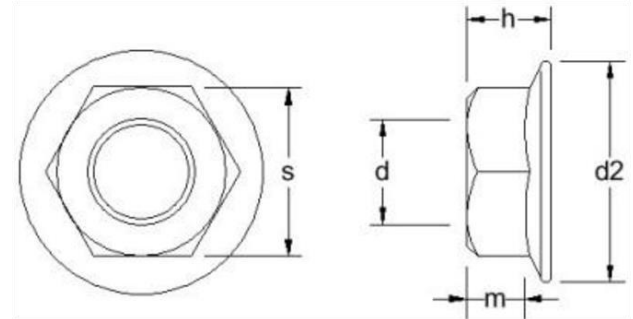
NON SERRATED FLANGED NUTS DIN 6923

Material grades: A2: ■ A4: ◆

d2 (Max)	10	11.8	14.2	17.9	21.8	26														
h (Max)	4.65	5.0	6.0	8.0	10	12														
m (Min)	1.9	2.2	3.1	4.5	5.5	6.7														
Pitch	0.70	0.80	1.00	1.25	1.50	1.75														
s (Max)	7.0	8.0	10	13	15	18														
Length/dim	M4	M5	M6	M8	M10	M12														
	■ ◆	■ ◆	■ ◆	■ ◆	■ ◆	■ ◆														

[CLICK HERE TO RETURN TO THE CONTENTS PAGE](#)

+ 37 064 411 786

Inquiry@invayear.com

www.invayear.com

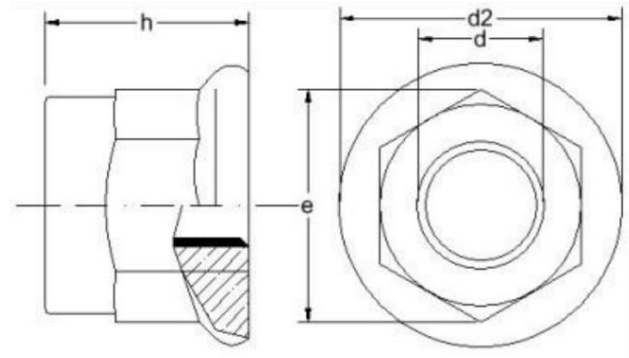

Material grades: A2: ■ A4: ◆

Drive	SW6	SW7	SW8	SW10	SW13	SW15	SW18											
d2 (Max)	7.8	10	11.8	14.2	17.9	21.8	26											
e	6.33	7.66	8.79	11.05	14.38	16.64	20.03											
h (Max)	*	*	7.1	9.1	11.1	13.5	16.1											
Pitch	0.50	0.70	0.80	1.00	1.25	1.50	1.75											
Length/dim	M3	M4	M5	M6	M8	M10	M12											
	■ ◆	■ ◆	■ ◆	■ ◆	■ ◆	■ ◆	■ ◆											

CLICK HERE TO RETURN TO THE CONTENTS PAGE



+ 37 064 411 786



Inquiry@invayear.com

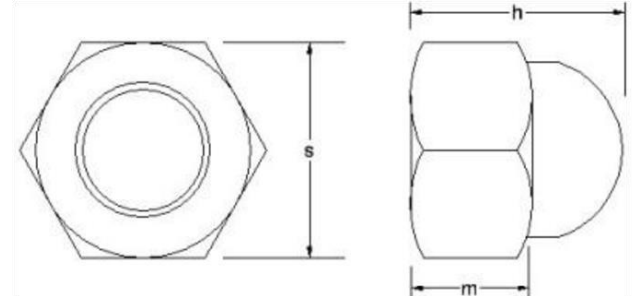

www.invayear.com

HEXAGON DOMED NUTS DIN 1587

Material grades: A2: ■ A4: ◆

h (Max)	6	8	10	12	*	15	18	22	25	28	32	34	39	42	47	52	
m (Max)	2.4	3.2	4.0	5.0	*	6.5	8.0	10	11	13	15	16	18	19	22	24	
Pitch	0.50	0.70	0.80	1.00	1.00	1.25	1.5	1.75	2.0	2.0	2.50	2.5	2.5	3.0	3.0	3.5	
s	5.5	7.0	8.0	10	*	13	17	19	22	24	27	30	32	36	41	46	
Length/dim	M3	M4	M5	M6	M7	M8	M10	M12	M14	M16	M18	M20	M22	M24	M27	M30	
	■ ◆	■ ◆	■ ◆	■ ◆	■	■ ◆	■ ◆	■ ◆	■ ◆	■ ◆	■ ◆	■ ◆	■ ◆	■ ◆	■ ◆	■ ◆	

[CLICK HERE TO RETURN TO THE CONTENTS PAGE](#)



+ 37 064 411 786

Inquiry@invayear.com

www.invayear.com

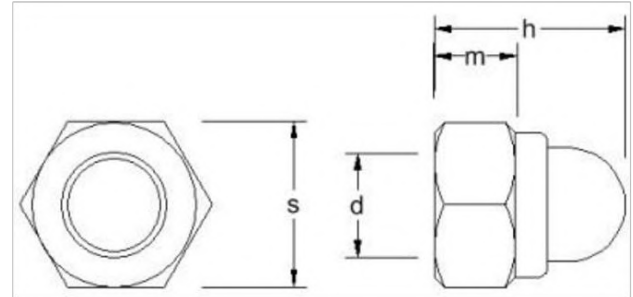
 Material grades: A2: ■

h	9.6	10.5	12	14	18.1	22.5	27.5												
m	*	4.4	4.9	6.44	8.04	10.37	*												
Pitch	0.70	0.80	1.00	1.25	1.50	1.75	2.00												
s	7.0	8.0	10	13	17	19	24												
Length/dim	M4	M5	M6	M8	M10	M12	M16												
	■	■	■	■	■	■	■												

[CLICK HERE TO RETURN TO THE CONTENTS PAGE](#)



+ 37 064 411 786



Inquiry@invayear.com

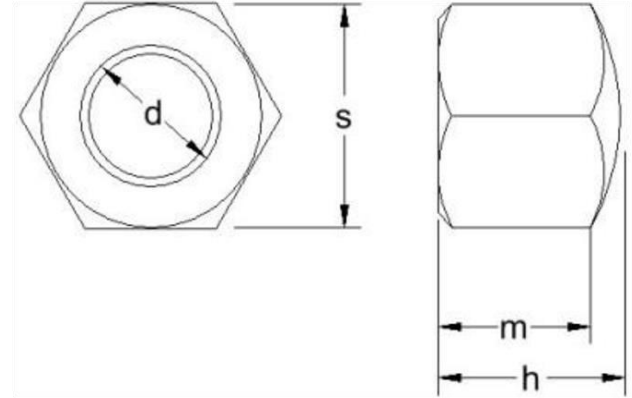

www.invayear.com

HEXAGON CAP NUTS DIN 917

Material grades: A2: ■ A4: ◆

h	4.5	5.5	7	9	12	14	16	18	20	22	25	28	30	32	34		
m	4.0	4.4	5.2	7	9.5	11	13.6	15	17	19	21	22	24	26	28		
Pitch	0.50	0.70	0.80	1.00	1.25	1.50	1.75	2.00	2.00	2.50	2.50	2.50	3.00	2.5	3.0		
s	5.5	7.0	8.0	10	13	17	19	22	24	27	30	32	36	41	46		
Length/dim	M3	M4	M5	M6	M8	M10	M12	M14	M16	M18	M20	M22	M24	M27	M30		
	■ ◆	■ ◆	■ ◆	■ ◆	■ ◆	■ ◆	■ ◆	■ ◆	■ ◆	■ ◆	■ ◆	■ ◆	■ ◆	■ ◆	■ ◆		

[CLICK HERE TO RETURN TO THE CONTENTS PAGE](#)



+ 37 064 411 786

Inquiry@invayear.com

www.invayear.com

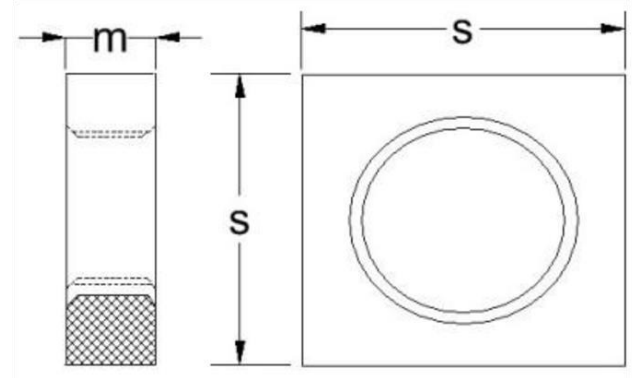

Material grades: A2: ■ A4: ◆

m	1.2	1.6	1.8	2.2	2.7	3.2	4	5									
Pitch	0.40	0.45	0.50	0.70	0.80	1.00	1.25	1.50									
s	4.0	5.0	5.5	7.0	8.0	10	13	17									
Length/dim	M2	M2.5	M3	M4	M5	M6	M8	M10									
	■	■◆	■◆	■◆	■◆	■◆	■◆	■◆									

[CLICK HERE TO RETURN TO THE CONTENTS PAGE](#)



+ 37 064 411 786



Inquiry@invayear.com

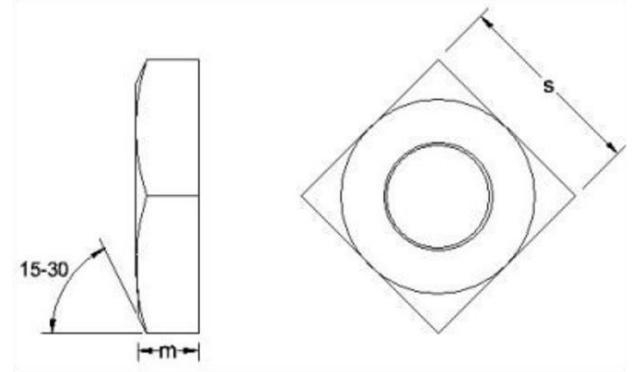

www.invayear.com

CHAMFERED SQUARE NUTS DIN 557

Material grades: A2: ■ A4: ◆

m	4.0	5.0	6.5	8.0	10	13													
Pitch	0.80	1.00	1.25	1.50	1.75	2.00													
s	8.0	10	13	17	19	24													
Length/dim	M5	M6	M8	M10	M12	M16													
	■ ◆	■ ◆	■ ◆	■ ◆	■ ◆	■ ◆													

[CLICK HERE TO RETURN TO THE CONTENTS PAGE](#)



+ 37 064 411 786

Inquiry@invayear.com

www.invayear.com

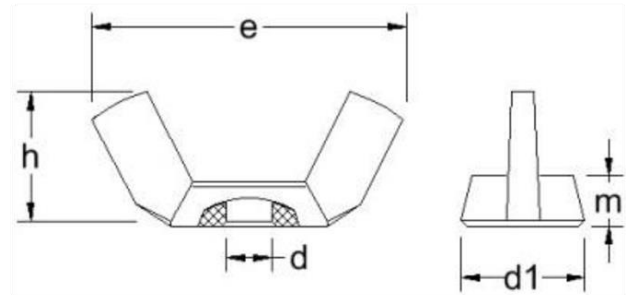

Material grades: A2: ■ A4: ◆

dI	8.0	8.0	10.3	12.7	13.8	16.5	22.5	26.0	26.6	29.3	29.3						
e	17.6	17.6	22.5	27.8	30.3	36.2	49.4	52.7	58.3	66.5	66.5						
h	8.6	8.6	11	13.6	14.8	17.3	22.3	30.8	30.8	31.2	31.2						
m	2.9	2.9	4.1	5.1	5.6	6.8	9.0	10.0	10.7	12.2	12.2						
Pitch	0.50	0.70	0.80	1.00	1.25	1.50	1.75	2.00	2.00	2.50	2.50						
Length/dim	M3	M4	M5	M6	M8	M10	M12	M14	M16	M18	M20						
	■ ◆	■ ◆	■ ◆	■ ◆	■ ◆	■ ◆	■ ◆	■ ◆	■ ◆	■ ◆	■ ◆						

[CLICK HERE TO RETURN TO THE CONTENTS PAGE](#)



+ 37 064 411 786

Inquiry@invayear.com

www.invayear.com

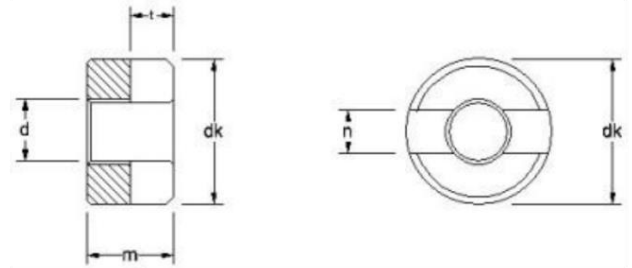
SLOTTED ROUND NUTS DIN 546

Material grades: A2: ■ A4: ◆

dk	4.5	5.5	6.0	8.0	9.0	11.0	14.0	18.0	21.0	26.0								
m	2.0	2.2	2.5	3.5	4.2	5.0	6.5	8.0	10.0	12.0								
n	1.0	1.2	1.2	1.4	2.0	2.5	3.0	3.5	4.0	4.0								
Pitch	0.40	0.45	0.50	0.70	0.80	1.00	1.25	1.50	1.75	2.00								
τ (Min)	0.8	0.9	1.0	1.2	1.5	2.0	2.5	3.2	3.8	3.8								
Length/dim	M2	M2.5	M3	M4	M5	M6	M8	M10	M12	M16								
	■ ◆	■ ◆	■ ◆	■ ◆	■ ◆	■ ◆	■ ◆	■ ◆	◆	◆								

[CLICK HERE TO RETURN TO THE CONTENTS PAGE](#)



+ 37 064 411 786



Inquiry@invayear.com

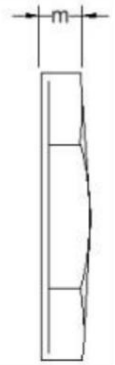
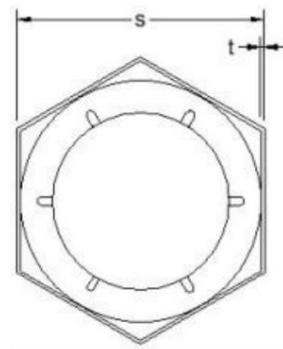

www.invayear.com

SELF LOCKING COUNTER (PAL) NUTS DIN 7967

Material grades: A2: ■ A4: ◆

m	2.5	2.5	3.0	3.5	4.0	4.5	5.0	6.0	7.0	7.0									
Pitch	0.70	0.80	1.00	1.25	1.50	1.75	2.00	2.50	3.00	3.00									
s	7.0	8.0	10	13	17	19	24	30	36	41									
t	0.3	0.4	0.4	0.5	0.5	0.6	0.7	0.8	0.9	1.0									
Length/dim	M4	M5	M6	M8	M10	M12	M16	M20	M24	M27									
	■ ◆	■ ◆	■ ◆	■ ◆	■ ◆	■ ◆	■ ◆	■ ◆	■ ◆	■ ◆									

[CLICK HERE TO RETURN TO THE CONTENTS PAGE](#)



+ 37 064 411 786



Inquiry@invayear.com

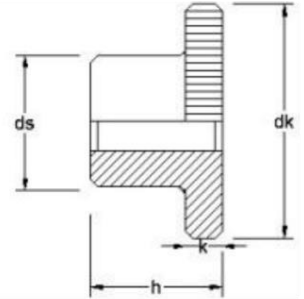
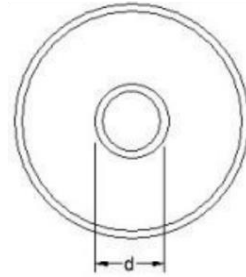

www.invayear.com

KNURLED THUMB NUTS HIGH TYPE DIN 466

Material grades: A2: ■

dk	9	11	12	16	20	24	30	36											
ds	4.5	5	6	8	10	12	16	20											
h	5.3	6.5	7.5	9.5	11.5	15.0	18.0	23.0											
k	2.0	2.5	2.5	3.5	4.0	5.0	6.0	8.0											
Pitch	0.40	0.45	0.50	0.70	0.80	1.00	1.25	1.50											
Length/dim	M2	M2.5	M3	M4	M5	M6	M8	M10											
	■	■	■	■	■	■	■	■											

[CLICK HERE TO RETURN TO THE CONTENTS PAGE](#)



+ 37 064 411 786

Inquiry@invayear.com

www.invayear.com

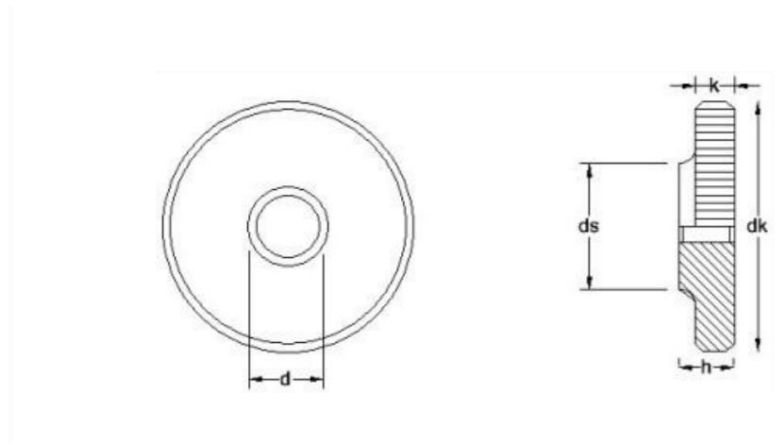
 Material grades: **A2:** ■

dk	11	12	16	20	24	30	36										
ds	5	6	8	10	12	16	20										
h	3	3	4	5	6	8	10										
k	2.5	2.5	3.5	4.0	5.0	6.0	8.0										
Pitch	0.45	0.50	0.70	0.80	1.00	1.25	1.50										
Length/dim	M2.5	M3	M4	M5	M6	M8	M10										
	■	■	■	■	■	■	■										

CLICK HERE TO RETURN TO THE CONTENTS PAGE



+ 37 064 411 786

Inquiry@invayear.com

www.invayear.com

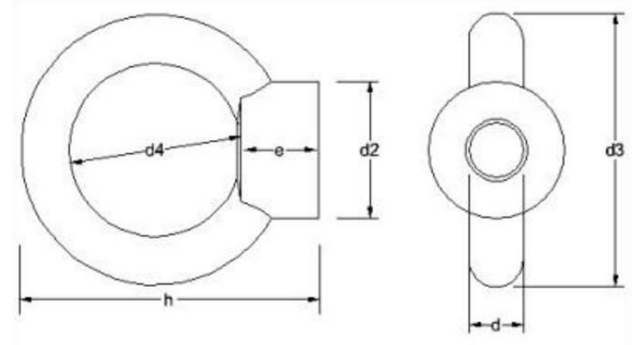
LIFTING EYE NUTS (CAST) ART.582

Material grades: A2: ■ A4: ◆

d2	16	20	25	30	35	40	50	65	65	75										
d3	27	36	45	54	63	72	90	108	108	126										
d4	16	20	25	30	35	40	50	60	60	70										
e	8.0	8.5	10.0	11.0	13.0	16.0	20.0	22.0	25.0	30.0										
h	31	36	45	53	62	71	90	109	109	128										
Pitch	1.00	1.25	1.50	1.75	2.00	2.50	3.00	3.00	3.50	4.00										
Length/dim	M6	M8	M10	M12	M16	M20	M24	M27	M30	M36										
	■ ◆	■ ◆	■ ◆	■ ◆	■ ◆	■ ◆	■ ◆	■ ◆	■ ◆	■ ◆										

[CLICK HERE TO RETURN TO THE CONTENTS PAGE](#)



+ 37 064 411 786



Inquiry@invayear.com



www.invayear.com

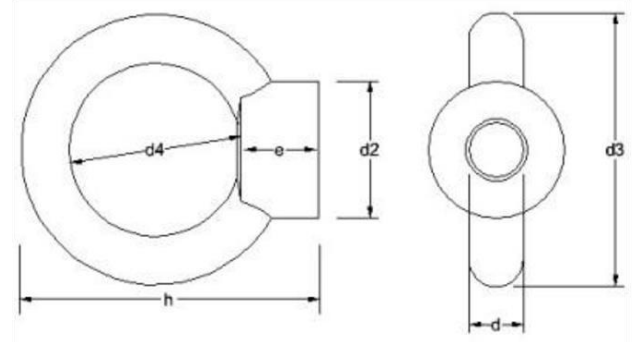

Material grades: A2: ■ A4: ◆

d2	16	20	25	30	35	40	50	65	65	75										
d3	27	36	45	54	63	72	90	108	108	126										
d4	16	20	25	30	35	40	50	60	60	70										
e	8.0	8.5	10.0	11.0	13.0	16.0	20.0	22.0	25.0	30.0										
h	31	36	45	53	62	71	90	109	109	128										
Pitch	1.00	1.25	1.50	1.75	2.00	2.50	3.00	3.00	3.50	4.00										
Length/dim	M6	M8	M10	M12	M16	M20	M24	M27	M30	M36										
	■ ◆	■ ◆	■ ◆	■ ◆	■ ◆	■ ◆	■ ◆	■ ◆	■ ◆	■ ◆										

[CLICK HERE TO RETURN TO THE CONTENTS PAGE](#)



+ 37 064 411 786



Inquiry@invayear.com

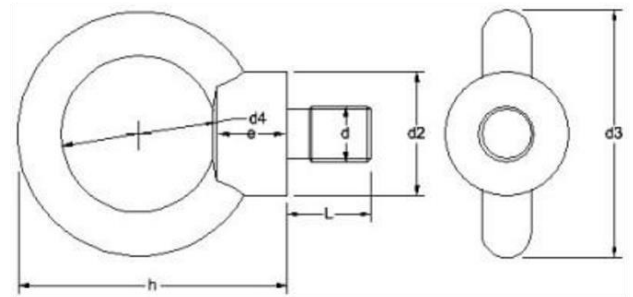

www.invayear.com

LIFTING EYE BOLTS (CAST) ART.580

Material grades: A2: ■ A4: ◆

d2	16	20	25	30	35	40	50	65	65	75										
d3	27	36	45	54	63	72	90	108	108	126										
d4	16	20	25	30	35	40	50	60	60	70										
e	6	6	8	10	12	14	18	22	22	26										
h	31	36	45	53	62	71	90	109	109	128										
L	11.0	13.0	17.0	20.5	27.0	30.0	36.0	45.0	45.0	54.0										
Pitch	1.00	1.25	1.50	1.75	2.00	2.50	3.00	3.00	3.50	4.00										
Length/dim	M6	M8	M10	M12	M16	M20	M24	M27	M30	M36										
	■ ◆	■ ◆	■ ◆	■ ◆	■ ◆	■ ◆	■ ◆	■ ◆	■ ◆	■ ◆										

CLICK HERE TO RETURN TO THE CONTENTS PAGE



+ 37 064 411 786



Inquiry@invayear.com



www.invayear.com

ANSI B18.6.3

HEXAGON FULL NUTS ANSI B18.6.3

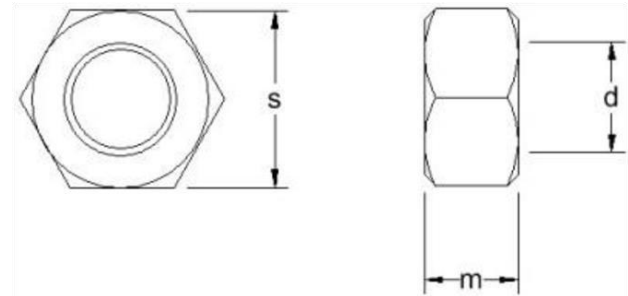

Material grades: A2: ■ A4: ◆

m (Max)	0.050	0.050	0.050	0.066	0.066	0.066	0.066	0.098	0.098	0.114	0.114	0.114	0.114	0.130	0.130	0.130	0.130
s (Max)	0.156	0.156	0.156	0.188	0.188	0.188	0.188	0.250	0.250	0.312	0.312	0.312	0.312	0.344	0.344	0.375	0.375
Length/dim	0-80	1-64	1-72	2-56	2-64	3-48	3-56	4-40	4-48	5-40	5-44	6-32	6-40	8-32	8-36	10-24	10-32
	■	■	■	■	■	■	■	■◆	■	■◆	■	■◆	■	■◆	■	■◆	■◆

m (Max)	0.161	0.161	0.226	0.226	0.273	0.273	0.337	0.337	0.385	0.385	0.448	0.448	0.496	0.496	0.559	0.559	0.665
s (Max)	0.438	0.438	0.438	0.438	0.500	0.500	0.562	0.562	0.688	0.688	0.750	0.750	0.875	0.875	0.938	0.938	1.125
Length/dim	12-24	12-28	1/4-20	1/4-28	5/16-18	5/16-24	3/8-16	3/8-24	7/16-14	7/16-20	1/2-13	1/2-20	9/16-12	9/16-18	5/8-11	5/8-18	3/4-10
	■◆	■	■◆	■◆	■◆	■◆	■◆	■◆	■◆	■◆	■◆	■◆	■◆	■◆	■◆	■◆	■◆

m (Max)	0.665	0.776	0.776	0.887	0.887	0.999	0.999	1.094	1.094	1.206	1.206	1.317	1.317	1.500	1.500	1.718	1.718
s (Max)	1.125	1.312	1.312	1.500	1.500	1.688	1.688	1.875	1.875	2.062	2.062	2.250	2.250	2.625	2.625	3.000	3.000
Length/dim	3/4-16	7/8-9	7/8-14	1-8	1-12	1.1/8-7	1.1/8-12	1.1/4-7	1.1/4-12	1.3/8-6	1.3/8-12	1.1/2-6	1.1/2-12	1.3/4-5	1.3/4-8	2-4.1/2	2-8
	■◆	■◆	■◆	■◆	■◆	■◆	■◆	■◆	■◆	■◆	■◆	■◆	■◆	■◆	■◆	■◆	■◆

[CLICK HERE TO RETURN TO THE CONTENTS PAGE](#)



+ 37 064 411 786



Inquiry@invayear.com

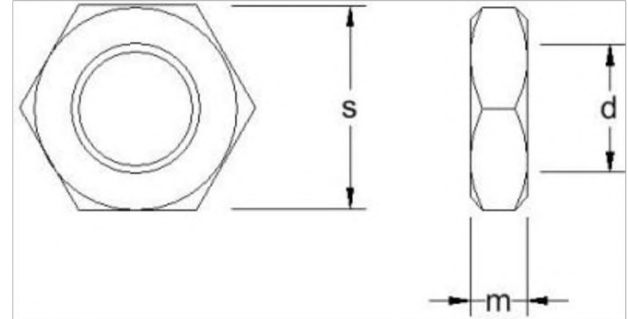

www.invayear.com

HEXAGON THIN NUTS ANSI B18.2.2

Material grades: A2: ■ A4: ◆

m (Max)	0.163	0.163	0.195	0.195	0.227	0.227	0.260	0.260	0.323	0.323	0.324	0.324	0.387	0.387	0.446	0.446	0.510
s (Max)	0.438	0.438	0.500	0.500	0.562	0.562	0.688	0.688	0.750	0.750	0.875	0.875	0.938	0.938	1.125	1.125	1.312
Length/dim	1/4-20	1/4-28	5/16-18	5/16-24	3/8-16	3/8-24	7/16-14	7/16-20	1/2-13	1/2-20	9/16-12	9/16-18	5/8-11	5/8-18	3/4-10	3/4-16	7/8-9
	■ ◆	■ ◆	■ ◆	■ ◆	■ ◆	■ ◆	■ ◆	■ ◆	■ ◆	■ ◆	■ ◆	■ ◆	■ ◆	■ ◆	■ ◆	■ ◆	■ ◆

[CLICK HERE TO RETURN TO THE CONTENTS PAGE](#)



+ 37 064 411 786



Inquiry@invayear.com

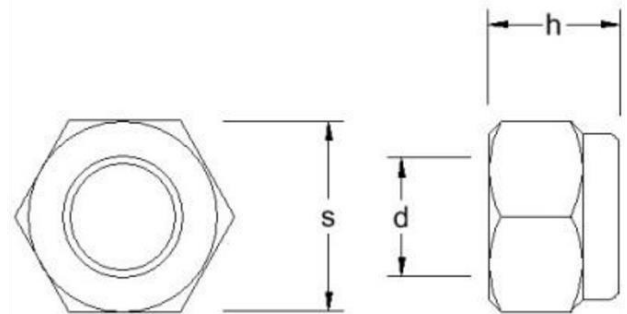

www.invayear.com

NUTS
NYLON INSERT NUTS

Material grades: A2: ■ A4: ◆

h(Max)	0.141	0.141	0.141	0.172	0.234	0.234	0.234	0.313	0.313	0.313	0.344	0.344	0.453	0.453	0.453	0.453	0.594
s (Max)	0.250	0.250	0.250	0.312	0.344	0.375	0.375	0.438	0.438	0.438	0.500	0.500	0.562	0.562	0.688	0.688	0.750
Length/dim	2-56	4-40	5-40	6-32	8-32	10-24	10-32	12-24	1/4-20	1/4-28	5/16-18	5/16-24	3/8-16	3/8-24	7/16-14	7/16-20	1/2-13
	■	■	■	■◆	■◆	■◆	■◆	■	■◆	■◆	■◆	■◆	■◆	■◆	■◆	■◆	■◆
h(Max)	0.594	0.640	0.640	0.750	0.750	0.875	0.875	0.984	0.984	1.047	1.047						
s (Max)	0.750	0.875	0.875	0.938	0.938	1.063	1.063	1.250	1.250	1.440	1.440						
Length/dim	1/2-20	9/16-12	9/16-18	5/8-11	5/8-18	3/4-10	3/4-16	7/8-9	7/8-14	1-8	1-12						
	■◆	■◆	■	■◆	■◆	■◆	■◆	■◆	■	■◆	◆						

[CLICK HERE TO RETURN TO THE CONTENTS PAGE](#)



+ 37 064 411 786



Inquiry@invayear.com

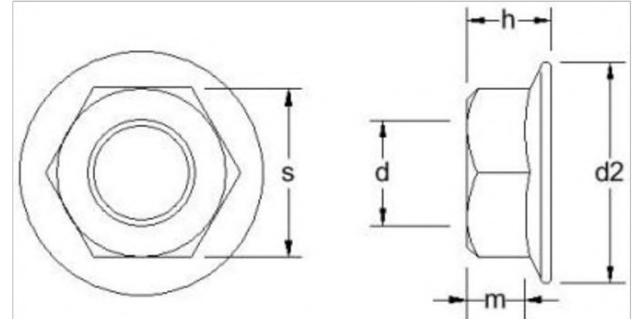

www.invayear.com

SERRATED FLANGED NUTS

Material grades: A2: ■ A4: ◆

d2 (Max)	0.422	0.469	0.500	0.500	0.594	0.594	0.594	0.680	0.680	0.750	0.750	1.031	1.031				
h (Max)	0.171	0.203	0.219	0.219	0.236	0.236	0.236	0.283	0.283	0.347	0.347	0.458	0.458				
m (Min)	0.10	0.13	0.13	0.13	0.14	0.14	0.14	0.17	0.17	0.23	0.23	0.31	0.31				
s (Max)	0.312	0.344	0.375	0.375	0.438	0.438	0.438	0.500	0.500	0.562	0.562	0.750	0.750				
Length/dim	6-32	8-32	10-24	10-32	12-24	1/4-20	1/4-28	5/16-18	5/16-24	3/8-16	3/8-24	1/2-13	1/2-20				
	■◆	■◆	■◆	■◆	■	■◆	■	■◆	■	■◆	■	■◆	■				

[CLICK HERE TO RETURN TO THE CONTENTS PAGE](#)



+ 37 064 411 786



Inquiry@invayear.com

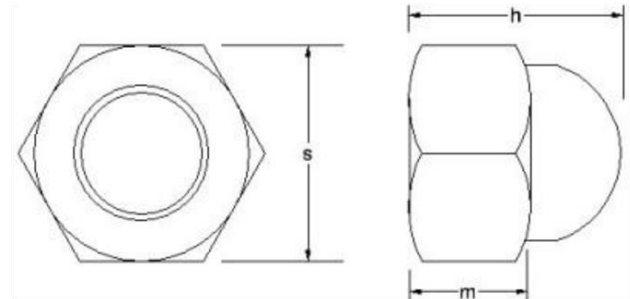

www.invayear.com

NUTS
HEXAGON DOMED NUTS

Material grades: A2: ■ A4: ◆

h	0.250	*	0.296	0.312	0.390	0.390	0.421	0.468	0.468	0.531	0.531	0.625	0.625	0.718	0.718	0.812	0.812
m	*	*	0.171	0.171	0.203	0.203	0.203	0.234	0.234	0.281	0.281	0.312	0.312	0.343	0.343	0.421	0.421
s (Max)	0.250	*	0.312	0.312	0.375	0.375	0.375	0.437	0.437	0.562	0.562	0.625	0.625	0.625	0.625	0.750	0.750
Length/dim	4-40	5-40	6-32	8-32	10-24	10-32	12-24	1/4-20	1/4-28	5/16-18	5/16-24	3/8-16	3/8-24	7/16-14	7/16-20	1/2-13	1/2-20
	■ ◆	■ ◆	■ ◆	■ ◆	■ ◆	■ ◆	■	■ ◆	■ ◆	■ ◆	■ ◆	■ ◆	■ ◆	■	■	■ ◆	■ ◆

h	0.984	1.187															
m	0.531	0.593															
s (Max)	1.000	1.062															
Length/dim	5/8-11	3/4-10															
	■ ◆	■ ◆															

[CLICK HERE TO RETURN TO THE CONTENTS PAGE](#)



+ 37 064 411 786



Inquiry@invayear.com

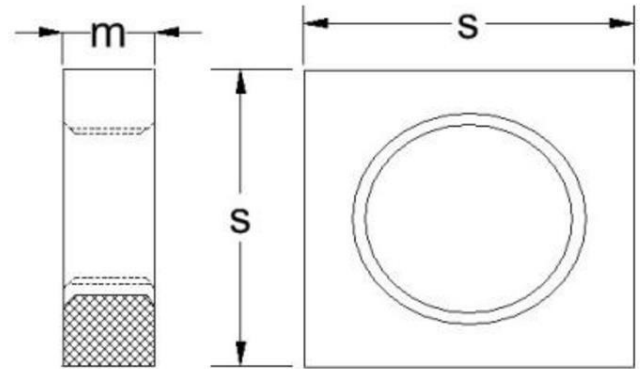

www.invayear.com

SQUARE NUTS ANSI B18.2.2

Material grades: A2: ■ A4: ◆

m (Max)	0.098	0.114	0.130	0.130	0.130	0.235	0.283	0.346	0.394	0.458	0.569	0.680						
s (Max)	0.250	0.312	0.344	0.375	0.375	0.438	0.562	0.625	0.750	0.812	1.000	1.125						
Length/dim	4-40	6-32	8-32	10-24	10-32	1/4-20	5/16-18	3/8-16	7/16-14	1/2-13	5/8-11	3/4-10						
	■◆	■◆	■◆	■◆	■◆	■◆	■◆	■◆	◆	■◆	■	■						

[CLICK HERE TO RETURN TO THE CONTENTS PAGE](#)



+ 37 064 411 786

Inquiry@invayear.com

www.invayear.com

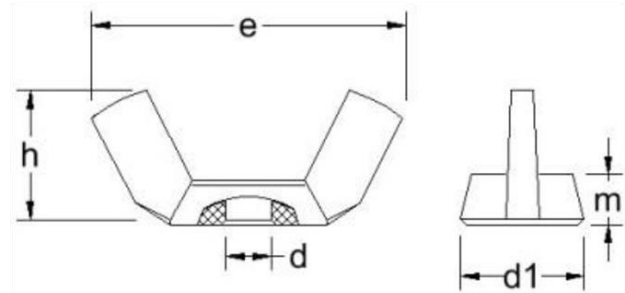
NUTS
WING NUTS

Material grades: A2: ■ A4: ◆

dI (Max)	0.33	0.43	0.43	0.43	0.50	0.50	0.50	0.58	0.58	0.70	0.70	0.93	0.93	0.93	1.19	1.19
e (Max)	0.720	0.910	0.910	0.910	1.10	1.100	1.100	1.250	1.250	1.440	1.440	1.94	1.940	1.940	2.760	2.760
h (Max)	0.410	0.470	0.470	0.470	0.570	0.570	0.570	0.660	0.660	0.790	0.790	1.00	1.00	1.00	1.44	1.44
m (Max)	0.14	0.18	0.18	0.18	0.22	0.22	0.22	0.25	0.25	0.30	0.30	0.39	0.39	0.39	0.55	0.55
Length/dim	6-32	8-32	10-24	10-32	12-24	1/4-20	1/4-28	5/16-18	5/16-24	3/8-16	3/8-24	7/16-14	1/2-13	1/2-20	5/8-11	3/4-10
	■◆	■◆	■◆	■◆	■◆	■◆	■◆	■◆	■◆	■◆	■◆	■◆	■◆	■◆	■◆	■◆

CLICK HERE TO RETURN TO THE CONTENTS PAGE



+ 37 064 411 786



Inquiry@invayear.com

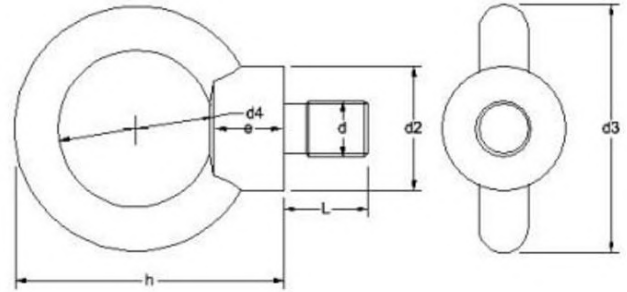

www.invayear.com

LIFTING EYE BOLTS (DROP FORGED) ART.580

Material grades: A2: ■ A4: ◆

d2	16	20	25	30	35	40	50	65	65	75										
d3	27	36	45	54	63	72	90	108	108	126										
d4	16	20	25	30	35	40	50	60	60	70										
e	6	6	8	10	12	14	18	22	22	26										
h	31	36	45	53	62	71	90	109	109	128										
L	11.0	13.0	17.0	20.5	27.0	30.0	36.0	45.0	45.0	54.0										
Pitch	1.00	1.25	1.50	1.75	2.00	2.50	3.00	3.00	3.50	4.00										
Length/dim	M6	M8	M10	M12	M16	M20	M24	M27	M30	M36										
	■ ◆	■ ◆	■ ◆	■ ◆	■ ◆	■ ◆	■ ◆	■ ◆	■ ◆	■ ◆										

[CLICK HERE TO RETURN TO THE CONTENTS PAGE](#)



+ 37 064 411 786

Inquiry@invayear.com

www.invayear.com

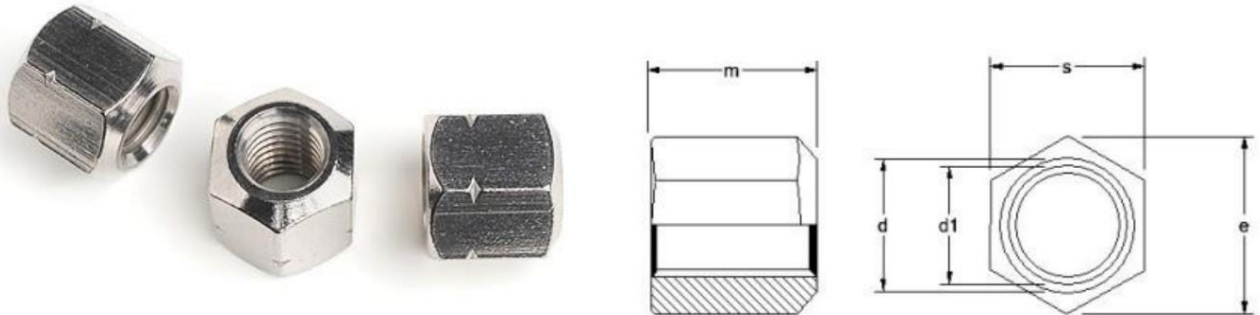

Material grades: A2: ■ A4: ◆

d1	7.0	9.0	11.5	14.0	16.0	18.0	22.0	26.0	29.0	32.0	35.0	38.0						
e	11.05	14.38	17.77	20.03	25.30	26.75	33.53	39.98	46.55	51.28	57.50	61.31						
m	9	12	15	18	21.5	24	30	36	40.5	45	49.5	54						
Pitch	1.00	1.25	1.50	1.75	2.00	2.00	2.50	3.00	3.00	3.50	3.50	4.00						
s	10	13	16	18	22	24	30	36	41	46	50	55						
Length/dim	M6	M8	M10	M12	M14	M16	M20	M24	M27	M30	M33	M36						
9	■ ◆																	
12		■ ◆																
15			■ ◆															
18				■ ◆														
22					■ ◆													
24						■ ◆												
30							■ ◆											
36								■ ◆										
41									■ ◆									
45										■ ◆								
50											■ ◆							
54												■ ◆						

[CLICK HERE TO RETURN TO THE CONTENTS PAGE](#)



+ 37 064 411 786



Inquiry@invayear.com

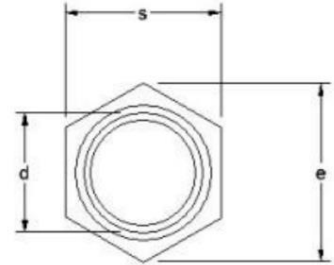
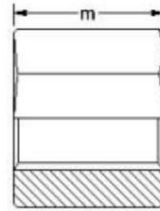

www.invayear.com

STUDDING CONNECTOR NUTS DIN 6334

Material grades: A2: ■ A4: ◆

e	9.0	11.1	15.0	19.6	21.9	25.5	27.7	34.6	41.6	53.1									
m	15	18	24	30	36	42	48	60	72	90									
Pitch	0.80	1.00	1.25	1.50	1.75	2.00	2.00	2.50	3.00	3.50									
s	8	10	13	17	19	22	24	30	36	46									
Length/dim	M5	M6	M8	M10	M12	M14	M16	M20	M24	M30									
15	■																		
18		■ ◆																	
24			■ ◆																
30				■ ◆															
36					■ ◆														
42						■ ◆													
48							■ ◆												
60								■ ◆											
72									■ ◆										
90										■ ◆									

[CLICK HERE TO RETURN TO THE CONTENTS PAGE](#)



+ 37 064 411 786



Inquiry@invayear.com

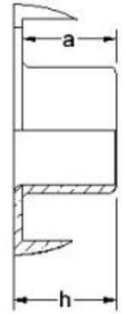
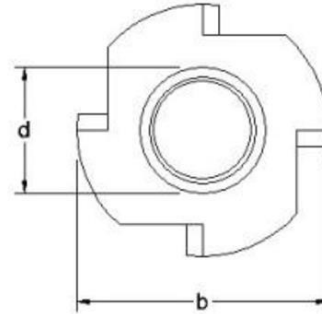

www.invayear.com

TEE-NUT
4 PRONG DRIVE IN NUTS FOR WOOD (TEE-NUT)

Material grades: A2: ■

a (Min)	3.1	3.5	6.8	9.4															
b	17	19	22	25															
h	8	9	11	12															
Pitch	0.8	1.00	1.25	1.50															
Length/dim	M5	M6	M8	M10															
	■	■	■	■															

[CLICK HERE TO RETURN TO THE CONTENTS PAGE](#)

+ 37 064 411 786

Inquiry@invayear.com

www.invayear.com

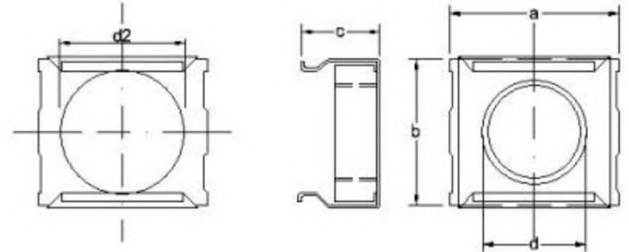
CAGE NUTS

Material grades: A2: ■

a	13.8	16.5	16.5																	
b	13	15.5	15.5																	
c	9.3	12	12																	
d2	7	10.5	10.5																	
Pitch	1.00	1.25	1.50																	
Length/dim	M6	M8	M10																	
	■	■	■																	

[CLICK HERE TO RETURN TO THE CONTENTS PAGE](#)



+ 37 064 411 786

Inquiry@invayear.com

www.invayear.com

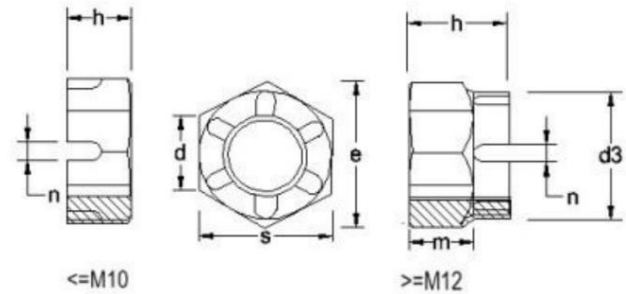
HEXAGON CASTLE NUTS DIN 935

Material grades: A2: ■ A4: ◆

d3	-	-	-	-	17	19	22	25	28	34	38	42	50				
e	8.87	11.05	14.38	18.90	21.10	24.49	26.75	30.14	33.53	39.98	45.63	51.28	55.80				
h	6.0	7.5	9.5	12.0	15.0	16.0	19.0	21.0	22.0	27.0	30.0	33.0	38.0				
m	4.0	5.0	6.5	8.0	10.0	11.0	13.0	15.0	16.0	19.0	22.0	24.0	29.0				
n	1.4	2.0	2.5	2.8	3.5	3.5	4.5	4.5	4.5	5.5	5.5	7.0	7.0				
Pitch	0.80	1.00	1.25	1.50	1.75	2.00	2.00	2.50	2.50	3.00	3.00	3.50	4.00				
s	8	10	13	17	19	22	24	27	30	36	41	46	55				
Length/dim	M5	M6	M8	M10	M12	M14	M16	M18	M20	M24	M27	M30	M36				
	■ ◆	■ ◆	■ ◆	■ ◆	■ ◆	■ ◆	■ ◆	■ ◆	■ ◆	■ ◆	■ ◆	■ ◆	■ ◆				

[CLICK HERE TO RETURN TO THE CONTENTS PAGE](#)

+ 37 064 411 786

Inquiry@invayear.com

www.invayear.com

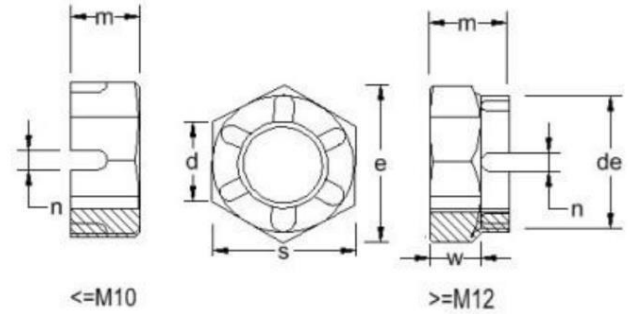
HEXAGON CASTLE NUTS THIN TYPE DIN 937

Material grades: A2: ■ A4: ◆

de (Min)	-	-	-	16.57	18.48	21.48	24.30	27.30	33.00	37.00	41.00						
e	11.05	14.38	18.90	20.10	24.49	26.75	29.56	32.95	39.55	45.20	50.85						
m (Min)	5.7	7.64	8.64	9.64	10.57	11.57	12.30	12.30	14.30	16.30	17.30						
n (Min)	2.0	2.5	2.8	3.5	3.5	4.5	4.5	4.5	5.5	5.5	7.0						
Pitch	1.00	1.25	1.50	1.75	2.00	2.00	2.50	2.50	3.00	3.00	3.50						
s	10	13	17	19	22	24	27	30	36	41	46						
w	3.5	4.5	5.0	6.0	7.0	7.0	8.0	8.0	9.0	11.0	11.0						
Length/dim	M6	M8	M10	M12	M14	M16	M18	M20	M24	M27	M30						
	■ ◆	■ ◆	■ ◆	■ ◆	■ ◆	■ ◆	■ ◆	■ ◆	■ ◆	■ ◆	■ ◆						

[CLICK HERE TO RETURN TO THE CONTENTS PAGE](#)

+ 37 064 411 786

Inquiry@invayear.com

www.invayear.com

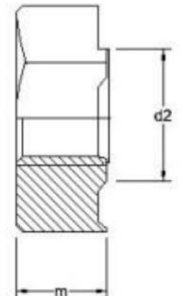
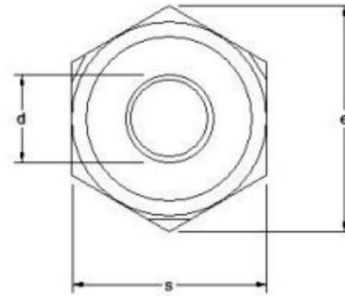

Material grades: A2: ■ A4: ◆

d2	4.5	6.0	7.0	8.0	10.5	12.5	14.8	18.8									
e	8.15	9.83	10.95	12.02	15.38	18.74	20.91	26.51									
m	3.0	3.5	4.0	5.0	6.5	8.0	10.0	13.0									
Pitch	0.50	0.70	0.80	1.00	1.25	1.50	1.75	2.00									
s	7.5	9	10	11	14	17	19	24									
Length/dim	M3	M4	M5	M6	M8	M10	M12	M16									
	■ ◆	■ ◆	■ ◆	■ ◆	■ ◆	■ ◆	■ ◆	■ ◆									

CLICK HERE TO RETURN TO THE CONTENTS PAGE



+ 37 064 411 786



Inquiry@invayear.com



www.invayear.com

NUTS

NYLON INSERT NUTS THIN TYPE

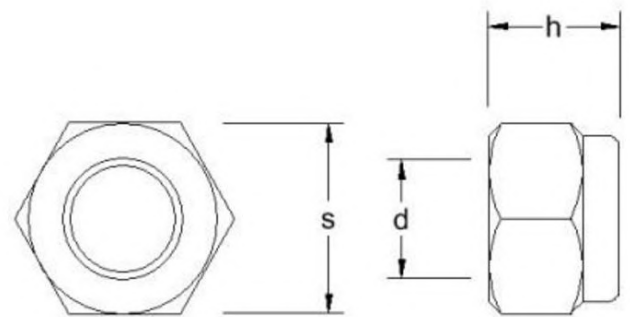

Material grades: A2: ■ A4: ◆

h	0.109	0.125	0.172	0.172	0.172	0.203	0.203	0.250	0.250	0.266	0.266	0.313	0.313	0.313	0.313	0.391	0.391
s (Max)	0.250	0.312	0.344	0.375	0.375	0.438	0.438	0.500	0.500	0.563	0.563	0.688	0.688	0.750	0.750	0.938	0.938
Length/dim	4-40	6-32	8-32	10-24	10-32	1/4-20	1/4-28	5/16-18	5/16-24	3/8-16	3/8-24	7/16-14	7/16-20	1/2-13	1/2-20	5/8-11	5/8-18
	■ ◆	■ ◆	■ ◆	■ ◆	■ ◆	■ ◆	■ ◆	■ ◆	■ ◆	■ ◆	■ ◆	■	■	■ ◆	■ ◆	■ ◆	■

h	0.408	0.562															
s (Max)	1.063	1.440															
Length/dim	3/4-10	1-8															
	■ ◆	■ ◆															

[CLICK HERE TO RETURN TO THE CONTENTS PAGE](#)



+ 37 064 411 786



Inquiry@invayear.com

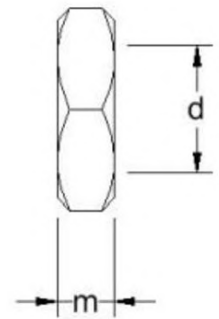
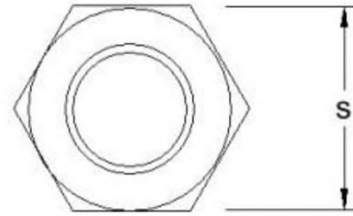

www.invayear.com

USA SMALL PATTERN HEXAGON NUTS

Material grades: A2: ■

m (Max)	0.047	0.047	0.062	0.062	0.093	0.093	0.109	0.125	0.125								
s (Max)	0.125	0.125	0.156	0.187	0.250	0.250	0.312	0.343	0.343								
Length/dim	0-80	1-64	2-56	4-40	5-40	6-32	8-32	10-24	10-32								
1/8AF	■	■															
5/32AF			■														
3/16AF				■													
1/4AF					■	■	■										
5/16AF							■	■	■								
11/32AF								■	■								

[CLICK HERE TO RETURN TO THE CONTENTS PAGE](#)



+ 37 064 411 786



Inquiry@invayear.com



www.invayear.com

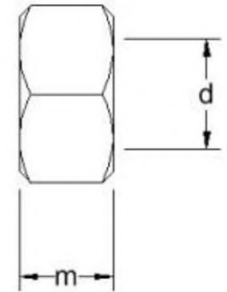
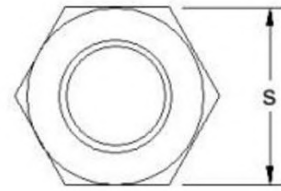

Material grades: A2: ■ A4: ◆

m (Max)	0.250	0.250	0.314	0.314	0.377	0.377	0.441	0.441	0.504	0.504	0.568	0.568	0.631	0.631	0.758	0.758	0.885
s (Max)	0.500	0.500	0.562	0.562	0.687	0.687	0.750	0.750	0.875	0.875	0.937	0.937	1.062	1.062	1.250	1.250	1.437
Length/dim	1/4-20	1/4-28	5/16-18	5/16-24	3/8-16	3/8-24	7/16-14	7/16-20	1/2-13	1/2-20	9/16-12	9/16-18	5/8-11	5/8-18	3/4-10	3/4-16	7/8-9
	■◆	■	■◆	■	■◆	■	■◆	■	■◆	■	■	■	■◆	■	■◆	■	■◆

m (Max)	0.885	1.012	1.012														
s (Max)	1.437	1.625	1.625														
Length/dim	7/8-14	1-8	1-12														
	■	■◆	■														

[CLICK HERE TO RETURN TO THE CONTENTS PAGE](#)



+ 37 064 411 786



Inquiry@invayear.com

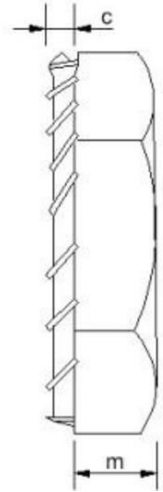
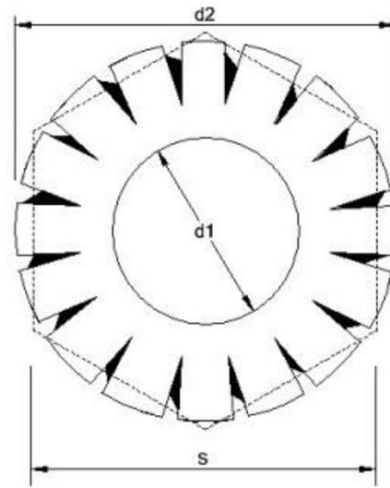

www.invayear.com

USA KEP NUTS

 Material grades: **A2**

c	0.014	0.018	0.021	0.023	0.023	0.026	0.026	0.031	0.031	0.031	0.031						
d2	0.281	0.343	0.375	0.406	0.406	0.500	0.500	0.578	0.578	0.656	0.656						
m	0.094	0.109	0.125	0.125	0.125	0.218	0.218	0.265	0.265	0.328	0.328						
s	0.250	0.312	0.344	0.375	0.375	0.438	0.438	0.500	0.500	0.562	0.562						
Length/dim	4-40	6-32	8-32	10-24	10-32	1/4-20	1/4-28	5/16-18	5/16-24	3/8-16	3/8-24						
	■	■	■	■	■	■	■	■	■	■	■						

[CLICK HERE TO RETURN TO THE CONTENTS PAGE](#)



+ 37 064 411 786



Inquiry@invayear.com



www.invayear.com

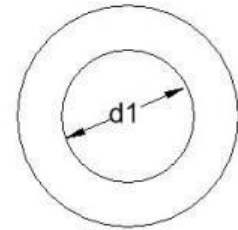
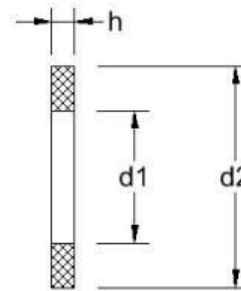

Material grades: A2: ■ A4: ◆

d1	1.1	1.3	1.5	1.7	1.8	2.2	2.7	3.2	3.7	4.3	5.3	6.4	7.4	8.4	10.5	13	15
d2	3.2	3.8	3.8	4	4.5	5	6	7	8	9	10	12	14	16	20	24	28
h	0.3	0.3	0.3	0.3	0.3	0.3	0.5	0.5	0.5	0.8	1	1.6	1.6	1.6	2	2.5	2.5
Length/dim	M1	M1.2	M1.4	M1.6	M1.7	M2	M2.5	M3	M3.5	M4	M5	M6	M7	M8	M10	M12	M14
	■	■	■	◆	■	◆	◆	◆	◆	◆	◆	◆	◆	◆	◆	◆	◆

d1	17	19	21	23	25	28	31	34	37	40	43	46	50	54	58		
d2	30	34	37	39	44	50	56	60	66	66	75	85	92	98	105		
h	3	3	3	3	4	4	4	5	5	6	7	7	8	8	9		
Length/dim	M16	M18	M20	M22	M24	M27	M30	M33	M36	M39	M42	M45	M48	M52	M56		
	◆	◆	◆	◆	◆	◆	◆	◆	◆	◆	◆	◆	◆	◆	◆		

[CLICK HERE TO RETURN TO THE CONTENTS PAGE](#)



+ 37 064 411 786



Inquiry@invayear.com

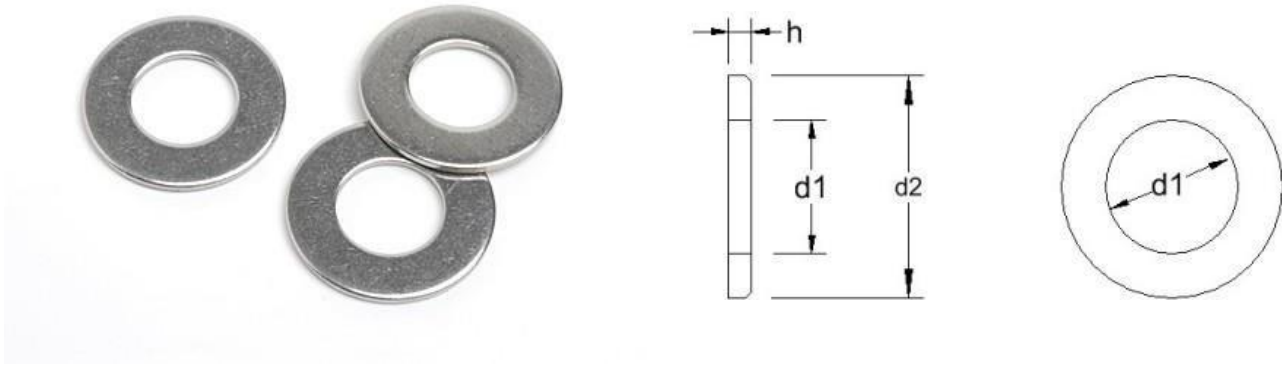

www.invayear.com

FORM B FLAT WASHERS BS4320

Material grades: A2: ■ A4: ◆

d1	5.3	6.4	8.4	10.5	13	15	17	19	21	23	25								
d2	10	12.5	17	21	24	28	30	34	37	39	44								
h	0.8	0.8	1	1.25	1.6	1.6	2	2	2	2	2.5								
Length/dim	M5	M6	M8	M10	M12	M14	M16	M18	M20	M22	M24								
	◆	◆	◆	◆	◆	◆	◆	◆	◆	◆	◆								

[CLICK HERE TO RETURN TO THE CONTENTS PAGE](#)



+ 37 064 411 786

Inquiry@invayear.com

www.invayear.com

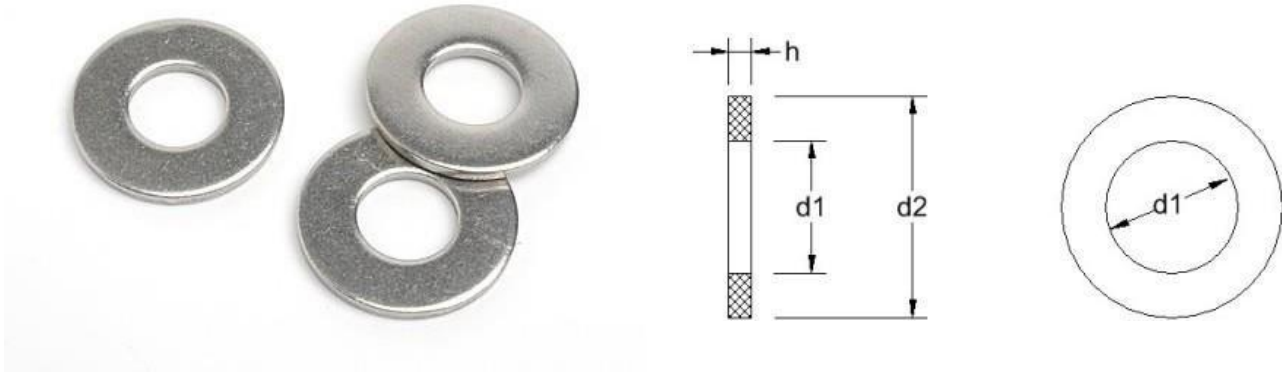
WASHERS BS4320
FORM C FLAT WASHERS BS4320

Material grades: A2: ■ A4: ◆

d1	4.3	5.3	6.4	8.4	10.5	13	17	21										
d2	10	12.5	14	21	24	28	34	39										
h (Max)	0.8	1	1.6	1.6	2	2.5	3	3										
Length/dim	M4	M5	M6	M8	M10	M12	M16	M20										
	■◆	■◆	■◆	■◆	■◆	■◆	■◆	■◆										

[CLICK HERE TO RETURN TO THE CONTENTS PAGE](#)



+ 37 064 411 786

Inquiry@invayear.com

www.invayear.com

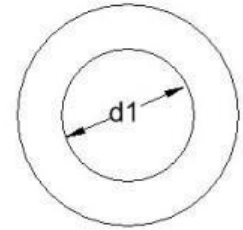
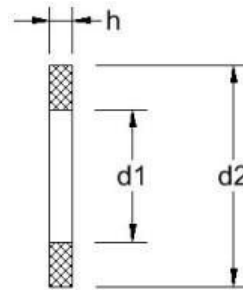
PENNY WASHERS

Material grades: A2: ■ A4: ◆

d1	4.3	4.3	5.3	6.4	8.4	10.5	13											
h (Max)	1	1.5	1.5	1.5	1.5	1.5	1.5											
Length/dim	M4	M4	M5	M6	M8	M10	M12											
12	■ ◆																	
15		■ ◆	■ ◆															
20		■ ◆	■ ◆	■ ◆	■ ◆													
25		■ ◆	■ ◆	■ ◆	■ ◆	■ ◆												
30			■ ◆	■ ◆	■ ◆	■ ◆	■ ◆											
35				■ ◆	■ ◆	■ ◆	■ ◆											
40				■ ◆	■ ◆	■ ◆	■ ◆											

[CLICK HERE TO RETURN TO THE CONTENTS PAGE](#)

+ 37 064 411 786

Inquiry@invayear.com

www.invayear.com

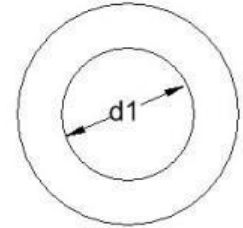
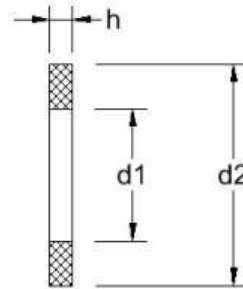

Material grades: A2: ■ A4: ◆

d1	5.5	6.6	9	11	13.5	17.5	22	24	26	30										
d2	18	22	28	34	44	56	72	80	85	98										
h	2	2	3	3	4	5	6	6	6	6										
Length/dim	M5	M6	M8	M10	M12	M16	M20	M22	M24	M27										
	◆	◆	◆	◆	◆	◆	◆	◆	◆	◆	■									

[CLICK HERE TO RETURN TO THE CONTENTS PAGE](#)



+ 37 064 411 786

Inquiry@invayear.com

www.invayear.com

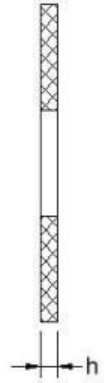
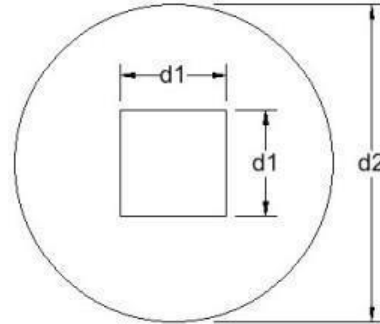
WOOD CONSTRUCTION WASHERS (SQUARE HOLE) DIN 440V

Material grades: A2: ■ A4: ◆

d1	5.5	6.6	9	11	14	18	22	26										
d2	18	22	28	34	44	56	72	85										
h (Max)	2	2	3	3	4	5	6	6										
Length/dim	M5	M6	M8	M10	M12	M16	M20	M24										
	■ ◆	■ ◆	■ ◆	■ ◆	■ ◆	■ ◆	■ ◆	■ ◆										

[CLICK HERE TO RETURN TO THE CONTENTS PAGE](#)



+ 37 064 411 786



Inquiry@invayear.com



www.invayear.com

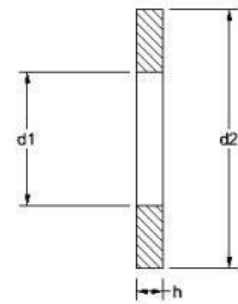
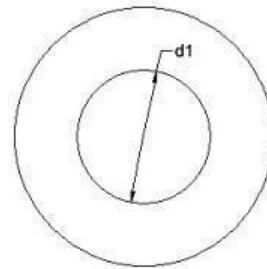

Material grades: A2: ■ A4: ◆

d1	3.2	4.3	5.3	6.4	8.4	10.5	13	15	17	19	21	23	25	28	31		
d2	9	12	15	17	21	25	30	36	40	44	44	50	50	60	68		
h	1.0	01.6	2.0	3.0	4.0	4.0	6.0	6.0	6.0	8.0	8.0	8.0	10.0	10.0	10.0		
Length/dim	M3	M4	M5	M6	M8	M10	M12	M14	M16	M18	M20	M22	M24	M27	M30		
	■◆	■◆	■◆	■◆	■◆	■◆	■◆	■◆	■◆	■◆	■◆	■◆	■◆	■◆	■◆		

[CLICK HERE TO RETURN TO THE CONTENTS PAGE](#)



+ 37 064 411 786



Inquiry@invayear.com

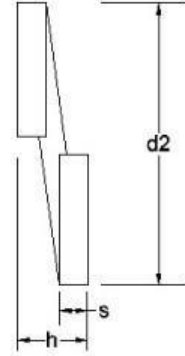
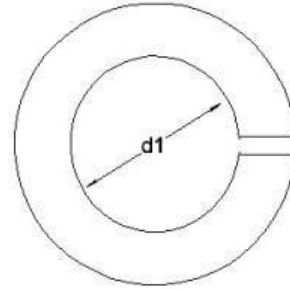

www.invayear.com

RECTANGULAR SECTION SPRING WASHERS DIN 127B

Material grades: A2: ■ A4: ◆

d1 (Min)	*	2.1	2.6	2.7	3.1	3.6	4.1	5.1	6.1	7.1	8.1	10.2	12.2	14.2	16.2	18.2	20.2	
d2 (Max)	*	4.4	5.1	5.2	6.2	6.7	7.6	9.2	11.8	12.8	14.8	18.1	21.1	24.1	27.4	29.4	33.6	
h	*	1	1.2	1.2	1.6	1.6	1.8	2.4	3.2	3.2	4	4.4	5	6	7	7	8	
s	*	0.5	0.6	0.6	0.8	0.8	0.9	1.2	1.6	1.6	2	2.2	2.5	3	3.5	3.5	4	
Length/dim		M1.6	M2	M2.5	M2.6	M3	M3.5	M4	M5	M6	M7	M8	M10	M12	M14	M16	M18	M20
		■◆	■◆	■◆	◆	■◆	■◆	■◆	■◆	■◆	■◆	■◆	■◆	■◆	■◆	■◆	■◆	■◆

d1 (Min)	22.5	24.5	27.5	30.5	33.5	36.5	39.5										
d2 (Max)	35.9	40	43	48.2	48.2	56	60										
h	8	10	10	12	12	12	12										
s	4	5	5	6	6	6	6										
Length/dim	M22	M24	M27	M30	M33	M36	M39										
	■◆	■◆	■◆	■◆	■◆	■◆	■◆										

[CLICK HERE TO RETURN TO THE CONTENTS PAGE](#)



+ 37 064 411 786



Inquiry@invayear.com

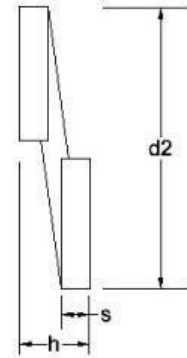
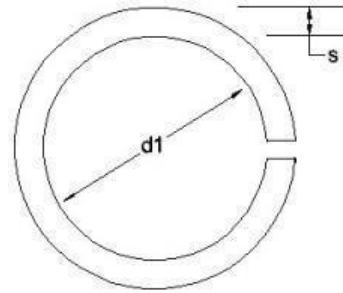

www.invayear.com

SQUARE SECTION SPRING WASHERS DIN 7980

Material grades: A2: ■ A4: ◆

d1 (Min)	2.1	2.6	3.1	3.6	4.1	5.1	6.1	8.1	10.2	12.2	14.2	16.2	18.2	20.2	22.5	24.5	27.5
d2 (Max)	*	*	5.6	6.1	7	8.8	9.9	12.7	16	18	21.1	24.4	26.4	30.6	32.9	35.9	38.9
h	*	*	2	2	2.4	3.2	3.2	4	5	5	6	7	7	9	9	10	10
s	*	*	1	1	1.2	1.6	1.6	2	2.5	2.5	3	3.5	3.5	4.5	4.5	5	5
Length/dim	M2	M2.5	M3	M3.5	M4	M5	M6	M8	M10	M12	M14	M16	M18	M20	M22	M24	M27
	■◆	■◆	■◆	■◆	■◆	■◆	■◆	■◆	■◆	■◆	■◆	■◆	■◆	■◆	■◆	■◆	■◆

d1 (Min)	30.5																
d2 (Max)	44.1																
h	12																
s	6																
Length/dim	M30																
	■◆																

[CLICK HERE TO RETURN TO THE CONTENTS PAGE](#)



+ 37 064 411 786



Inquiry@invayear.com

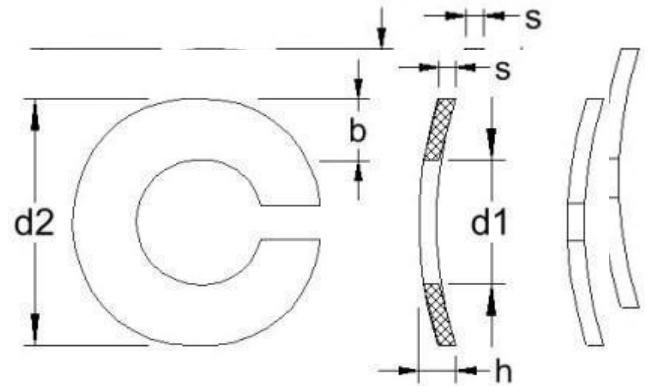

www.invayear.com

DIN 128A CURVED SPRING WASHERS

Material grades: A2: ■ A4: ◆

b	0.9	0.9	1.0	1.0	1.3	1.3	1.5	1.8	2.5	3.0	3.5	4.0	4.5	5.0	5.0	6.0	6.0
d1 (Min)	2.1	2.4	2.6	2.7	3.1	3.6	4.1	5.1	6.1	8.1	10.2	12.2	14.2	16.2	18.2	20.2	22.5
d2 (Max)	4.4	4.9	5.1	5.2	6.2	6.7	7.6	9.2	11.8	14.8	18.1	21.1	24.1	27.4	29.4	33.6	35.9
h	0.70-0.90	0.90-1.10	0.90-1.10	0.90-1.10	1.10-1.30	1.10-1.30	1.20-1.40	1.50-1.70	2.00-2.20	2.45-2.75	2.85-3.15	3.35-3.65	3.90-4.30	4.50-5.10	4.50-5.10	5.90-5.10	5.90-5.90
s	0.5	0.6	0.6	0.6	0.7	0.7	0.8	1.0	1.3	1.6	1.8	2.1	2.4	2.8	2.8	3.2	3.2
Length/dim	M2	M2.3	M2.5	M2.6	M3	M3.5	M4	M5	M6	M8	M10	M12	M14	M16	M18	M20	M22
	■◆	■◆	■◆	■◆	■◆	■◆	■◆	■◆	■◆	■◆	■◆	■◆	■◆	■◆	■◆	■◆	■◆

b	7.0	7.0	8.0	10.0													
d1 (Min)	24.5	27.5	30.5	36.5													
d2 (Max)	40.0	43.0	48.2	58.2													
h	6.50-7.50	6.50-7.50	9.50-10.50	10.30-11.30													
s	4.0	4.0	6.0	6.0													
Length/dim	M24	M27	M30	M36													
	■◆	■◆	■◆	■◆													

[CLICK HERE TO RETURN TO THE CONTENTS PAGE](#)



+ 37 064 411 786



Inquiry@invayear.com



www.invayear.com

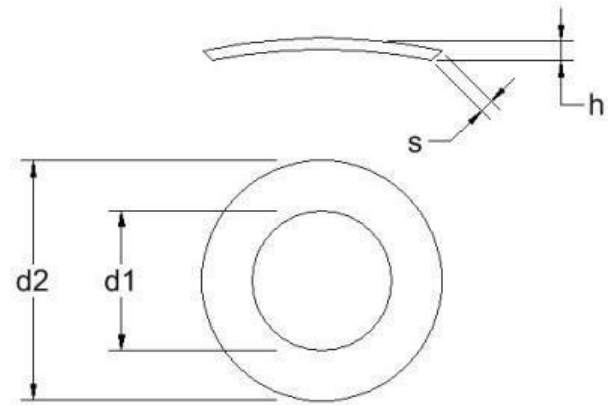

Material grades: A2:■

d1	1.5	1.7	1.8	2.2	2.5	2.8	2.8	3.2	3.7	4.3	5.3	6.4	7.4	8.4	10.5		
d2	3.0	4.0	4	4.5	5	5.5	5.5	6	7	8	10	11	12	15	18		
h (Max)	0.7	0.9	0.9	1	1	1.1	1.1	1.3	1.4	1.6	1.8	2.2	2.4	3.4	4		
s	0.25	0.25	0.3	0.3	0.3	0.3	0.3	0.4	0.4	0.5	0.5	0.5	0.5	0.5	0.8		
Length/dim	M1.4	M1.6	M1.7	M2	M2.3	M2.5	M2.6	M3	M3.5	M4	M5	M6	M7	M8	M10		
	■	■	■	■	■	■	■	■	■	■	■	■	■	■	■		

[CLICK HERE TO RETURN TO THE CONTENTS PAGE](#)



+ 37 064 411 786



Inquiry@invayear.com

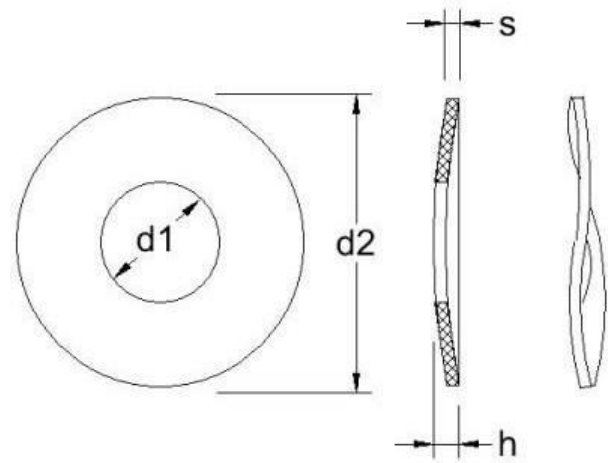

www.invayear.com

DIN 137B WAVE WASHERS

Material grades: A2: ■ A4: ◆

d1	3.2	3.7	4.3	5.3	6.4	7.4	8.4	10.5	13	15	17	19	21	23	25	28	
d2	8	8	9	11	12	14	15	21	24	28	30	34	36	40	44	50	
h (Max)	1.6	1.8	2	2.2	2.6	3	3	4.2	5	6	6.4	6.6	7.4	7.8	8.2	9.4	
s	0.5	0.5	0.5	0.5	0.5	0.8	0.8	1	1.2	1.6	1.6	1.6	1.6	1.8	1.8	2.0	
Length/dim	M3	M3.5	M4	M5	M6	M7	M8	M10	M12	M14	M16	M18	M20	M22	M24	M27	
	◆	■	◆	◆	◆	■	◆	■	■	■	■	■	■	■	■	■	

[CLICK HERE TO RETURN TO THE CONTENTS PAGE](#)



+ 37 064 411 786



Inquiry@invayear.com



www.invayear.com

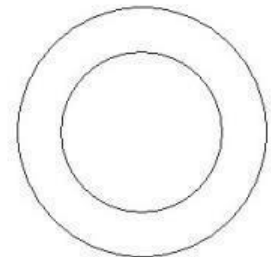
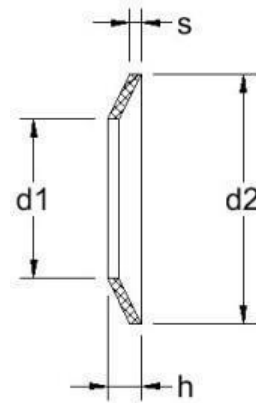

Material grades: A2: ■ A4: ◆

d1	3.2	4.3	5.3	6.4	8.4	10.5	13	15	17	19	21	23	25				
d2	7	9	11	14	18	23	29	35	39	42	45	49	56				
h	0.72-0.85	1.12-1.30	1.35-1.55	1.70-2.00	2.24-2.60	2.80-3.20	3.43-3.95	4.04-4.65	4.58-5.25	5.08-5.80	5.60-6.40	6.15-7.05	6.77-7.75				
s	0.60	1.00	1.20	1.50	2.00	2.50	3.00	3.50	4.00	4.50	5.00	5.50	6.00				
Length/dim	M3	M4	M5	M6	M8	M10	M12	M14	M16	M18	M20	M22	M24				
	■◆	■◆	■◆	■◆	■◆	■◆	■◆	■◆	■◆	■◆	■◆	■◆	■◆				

CLICK HERE TO RETURN TO THE CONTENTS PAGE



+ 37 064 411 786



Inquiry@invayear.com

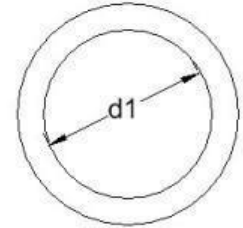
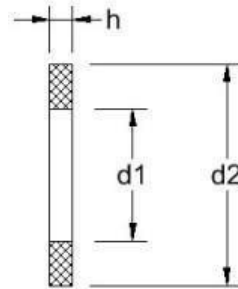

www.invayear.com

DIN 433 FLAT WASHERS

Material grades: A2: ■ A4: ◆

d1	1.5	1.7	2.2	2.7	3.2	3.7	4.3	5.3	6.4	8.4	10.5	13	15	17	19	21	
d2	3	3.5	4.5	5	6	7	8	9	11	15	18	20	24	28	30	34	
h	0.3	0.3	0.3	0.5	0.5	0.5	0.5	1	1.6	1.6	1.6	2	2.5	2.5	2.5	3	
Length/dim	M1.4	M1.6	M2	M2.5	M3	M3.5	M4	M5	M6	M8	M10	M12	M14	M16	M18	M20	
	■	◆	◆	◆	◆	◆	◆	◆	◆	◆	◆	◆	◆	◆	◆	◆	◆

[CLICK HERE TO RETURN TO THE CONTENTS PAGE](#)



+ 37 064 411 786

Inquiry@invayear.com

www.invayear.com

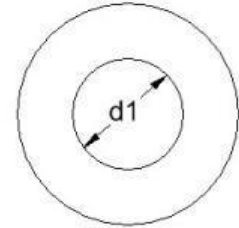
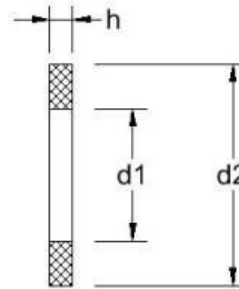

Material grades: A2: ■ A4: ◆

d1	2.2	2.7	3.2	3.7	4.3	5.3	6.4	7.4	8.4	10.5	13	15	17	20	22	26	33
d2	7	8	9	11	12	15	18	22	24	30	37	44	50	56	60	72	92
h	0.8	0.8	0.8	0.8	1	1.2	1.6	2	2	2.5	3	3	3	4	4	5	6
Length/dim	M2	M2.5	M3	M3.5	M4	M5	M6	M7	M8	M10	M12	M14	M16	M18	M20	M24	M30
	■◆	■◆	■◆	■◆	■◆	■◆	■◆	■◆	■◆	■◆	■◆	■◆	■◆	■◆	■◆	■◆	■◆

d1	39																
d2	110																
h	8																
Length/dim	M36																
	■◆																

CLICK HERE TO RETURN TO THE CONTENTS PAGE



+ 37 064 411 786



Inquiry@invayear.com

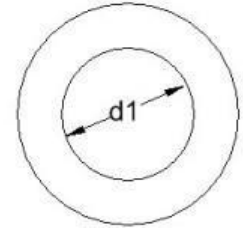
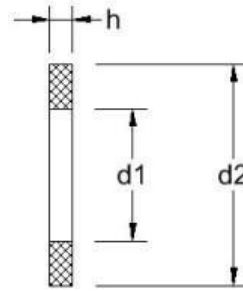

www.invayear.com

ISO 7089 FLAT WASHERS 200HV

Material grades: A2: ■ A4: ◆

d1	1.7	2.2	2.7	3.2	4.3	5.3	6.4	8.4	10.5	13	15	17	21	25	28	31	34
d2	4	5	6	7	9	10	12	16	20	24	28	30	37	44	50	56	60
h	0.3	0.3	0.5	0.5	0.8	1	1.6	1.6	2	2.5	2.5	3	3	4	4	4	5
Length/dim	M1.6	M2	M2.5	M3	M4	M5	M6	M8	M10	M12	M14	M16	M20	M24	M27	M30	M33
	■◆	■◆	■◆	■◆	■◆	■◆	■◆	■◆	■◆	■◆	■◆	■◆	■◆	■◆	■◆	■◆	■◆

d1	37	40	43	46	50	54	*										
d2	66	66	75	85	92	98	*										
h	5	6	7	7	8	8	*										
Length/dim	M36	M39	M42	M45	M48	M52	M56										
	■◆	■◆	■◆	■◆	■◆	■◆	■◆										

[CLICK HERE TO RETURN TO THE CONTENTS PAGE](#)



+ 37 064 411 786



Inquiry@invayear.com



www.invayear.com

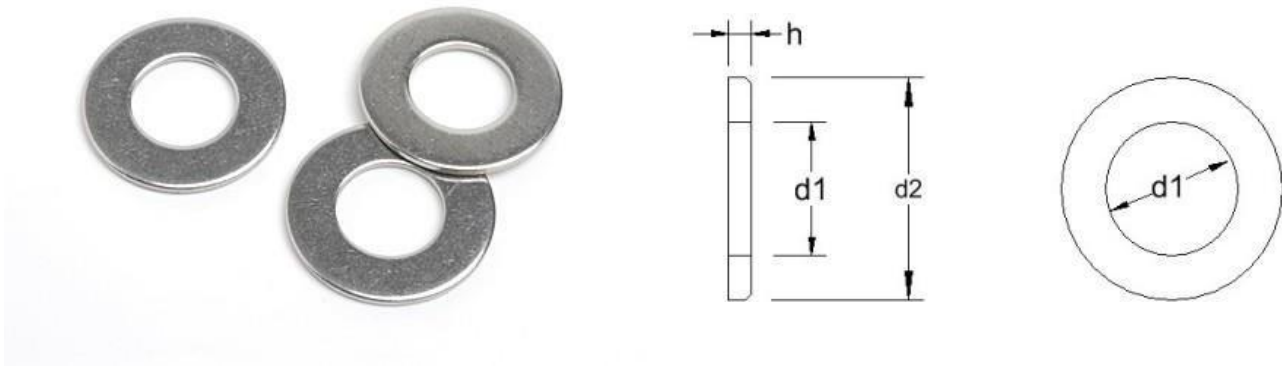

Material grades: A2: ■ A4: ◆

d1 Min	5.3	6.4	8.4	10.5	13	15	17	19	21	23	25	28	31	34	37	42	45
d2 Max	10	12	16	20	24	28	30	34	37	39	44	50	56	60	66	72	78
h	1	1.6	1.6	2	2.5	2.5	3	3	3	3	4	4	4	5	5	6	8
Length/dim	M5	M6	M8	M10	M12	M14	M16	M18	M20	M22	M24	M27	M30	M33	M36	M39	M42
	■◆	■◆	■◆	■◆	■◆	■◆	■◆	■◆	■◆	■◆	■◆	■◆	■◆	■◆	■◆	■◆	■◆

d1 Min	48	52															
d2 Max	85	92															
h	8	8															
Length/dim	M45	M48															
	■◆	■◆															

CLICK HERE TO RETURN TO THE CONTENTS PAGE



+ 37 064 411 786



Inquiry@invayear.com

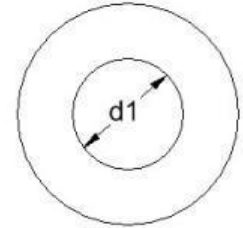
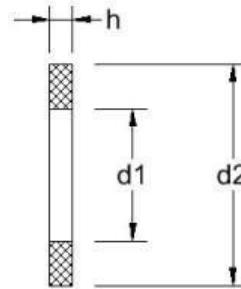

www.invayear.com

ISO 7093-1 LARGE SERIES FLAT WASHERS 200HV

Material grades: A2: ■ A4: ◆

d1 Min	3.2	3.7	4.3	5.3	6.4	8.4	10.5	13	15	17	19	21	23	25	30	33	36
d2 Max	9	11	12	15	18	24	30	37	44	50	56	60	66	72	85	92	105
h	0.8	0.8	1	1	1.6	2	2.5	3	3	3	4	4	5	5	6	6	6
Length/dim	M3	M3.5	M4	M5	M6	M8	M10	M12	M14	M16	M18	M20	M22	M24	M27	M30	M33
	■◆	■◆	■◆	■◆	■◆	■◆	■◆	■◆	■◆	■◆	■◆	■◆	■◆	■◆	■◆	■◆	■◆

d1 Min	39																
d2 Max	110																
h	8																
Length/dim	M36																
	■◆																

[CLICK HERE TO RETURN TO THE CONTENTS PAGE](#)



+ 37 064 411 786



Inquiry@invayear.com



www.invayear.com

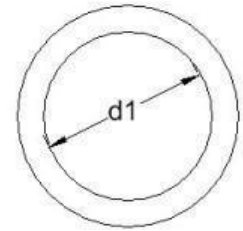
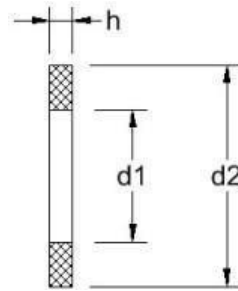

Material grades: A2:■

d1	3.0	4.0	5.0	6.0	8.0	7.0	8.0	10.0	11.0	12.0	13.0	8.0	14.0	15.0	15.0	16.0	17.0
Thickness/d2	6.0	8.0	10.0	12.0	12.0	13.0	14.0	16.0	17.0	18.0	19.0	20.0	20.0	21.0	22.0	22.0	24.0
0.0500								■									
0.1000	■	■		■		■	■	■	■	■						■	■
0.1500				■													
0.2000	■	■	■	■		■	■	■	■		■		■			■	■
0.2500				■						■							
0.3000	■	■	■	■		■	■			■					■		■
0.4000	■	■															
0.5000	■		■	■	■		■	■		■	■		■	■	■		■
0.8000																	
1.0000	■	■	■	■		■	■	■	■	■	■		■		■		■
1.2000				■				■		■							
1.5000												■	■	■		■	■
2.0000			■					■						■			
2.5000																	
3.0000																	

[CLICK HERE TO RETURN TO THE CONTENTS PAGE](#)



+ 37 064 411 786



Inquiry@invayear.com

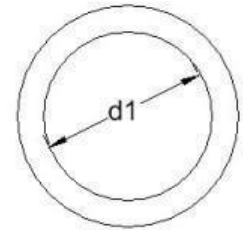
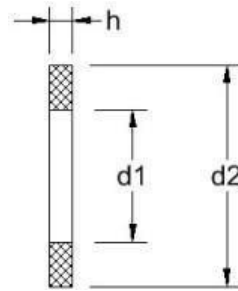

www.invayear.com

DIN 988 SHIM WASHERS

Material grades: A2:■

d1	18.0	20.0	22.0	25.0	26.0	28.0	30.0	30.0	35.0	37.0	40.0	42.0	45.0	50.0	63.0	70.0
Thickness/d2	25.0	28.0	30.0	35.0	37.0	40.0	40.0	42.0	45.0	47.0	50.0	52.0	55.0	62.0	80.0	80.0
0.0500																
0.1000		■					■	■		■	■		■	■	■	■
0.1500																
0.2000	■				■			■		■			■			
0.2500																
0.3000	■					■		■	■	■						
0.4000																
0.5000	■	■			■		■	■		■	■	■				
0.8000			■													
1.0000	■	■		■		■		■		■	■		■	■		
1.2000																
1.5000									■							
2.0000				■		■			■			■				
2.5000											■					
3.0000											■		■			

[CLICK HERE TO RETURN TO THE CONTENTS PAGE](#)



+ 37 064 411 786



Inquiry@invayear.com



www.invayear.com

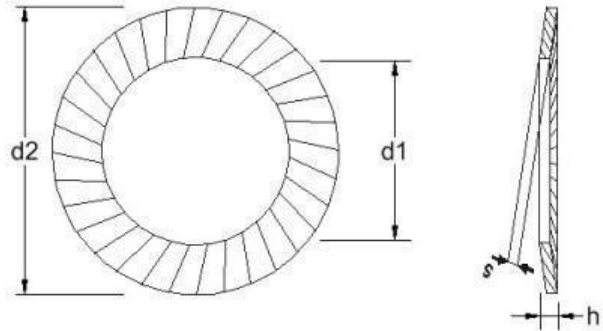

Material grades: A2: ■

d1	2.2	2.7	3.2	3.7	4.3	5.3	6.4	8.4	10.5	13	15	17	19	21	25		
d2	4.0	4.8	5.5	6.0	7.0	9.0	10	13	16	18	22	24	27	30	36		
h (Max)	0.8	0.9	0.9	1.0	1.0	1.1	1.2	1.4	1.6	1.7	2.0	2.1	2.2	2.4	2.7		
s	0.35	0.45	0.45	0.45	0.50	0.60	0.70	0.80	1.00	1.10	1.20	1.30	1.50	1.5	1.8		
Length/dim	M2	M2.5	M3	M3.5	M4	M5	M6	M8	M10	M12	M14	M16	M18	M20	M24		
	■	■	■	■	■	■	■	■	■	■	■	■	■	■	■		

[CLICK HERE TO RETURN TO THE CONTENTS PAGE](#)

+ 37 064 411 786

Inquiry@invayear.com

www.invayear.com

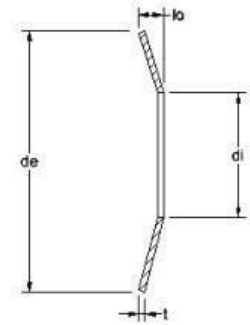
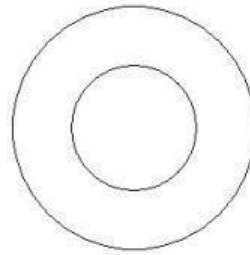
DISC SPRINGS DIN 2093

Material grades: A2: ■

d1	3.2	3.2	4.2	5.2	4.2	6.2	6.2	7.2	8.2	8.2	6.2	9.2	8.2	10.2	12.2	14.2	16.3
Thickness/d2	6	8	8	10	12	12	12.5	14	15	16	18	18	20	20	25	28	31.5
0.2000			■														
0.2500				■													
0.3000	■		■														
0.4000			■	■	■					■	■						
0.5000		■		■	■	■	■						■				
0.6000										■				■			
0.7000							■					■				■	
0.8000								■	■					■			
0.9000										■				■	■		
1.0000												■		■		■	
1.1000														■	■		
1.2500																	■
1.5000															■	■	
1.7500																	■
2.0000																	
2.2500																	

[CLICK HERE TO RETURN TO THE CONTENTS PAGE](#)



+ 37 064 411 786



Inquiry@invayear.com



www.invayear.com

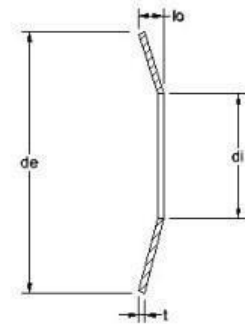
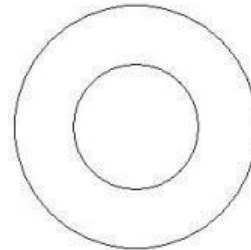

Material grades: A2: ■

dI	18.3	20.4																	
Thickness/d2	35.5	40																	
0.2000																			
0.2500																			
0.3000																			
0.4000																			
0.5000																			
0.6000																			
0.7000																			
0.8000																			
0.9000																			
1.0000																			
1.1000																			
1.2500	■																		
1.5000		■																	
1.7500																			
2.0000	■	■																	
2.2500		■																	

[CLICK HERE TO RETURN TO THE CONTENTS PAGE](#)



+ 37 064 411 786



Inquiry@invayear.com

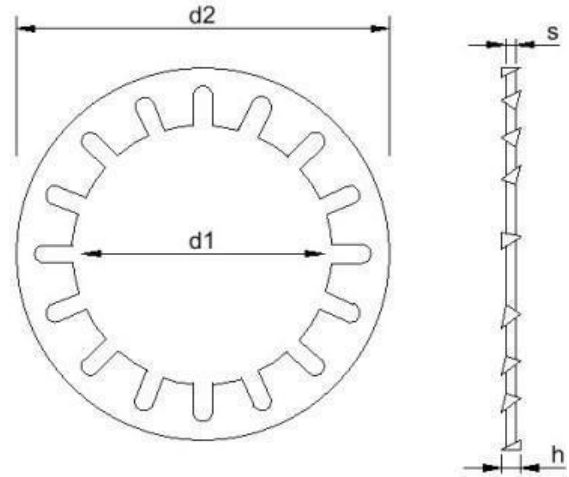

www.invayear.com

INTERNAL TOOTH WASHERS DIN 6797 J

Material grades: A2: ■

d1 (Min)	2.2	2.7	3.2	3.7	4.3	5.3	6.4	7.4	8.4	10.5	13	15	17	19	21	23	25
d2 (Max)	4.5	5.5	6	7	8	10	11	12.5	15	18	20.5	24	26	30	33	36	38
h (Min)	2 x 's'	2 x 's'	2 x 's'	2 x 's'	2 x 's'	2 x 's'	2 x 's'	2 x 's'	2 x 's'	2 x 's'	2 x 's'	2 x 's'	2 x 's'	2 x 's'	2 x 's'	2 x 's'	2 x 's'
s	0.3	0.4	0.4	0.5	0.5	0.6	0.7	0.8	0.8	0.9	1	1	1.2	1.4	1.4	1.5	1.5
Length/dim	M2	M2.5	M3	M3.5	M4	M5	M6	M7	M8	M10	M12	M14	M16	M18	M20	M22	M24
	■	■	■	■	■	■	■	■	■	■	■	■	■	■	■	■	■

d1 (Min)	28	31															
d2 (Max)	44	48															
h (Min)	2 x 's'	2 x 's'															
s	1.6	1.6															
Length/dim	M27	M30															
	■	■															

[CLICK HERE TO RETURN TO THE CONTENTS PAGE](#)



+ 37 064 411 786



Inquiry@invayear.com

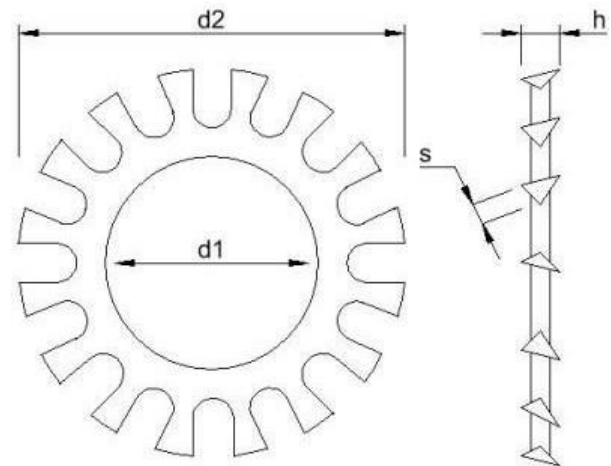

www.invayear.com

EXTERNAL TOOTH WASHERS DIN 6797 A

Material grades: A2: ■

d1 (Min)	2.2	2.7	3.2	3.7	4.3	5.3	6.4	7.4	8.4	10.5	13	15	17	19	21	23	25
d2 (Max)	4.5	5.5	6	7	8	10	11	12.5	15	18	20.5	24	26	30	33	36	38
h (Min)	2 x 's'	2 x 's'	2 x 's'	2 x 's'	2 x 's'	2 x 's'	2 x 's'	2 x 's'	2 x 's'	2 x 's'	2 x 's'	2 x 's'	2 x 's'	2 x 's'	2 x 's'	2 x 's'	2 x 's'
s	0.3	0.4	0.4	0.5	0.5	0.6	0.7	0.8	0.8	0.9	1	1	1.2	1.4	1.4	1.5	1.5
Length/dim	M2	M2.5	M3	M3.5	M4	M5	M6	M7	M8	M10	M12	M14	M16	M18	M20	M22	M24
	■	■	■	■	■	■	■	■	■	■	■	■	■	■	■	■	■

d1 (Min)	28	31															
d2 (Max)	44	48															
h (Min)	2 x 's'	2 x 's'															
s	1.6	1.6															
Length/dim	M27	M30															
	■	■															

[CLICK HERE TO RETURN TO THE CONTENTS PAGE](#)



+ 37 064 411 786



Inquiry@invayear.com

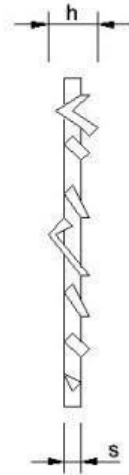
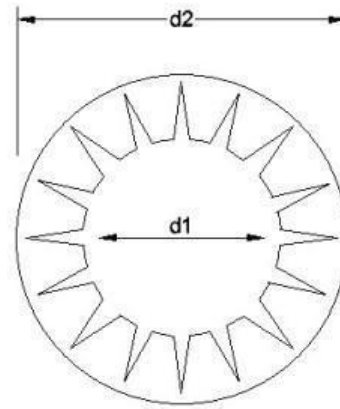

www.invayear.com

INTERNAL TOOTH WASHERS DIN 6798 J

Material grades: A2: ■ A4: ◆

d1	2.2	2.7	3.2	3.7	4.3	5.3	6.4	6.4	8.4	10.5	13	15	17	19	21	23	25
d2 (Max)	4.5	5.5	6	7	8	10	11	12.5	15	18	20.5	24	26	30	33	36	38
h	3 x 'S'	3 x 'S'	3 x 'S'	3 x 'S'	3 x 'S'	3 x 'S'	3 x 'S'	3 x 'S'	3 x 'S'	3 x 'S'	3 x 'S'	3 x 'S'	3 x 'S'	3 x 'S'	3 x 'S'	3 x 'S'	3 x 'S'
s (Max)	0.3	0.4	0.4	0.5	0.5	0.6	0.7	0.8	0.8	0.9	1	1	1.2	1.4	1.4	1.5	1.5
Length/dim	M2	M2.5	M3	M3.5	M4	M5	M6	M7	M8	M10	M12	M14	M16	M18	M20	M22	M24
	■◆	■◆	■◆	■	■◆	■◆	■◆	■	■◆	■◆	■◆	■◆	■◆	■◆	■◆	■◆	■◆

d1	28	31															
d2 (Max)	44	48															
h	3 x 'S'	3 x 'S'															
s (Max)	1.6	1.6															
Length/dim	M27	M30															
	■◆	■◆															

CLICK HERE TO RETURN TO THE CONTENTS PAGE



+ 37 064 411 786



Inquiry@invayear.com

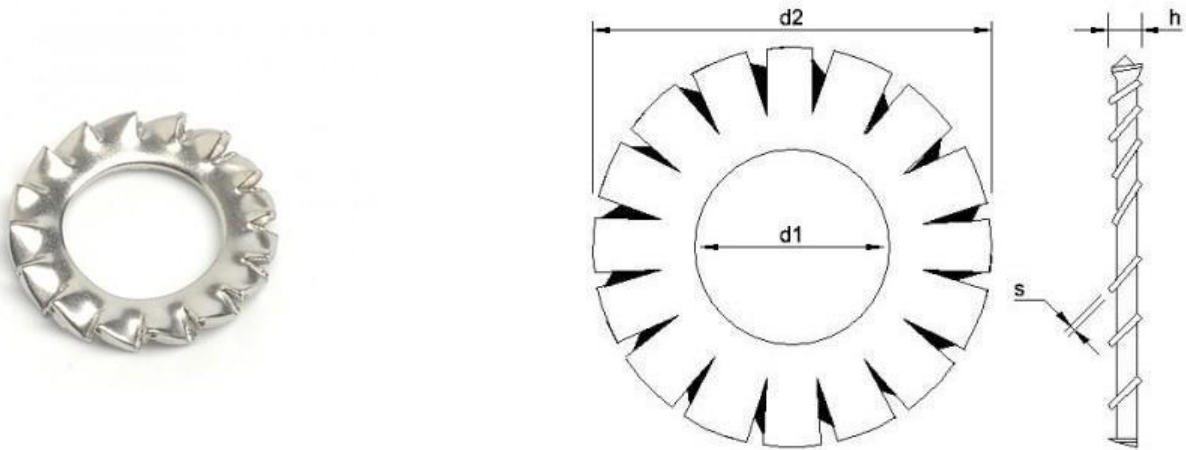

www.invayear.com

EXTERNAL TOOTH WASHERS DIN 6798 A

Material grades: A2: ■ A4: ◆

d1 (Min)	2.2	2.7	3.2	3.7	4.3	5.3	6.4	7.4	8.4	10.5	13	15	17	19	21	23	25
d2 (Max)	4.5	5.5	6	7	8	10	11	12.5	15	18	20.5	24	26	30	33	36	38
h	3 x 's'	3 x 's'	3 x 's'	3 x 's'	3 x 's'	3 x 's'	3 x 's'	3 x 's'	3 x 's'	3 x 's'	3 x 's'	3 x 's'	3 x 's'	3 x 's'	3 x 's'	3 x 's'	3 x 's'
s	0.3	0.4	0.4	0.5	0.5	0.6	0.7	0.8	0.8	0.9	1	1	1.2	1.4	1.4	1.5	1.5
Length/dim	M2	M2.5	M3	M3.5	M4	M5	M6	M7	M8	M10	M12	M14	M16	M18	M20	M22	M24
	■◆	■◆	■◆	■	■◆	■◆	■◆	■	■◆	■◆	■◆	■◆	■◆	■◆	■◆	■◆	■◆

d1 (Min)	28	31															
d2 (Max)	44	48															
h	3 x 's'	3 x 's'															
s	1.6	1.6															
Length/dim	M27	M30															
	■◆	■◆															

CLICK HERE TO RETURN TO THE CONTENTS PAGE



+ 37 064 411 786



Inquiry@invayear.com

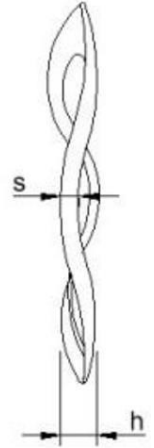
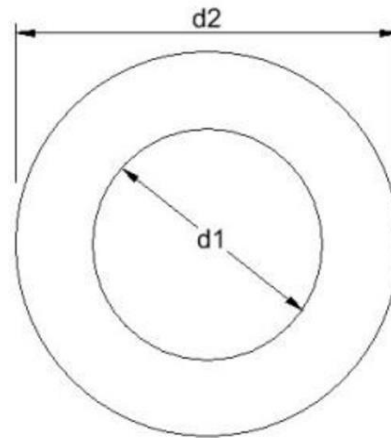

www.invayear.com

CRINKLE WASHERS BS4463

Material grades: A2: ■

d1 (Min)	1.7	2.2	2.7	3.2	3.7	4.3	5.3	6.4	8.4	10.5	13	17	21				
d2 (Max)	3.7	4.6	5.8	6.4	6.9	8.1	9.2	11.5	15	19.6	22	27.8	34.7				
h (Max)	0.51	0.53	0.53	0.61	0.79	0.84	0.89	1.14	1.4	1.7	1.9	2.41	2.66				
s	0.16	0.16	0.16	0.16	0.20	0.28	0.30	0.40	0.40	0.55	0.55	0.70	0.70				
Length/dim	M1.6	M2	M2.5	M3	M3.5	M4	M5	M6	M8	M10	M12	M16	M20				
	■	■	■	■	■	■	■	■	■	■	■	■	■				

[CLICK HERE TO RETURN TO THE CONTENTS PAGE](#)



+ 37 064 411 786



Inquiry@invayear.com



www.invayear.com

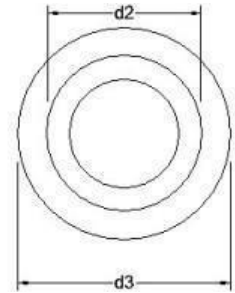
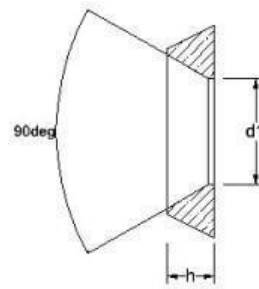

Material grades: A2: ■ A4: ◆

d1	3.5	4.3	5.3	6.4	8.5	11												
d2	6.5	8	10	12	16	20												
d3	9	11	14	16	22	28												
h	2	2.5	3	3.5	4.5	5.5												
Length/dim	M3	M4	M5	M6	M8	M10	M12											
	■◆	■◆	■◆	■◆	■◆	■◆	■◆											

[CLICK HERE TO RETURN TO THE CONTENTS PAGE](#)



+ 37 064 411 786



Inquiry@invayear.com

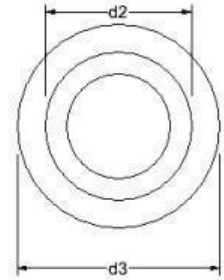
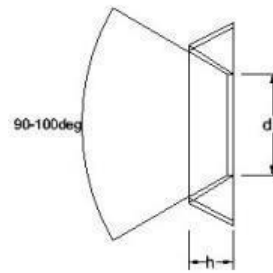

www.invayear.com

STAMPED METAL FINISHING WASHERS (NF E 27-619)

Material grades: A2:■

d1	3.5	4.3	5.3	6.4	8.5	11													
d2	6.5	8	10	12	16	20													
d3	9	11	14	16	22	28													
h	2	2.5	3	3.5	4.5	5.5													
Length/dim	M3	M4	M5	M6	M8	M10													
	■	■	■	■	■	■													

[CLICK HERE TO RETURN TO THE CONTENTS PAGE](#)

+ 37 064 411 786

Inquiry@invayear.com

www.invayear.com

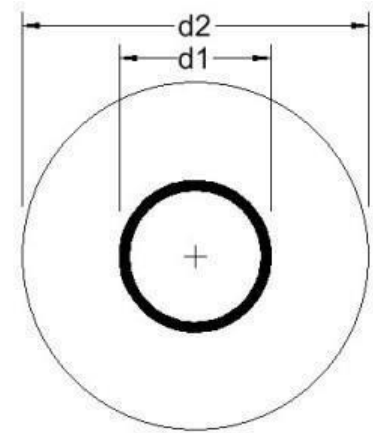
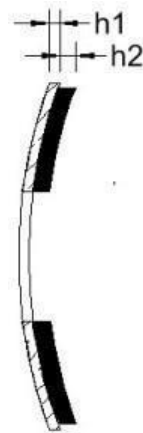
WASHERS
BONDED SEALING WASHERS WITH GREY EPDM

Material grades: A2:■

h1	0.8	0.8	0.8	0.8	0.8	0.8	0.8	0.8	0.8								
h2	2	2	2	2	2	2	2	2	2								
Length/dim	4.8	5.2	5.3	6.2	6.7	6.8	8.4	10.5	13.0								
12	■		■														
14	■	■	■														
16			■	■	■	■	■										
19			■		■	■	■										
22					■	■	■										
25					■	■	■	■									
29					■		■	■	■								

[CLICK HERE TO RETURN TO THE CONTENTS PAGE](#)

+ 37 064 411 786

Inquiry@invayear.com

www.invayear.com

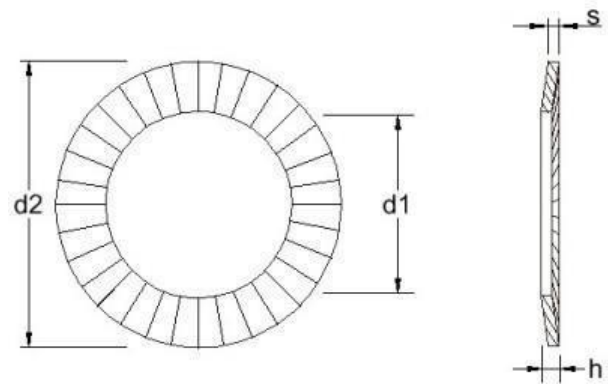
AFNOR SERRATED CONICAL SPRING WASHERS TYPE M (NF E 25-511)

Material grades: A2: ■ A4: ◆

d1 (Max)	3.35	4.4	5.4	6.4	8.58	10.56	12.83	14.83	16.83	21.02							
d2	8	10	12	14	18	22	27	30	32	40							
h (Max)	1.0	1.4	1.8	2.1	2.35	2.75	3.1	3.7	4.1	4.9							
s	0.6	0.9	1.1	1.3	1.4	1.6	1.8	2.4	2.8	3.2							
Length/dim	M3	M4	M5	M6	M8	M10	M12	M14	M16	M20							
	■◆	■◆	■◆	■◆	■◆	■◆	■◆	■◆	■◆	■◆							

[CLICK HERE TO RETURN TO THE CONTENTS PAGE](#)



+ 37 064 411 786



Inquiry@invayear.com



www.invayear.com

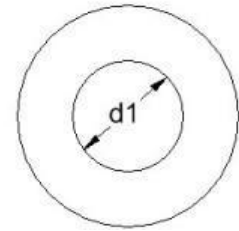
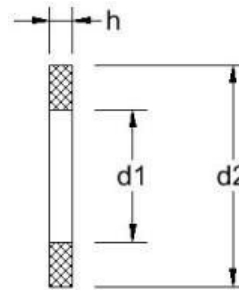

Material grades: A2: ■ A4: ◆

d1 (Min)	2.2	2.7	3.2	4.3	5.3	6.4	8.4	10.5	13	17	21						
d2 (Max)	4	5	6	8	10	12	16	20	24	30	36						
h	0.5	0.5	0.8	0.8	1	1.2	1.5	2	2.5	3	3						
Length/dim	M2	M2.5	M3	M4	M5	M6	M8	M10	M12	M16	M20						
	■ ◆	■ ◆	■ ◆	■ ◆	■ ◆	■ ◆	■ ◆	■ ◆	■ ◆	■ ◆	■ ◆						

[CLICK HERE TO RETURN TO THE CONTENTS PAGE](#)



+ 37 064 411 786

Inquiry@invayear.com

www.invayear.com

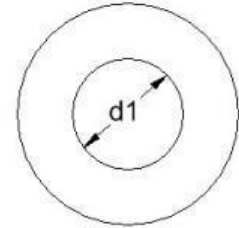
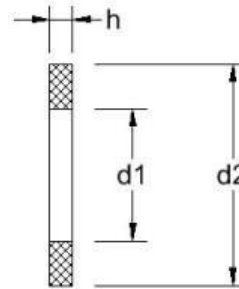
AFNOR FLAT WASHERS (NF E 25-514) TYPE M

Material grades: A2: ■ A4: ◆

d1 (Min)	2.2	2.7	3.2	4.3	5.3	6.4	8.4	10.5	13	15	17	19	21	23	25	28	31
d2 (Max)	5.5	7	8	10	12	14	18	22	27	30	32	36	40	45	50	55	60
h	0.5	0.5	0.8	0.8	1.0	1.2	1.5	2.0	2.5	2.5	3	3	3	3	4	4	4
Length/dim	M2	M2.5	M3	M4	M5	M6	M8	M10	M12	M14	M16	M18	M20	M22	M24	M27	M30
	■◆	■◆	■◆	■◆	■◆	■◆	■◆	■◆	■◆	■◆	■◆	■◆	■◆	■◆	■◆	■◆	■◆

d1 (Min)	34	37															
d2 (Max)	65	70															
h	5	5															
Length/dim	M33	M36															
	■◆	■◆															

[CLICK HERE TO RETURN TO THE CONTENTS PAGE](#)



+ 37 064 411 786



Inquiry@invayear.com



www.invayear.com

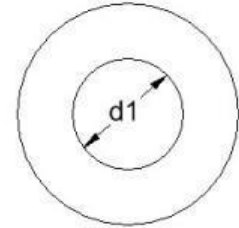
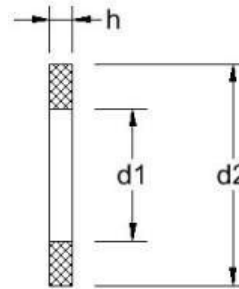

Material grades: A2: ■ A4: ◆

d1 (Min)	3.2	4.3	5.3	6.4	8.4	10.5	13	15	17	19	21								
d2 (Max)	12	14	16	18	22	27	32	36	40	45	50								
h	0.8	0.8	1.0	1.2	1.5	2.0	2.5	2.5	3.0	3.0	3.0								
Length/dim	M3	M4	M5	M6	M8	M10	M12	M14	M16	M18	M20								
	■◆	■◆	■◆	■◆	■◆	■◆	■◆	■◆	■◆	■◆	■◆								

[CLICK HERE TO RETURN TO THE CONTENTS PAGE](#)



+ 37 064 411 786

Inquiry@invayear.com

www.invayear.com

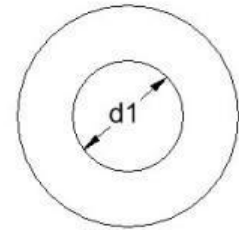
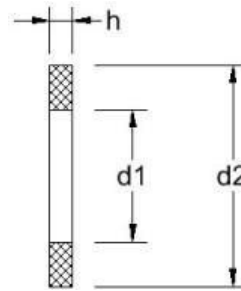
AFNOR FLAT WASHERS (NF E 25-514) TYPE LL

Material grades: A2: ■ A4: ◆

d1 (Min)	3.2	4.3	5.3	6.4	8.4	10.5	13	17										
d2 (Max)	14	16	20	24	30	36	40	50										
h	0.5	0.8	1	1.2	1.5	2.0	2.5	3										
Length/dim	M3	M4	M5	M6	M8	M10	M12	M16										
	■ ◆	■ ◆	■ ◆	■ ◆	■ ◆	■ ◆	■ ◆	■ ◆										

[CLICK HERE TO RETURN TO THE CONTENTS PAGE](#)



+ 37 064 411 786

Inquiry@invayear.com

www.invayear.com

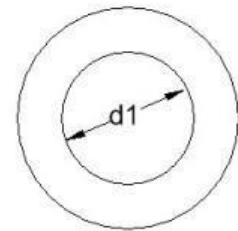
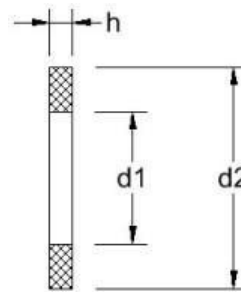

Material grades: A2: ■ A4: ◆

d1	0.078	0.099	0.109	0.125	0.140	0.149	0.174	0.203	0.250	0.281	0.343	0.406	0.500	0.531	0.687	0.812	0.937	
d2	0.187	0.250	0.250	0.312	0.438	0.375	0.375	0.437	0.562	0.625	0.750	0.875	1.125	1.250	1.500	1.875	2.00	
h	0.020	0.031	0.031	0.031	0.046	0.031	0.031	0.063	0.050	0.050	0.050	0.050	0.062	0.062	0.078	0.109	0.109	
Length/dim	#0	#2	#3	#4	#5	#6	#8	#10	#12	1/4	5/16	3/8	7/16	1/2	5/8	3/4	7/8	
	■	■	■	◆	■	◆	◆	◆	◆	◆	◆	◆	◆	◆	◆	◆	◆	◆

d1	1.062	1.187	1.312	1.500	1.562	1.812	2.125										
d2	2.00	2.50	2.75	3.25	3.25	3.50	4.00										
h	0.125	0.125	0.125	0.140	0.140	0.140	0.187										
Length/dim	1	1.1/8	1.1/4	1.3/8	1.1/2	1.3/4	2										
	◆	◆	◆	◆	◆	◆	◆										

[CLICK HERE TO RETURN TO THE CONTENTS PAGE](#)



+ 37 064 411 786



Inquiry@invayear.com

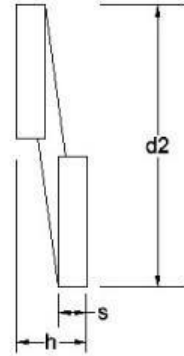
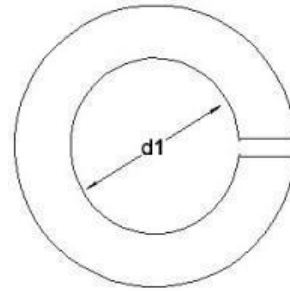

www.invayear.com

USA SPRING WASHERS ANSI B18.21.1

Material grades: A2: ■ A4: ◆

d1 (Min)	0.062	0.075	0.088	0.101	0.114	0.127	0.141	0.167	0.193	0.220	0.252	0.314	0.377	0.440	0.502		0.628	
d2 (Max)	0.137	0.150	0.172	0.195	0.209	0.236	0.250	0.293	0.334	0.377	0.487	0.583	0.680	0.776	0.869		1.072	
h (Min)	0.020	0.022	0.035	0.040	0.040	0.047	0.047	0.055	0.062	0.070	0.109	0.125	0.141	0.156	0.171		0.203	
s (Min)	0.017	0.020	0.020	0.025	0.025	0.031	0.031	0.040	0.047	0.056	0.062	0.078	0.094	0.109	0.125		0.156	
Length/dim	#0	#1	#2	#3	#4	#5	#6	#8	#10	#12	1/4	5/16	3/8	7/16	1/2	9/16	5/8	
	■	■	■◆	■◆	■◆	■◆	■◆	■◆	■◆	■◆	■◆	■◆	■◆	■◆	■◆	■◆	■◆	■◆

d1 (Min)	0.753	0.878	1.003	1.129	1.254	1.379	1.504										
d2 (Max)	1.264	1.455	1.647	1.838	2.028	2.210	2.409										
h (Min)	0.234	0.266	0.297	0.328	0.359	0.391	0.422										
s (Min)	0.188	0.219	0.250	0.281	0.312	0.344	0.375										
Length/dim	3/4	7/8	1	1.1/8	1.1/4	1.3/8	1.1/2										
	■◆	■◆	■◆	■◆	■◆	■◆	■◆										

[CLICK HERE TO RETURN TO THE CONTENTS PAGE](#)



+ 37 064 411 786



Inquiry@invayear.com



www.invayear.com

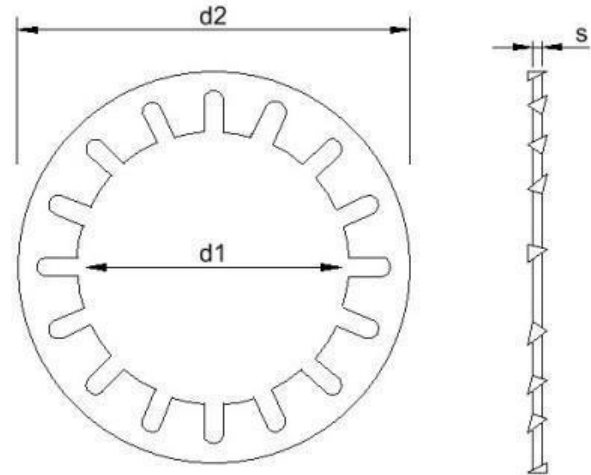

Material grades: A2: ■

d1 (Min)	0.089	0.102	0.115	0.141	0.168	0.195	0.221	0.256	0.320	0.384	0.448	0.512		0.640	0.769	0.894	1.019
d2 (Max)	0.200	0.232	0.270	0.295	0.340	0.381	0.410	0.478	0.610	0.692	0.789	0.900		1.071	1.245	1.410	1.637
s (Max)	0.016	0.016	0.018	0.022	0.023	0.024	0.027	0.028	0.034	0.040	0.040	0.045		0.050	0.055	0.060	0.067
Length/dim	#2	#3	#4	#6	#8	#10	#12	1/4	5/16	3/8	7/16	1/2	9/16	5/8	3/4	7/8	1
	■	■	■	■	■	■	■	■	■	■	■	■	■	■	■	■	■

[CLICK HERE TO RETURN TO THE CONTENTS PAGE](#)



+ 37 064 411 786

Inquiry@invayear.com

www.invayear.com

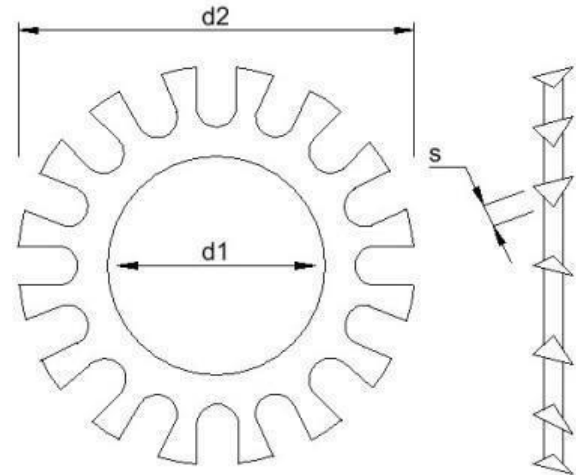
USA EXTERNAL TOOTH WASHERS ANSI B18.21.1

Material grades: A2: ■

d1 (Min)	*	0.102	0.115	0.141	0.168	0.195	0.221	0.256	0.320	0.384	0.448	0.513		0.641	0.768	0.897	1.025	
d2 (Max)	*	0.235	0.260	0.320	0.381	0.410	0.475	0.510	0.610	0.694	0.760	0.900		1.070	1.260	1.410	1.620	
s (Max)	*	0.016	0.018	0.022	0.023	0.024	0.027	0.028	0.034	0.040	0.040	0.045		0.050	0.055	0.060	0.067	
Length/dim		#2	#3	#4	#6	#8	#10	#12	1/4	5/16	3/8	7/16	1/2	9/16	5/8	3/4	7/8	1
		■	■	■	■	■	■	■	■	■	■	■	■	■	■	■	■	■

[CLICK HERE TO RETURN TO THE CONTENTS PAGE](#)



+ 37 064 411 786

Inquiry@invayear.com

www.invayear.com

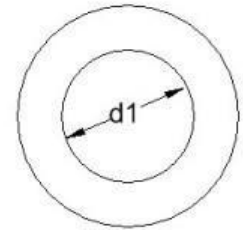
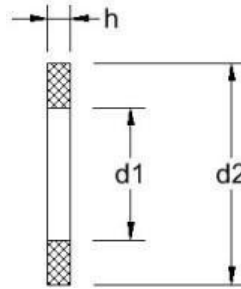
WASHERS
USA 800 SERIES FLAT WASHERS

Material grades: A2:■

d1	0.078	0.093	0.125	0.125	0.156	0.156	0.187	0.218	0.188	0.219	0.250	0.281	0.343	0.312	0.406	0.375	0.468
Thickness/d2	0.187	0.250	0.250	0.312	0.312	0.375	0.375	0.437	0.438	0.500	0.562	0.625	0.687	0.750	0.812	0.875	0.921
0.0200	■	■															
0.0220			■														
0.0320				■													
0.0370					■												
0.0510						■	■	■	■	■							
0.0650											■	■	■	■	■		■
0.0840																■	
0.0980																	
0.1090																	
0.1340																	
0.1500																	
0.1640																	

d1	0.437	0.531	0.500	0.656	0.562	0.812	0.687	0.937	0.812	1.062	0.937	1.062					
Thickness/d2	1.000	1.062	1.250	1.312	1.375	1.500	1.750	1.750	2.000	2.000	2.250	2.500					
0.0200																	
0.0220																	
0.0320																	
0.0370																	
0.0510																	
0.0650																	
0.0840	■		■														
0.0980		■		■													
0.1090					■												
0.1340						■	■	■		■							
0.1500									■								
0.1640											■	■					

[CLICK HERE TO RETURN TO THE CONTENTS PAGE](#)



+ 37 064 411 786



Inquiry@invayear.com

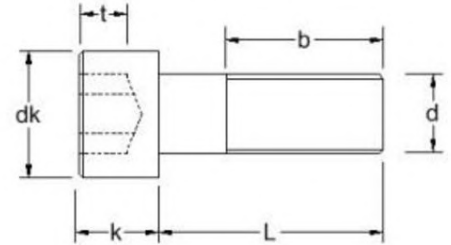

www.invayear.com

SOCKET CAP SCREWS DIN 912

Material grades: A2:■ A4:◆ A4-80:★

	14.8	15	16	17	18	20	20	22	24	28	32	36	40	44	48	52	56
b (Max)	14.8	15	16	17	18	20	20	22	24	28	32	36	40	44	48	52	56
dk	2.6	3.0	3.8	4.5	5.5	6.0	7.0	8.5	10	13	16	18	21	24	27	30	33
k (Max)	1.4	1.6	2.0	2.5	3	3.5	4	5	6	8	10	12	14	16	18	20	22
Pitch	0.3	0.35	0.4	0.45	0.5	0.6	0.7	0.8	1.0	1.25	1.5	1.75	2.0	2.0	2.5	2.5	2.5
s	1.3	1.5	1.5	2	2.5	2.5	3	4	5	6	8	10	12	14	14	17	17
t (Min)	0.6	0.7	1.0	1.1	1.3	1.6	2.0	2.5	3	4	5	6	7	8	9	10	11
Length/dim	M1.4	M1.6	M2	M2.5	M3	M3.5	M4	M5	M6	M8	M10	M12	M14	M16	M18	M20	M22
2	■◆																
3	■◆	■◆	■◆	■◆	■◆												
4	■◆	■◆	■◆	■◆	■◆		■◆★										
5	■◆	■◆	■◆	■◆	■◆	■◆	■◆★	■◆★									
6	■◆	■◆	■◆	■◆	■◆	■◆	■◆★	■◆★	■◆★								
7			■														
8	■◆	■◆	■◆	■◆	■◆	■◆	■◆★	■◆★	■◆★	■◆★							
10	■◆	■◆	■◆	■◆	■◆	■◆	■◆★	■◆★	■◆★	■◆★	■◆★						
12	■◆	■◆	■◆	■◆	■◆	■◆	■◆★	■◆★	■◆★	■◆★	■◆★	■◆★	■◆★				
14		■◆	■◆	■◆	■◆		■◆★	■◆★	■◆★	■◆★	■◆★	■◆★	■◆★				
16	■◆	■◆	■◆	■◆	■◆	■◆	■◆★	■◆★	■◆★	■◆★	■◆★	■◆★	■◆★	■◆★			
18		■◆	■	■◆	■		■◆★	■◆★	■◆★	■◆★	■◆★	■◆★	■◆★	■◆			
20		■◆	■◆	■◆	■◆	■◆	■◆★	■◆★	■◆★	■◆★	■◆★	■◆★	■◆★	■◆★	■◆	■◆★	
22			■◆	■◆	■◆		■◆★	■◆★	■◆★	■◆★	■◆★	■◆★	■◆★	■◆			

CLICK HERE TO RETURN TO THE CONTENTS PAGE



+ 37 064 411 786



Inquiry@invayear.com



www.invayear.com

SOCKET CAP SCREWS DIN 912

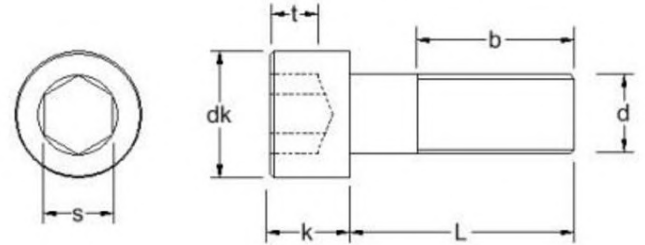

Material grades: A2: ■ A4: ◆ A4-80: *

Length/dim	M1.4	M1.6	M2	M2.5	M3	M3.5	M4	M5	M6	M8	M10	M12	M14	M16	M18	M20	M22
b (Max)	14.8	15	16	17	18	20	20	22	24	28	32	36	40	44	48	52	56
dk	2.6	3.0	3.8	4.5	5.5	6.0	7.0	8.5	10	13	16	18	21	24	27	30	33
k (Max)	1.4	1.6	2.0	2.5	3	3.5	4	5	6	8	10	12	14	16	18	20	22
Pitch	0.3	0.35	0.4	0.45	0.5	0.6	0.7	0.8	1.0	1.25	1.5	1.75	2.0	2.0	2.5	2.5	2.5
s	1.3	1.5	1.5	2	2.5	2.5	3	4	5	6	8	10	12	14	14	17	17
τ (Min)	0.6	0.7	1.0	1.1	1.3	1.6	2.0	2.5	3	4	5	6	7	8	9	10	11
25			◆	◆	◆	◆	◆	◆*	◆*	◆*	◆*	◆*	◆*	◆*	◆*		
30/30								◆									
30			◆	■	◆	◆	◆*	◆*	◆*	◆*	◆*	◆*	◆*	◆*	◆*	◆	◆*
35/35							◆	◆	◆								
35			◆	◆			◆*	◆*	◆*	◆*	◆*	◆*	◆*	◆*	◆*	◆	◆*
40/40							◆	◆	◆	◆	◆						
40			◆	◆			◆*	◆*	◆*	◆*	◆*	◆*	◆*	◆*	◆*	◆	◆*
45/45								◆	◆	◆	◆						
45				◆			◆*	◆*	◆*	◆*	◆*	◆*	◆*	◆*	◆*	◆	◆*
50/50								◆	◆	◆	◆						
50				◆			◆*	◆*	◆*	◆*	◆*	◆*	◆*	◆*	◆*	◆	◆*
55/55								◆	◆	◆	◆						
55				◆			◆*	◆*	◆*	◆*	◆*	◆*	◆*	◆*	◆*	◆	◆*
60				◆			◆*	◆*	◆*	◆*	◆*	◆*	◆*	◆*	◆*	◆	◆*

CLICK HERE TO RETURN TO THE CONTENTS PAGE



+ 37 064 411 786



Inquiry@invayear.com

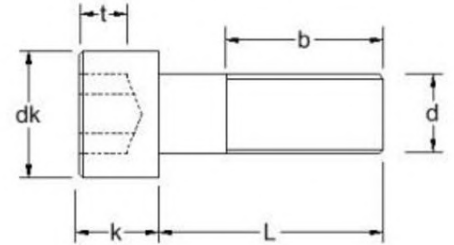

www.invayear.com

SOCKET CAP SCREWS DIN 912

Material grades: A2: ■ A4: ◆ A4-80: *

Length/dim	M24	M27	M30																
b (Max)	60	66	72																
dk	36	40	45																
k (Max)	24	27	30																
Pitch	3.0	3.0	3.5																
s	19	19	22																
t (Min)	12	13.5	15.5																
25																			
30/30																			
30																			
35/35																			
35																			
40/40																			
40	■ ◆ *																		
45/45																			
45	■ ◆ *																		
50/50																			
50	■ ◆ *	■ ◆	■ ◆																
55/55																			
55	■ ◆ *	■ ◆	■ ◆																
60	■ ◆ *	■ ◆	■ ◆																

CLICK HERE TO RETURN TO THE CONTENTS PAGE



+ 37 064 411 786



Inquiry@invayear.com



www.invayear.com

SOCKET CAP SCREWS DIN 912

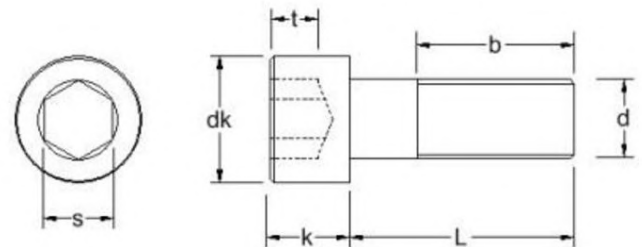

Material grades: A2:■ A4:◆ A4-80:★

b (Max)	14.8	15	16	17	18	20	20	22	24	28	32	36	40	44	48	52	56
dk	2.6	3.0	3.8	4.5	5.5	6.0	7.0	8.5	10	13	16	18	21	24	27	30	33
k (Max)	1.4	1.6	2.0	2.5	3	3.5	4	5	6	8	10	12	14	16	18	20	22
Pitch	0.3	0.35	0.4	0.45	0.5	0.6	0.7	0.8	1.0	1.25	1.5	1.75	2.0	2.0	2.5	2.5	2.5
s	1.3	1.5	1.5	2	2.5	2.5	3	4	5	6	8	10	12	14	14	17	17
t (Min)	0.6	0.7	1.0	1.1	1.3	1.6	2.0	2.5	3	4	5	6	7	8	9	10	11
Length/dim	M1.4	M1.6	M2	M2.5	M3	M3.5	M4	M5	M6	M8	M10	M12	M14	M16	M18	M20	M22
60/60								◆	◆	◆	◆						
65					◆		◆	◆	◆	◆	◆	◆	◆	◆	◆	◆	◆
70					◆		◆	◆	◆	◆	◆	◆	◆	◆	◆	◆	◆
70/70								◆	◆	◆	◆						
75							◆	◆	◆	◆	◆	◆	◆	◆	◆	◆	◆
80/80									◆	◆	◆						
80							◆	◆	◆	◆	◆	◆	◆	◆	◆	◆	◆
85								◆	◆	◆	◆	◆	◆	◆	◆	◆	◆
90/90									◆	◆	◆						
90							◆	◆	◆	◆	◆	◆	◆	◆	◆	◆	◆
95								◆	◆	◆	◆	◆	◆	◆	◆	◆	◆
100/100									◆	◆	◆						
100							◆	◆	◆	◆	◆	◆	◆	◆	◆	◆	◆
110								◆	◆	◆	◆	◆	◆	◆	◆	◆	◆

CLICK HERE TO RETURN TO THE CONTENTS PAGE



+ 37 064 411 786



Inquiry@invayear.com

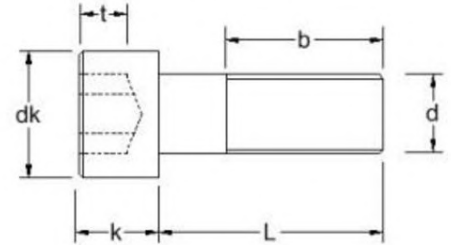

www.invayear.com

SOCKET CAP SCREWS DIN 912

Material grades: A2: ■ A4: ◆ A4-80: *

Length/dim	M24	M27	M30												
b (Max)	60	66	72												
dk	36	40	45												
k (Max)	24	27	30												
Pitch	3.0	3.0	3.5												
s	19	19	22												
τ (Min)	12	13.5	15.5												
60/60															
65	■ ◆ *	■ ◆	■ ◆												
70	■ ◆ *	■ ◆	■ ◆												
70/70															
75	■ ◆ *	■ ◆	■ ◆												
80/80															
80	■ ◆ *	■ ◆	■ ◆												
85	◆	■ ◆	■ ◆												
90/90															
90	■ ◆ *	■ ◆	■ ◆												
95	◆	■ ◆	■ ◆												
100/100															
100	■ ◆ *	■ ◆	■ ◆												
110	■ ◆ *	■ ◆	■ ◆												

CLICK HERE TO RETURN TO THE CONTENTS PAGE



+ 37 064 411 786



Inquiry@invayear.com



www.invayear.com

SOCKET CAP SCREWS DIN 912

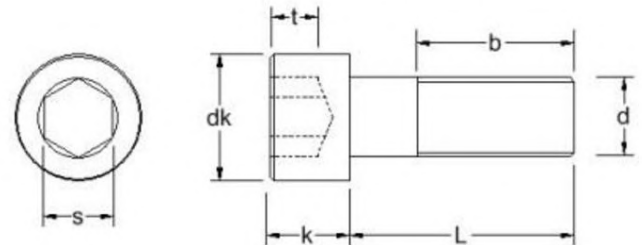

Material grades: A2: ■ A4: ◆ A4-80: *

b (Max)	14.8	15	16	17	18	20	20	22	24	28	32	36	40	44	48	52	56
dk	2.6	3.0	3.8	4.5	5.5	6.0	7.0	8.5	10	13	16	18	21	24	27	30	33
k (Max)	1.4	1.6	2.0	2.5	3	3.5	4	5	6	8	10	12	14	16	18	20	22
Pitch	0.3	0.35	0.4	0.45	0.5	0.6	0.7	0.8	1.0	1.25	1.5	1.75	2.0	2.0	2.5	2.5	2.5
s	1.3	1.5	1.5	2	2.5	2.5	3	4	5	6	8	10	12	14	14	17	17
τ (Min)	0.6	0.7	1.0	1.1	1.3	1.6	2.0	2.5	3	4	5	6	7	8	9	10	11
Length/dim	M1.4	M1.6	M2	M2.5	M3	M3.5	M4	M5	M6	M8	M10	M12	M14	M16	M18	M20	M22
120								◆	◆*	◆	◆*	◆*	◆*	◆*	◆	◆*	◆
130								◆	◆*	◆	◆*	◆*	◆*	◆*	◆	◆*	◆
140								◆	◆*	◆	◆*	◆*	◆*	◆*	◆	◆*	◆
150									◆*	◆	◆*	◆*	◆*	◆*	◆	◆*	◆
160									◆	◆	◆*	◆*	◆	◆			◆
170										◆	◆	◆	◆	◆			◆
180									◆	◆	◆	◆	◆	◆			◆
190									◆		◆	◆	◆				◆
200									◆	◆	◆	◆	◆	◆			◆
210										◆	◆	◆					
220										◆	◆	◆					
230										◆	◆	◆					
240										◆	◆	◆					
250										◆	◆	◆					

[CLICK HERE TO RETURN TO THE CONTENTS PAGE](#)



+ 37 064 411 786



Inquiry@invayear.com



www.invayear.com

SOCKET CAP SCREWS DIN 912

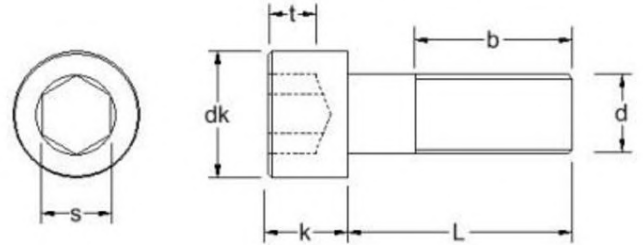

Material grades: A2: ■ A4: ◆ A4-80: *

	M24	M27	M30												
b (Max)	60	66	72												
dk	36	40	45												
k (Max)	24	27	30												
Pitch	3.0	3.0	3.5												
s	19	19	22												
τ (Min)	12	13.5	15.5												
Length/dim	M24	M27	M30												
120	■ ◆ *	■ ◆	■ ◆												
130	■ ◆ *	■ ◆	■ ◆												
140	■ ◆ *	■ ◆	■ ◆												
150	■ ◆ *	■ ◆	■ ◆												
160	■ ◆	■ ◆	■ ◆												
170	■ ◆	■ ◆	■ ◆												
180	■ ◆	■ ◆	■ ◆												
190	■ ◆	■ ◆	■ ◆												
200	■ ◆	■ ◆	■ ◆												
210	■ ◆														
220	■ ◆														
230	■ ◆														
240	■ ◆														
250	■ ◆														

[CLICK HERE TO RETURN TO THE CONTENTS PAGE](#)



+ 37 064 411 786



Inquiry@invayear.com

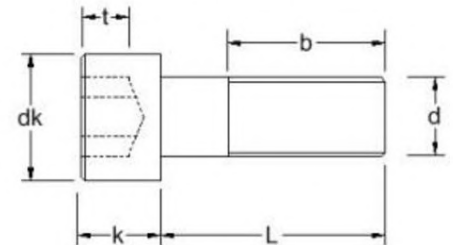

www.invayear.com

SOCKET CAP SCREWS DIN 912

Material grades: A2: ■ A4: ◆

b (Max)	14.8	15	16	17	18	20	20	22	24	28	32	36	40	44	48	52	56
dk	2.6	3.0	3.8	4.5	5.5	6.0	7.0	8.5	10	13	16	18	21	24	27	30	33
k (Max)	1.4	1.6	2.0	2.5	3	3.5	4	5	6	8	10	12	14	16	18	20	22
Pitch	0.3	0.35	0.4	0.45	0.5	0.6	0.7	0.8	1.0	1.25	1.5	1.75	2.0	2.0	2.5	2.5	2.5
s	1.3	1.5	1.5	2	2.5	2.5	3	4	5	6	8	10	12	14	14	17	17
t (Min)	0.6	0.7	1.0	1.1	1.3	1.6	2.0	2.5	3	4	5	6	7	8	9	10	11
Length/dim	M1.4	M1.6	M2	M2.5	M3	M3.5	M4	M5	M6	M8	M10	M12	M14	M16	M18	M20	M22
260										■	◆	◆					
270										◆	◆	◆					
280										■	◆	◆					
290										◆	◆	◆					
300										■	◆	◆					

b (Max)	60	66	72														
dk	36	40	45														
k (Max)	24	27	30														
Pitch	3.0	3.0	3.5														
s	19	19	22														
t (Min)	12	13.5	15.5														
Length/dim	M24	M27	M30														
260	◆																
270	◆																
280	◆																
290	◆																
300	◆																

CLICK HERE TO RETURN TO THE CONTENTS PAGE



+ 37 064 411 786



Inquiry@invayear.com

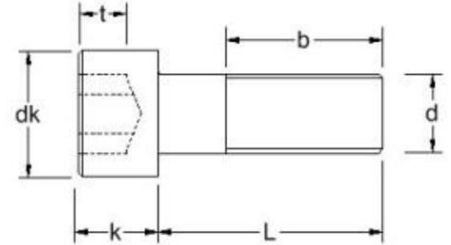

www.invayear.com

TX CAP SCREWS ISO 14579

 Material grades: **A2**

b (Max) = L	16	17	18	20	22	24	28											
dk	3.8	4.5	5.5	7.0	8.5	10	13											
k (Max)	2.0	2.5	3	4	5	6	8											
Pitch	0.4	0.45	0.5	0.7	0.8	1.0	1.25											
τ (Min)	1.0	1.1	1.3	2.0	2.5	3	4											
Length/dim	M2	M2.5	M3	M4	M5	M6	M8											
3	■	■																
4	■	■	■															
5	■	■	■	■														
6	■	■	■	■	■	■												
8	■	■	■	■	■	■												
10	■	■	■	■	■	■												
12	■	■	■	■	■	■												
14	■	■	■	■	■	■												
16	■	■	■	■	■	■	■											
18	■	■	■	■	■	■	■											
20	■	■	■	■	■	■	■											
22			■	■	■	■	■											
25			■	■	■	■	■											
30			■	■	■	■	■											
35				■	■	■	■											
40				■	■	■	■											
45				■	■	■	■											
50				■	■	■	■											
60				■	■	■	■											

CLICK HERE TO RETURN TO THE CONTENTS PAGE



+ 37 064 411 786



Inquiry@invayear.com

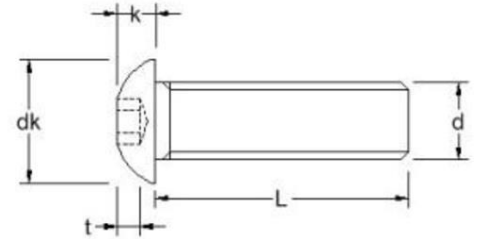

www.invayear.com

SOCKET BUTTON SCREWS ISO 7380-1

Material grades: A2: ■ A4: ◆

dk(Max)	3.5	4.5	5.7	6.6	7.6	9.5	10.5	14	17.5	21						
k (Max)	1.3	1.5	1.65	1.9	2.2	2.75	3.3	4.4	5.5	6.6						
Pitch	0.4	0.45	0.5	0.6	0.7	0.8	1.0	1.25	1.5	1.75						
s	1.3	1.5	2	2	2.5	3	4	5	6	8						
t (Min)	0.8	1.0	1.04	1.2	1.3	1.56	2.08	2.60	3.12	4.16						
Length/dim	M2	M2.5	M3	M3.5	M4	M5	M6	M8	M10	M12						
3	■◆	■◆	■◆													
4	■◆	■◆	■◆		■◆											
5	■◆	■◆	■◆	■◆	■◆	■◆										
6	■◆	■◆	■◆	■◆	■◆	■◆	■◆									
8	■◆	■◆	■◆	■◆	■◆	■◆	■◆	■◆								
9			■													
10	■◆	■◆	■◆	■◆	■◆	■◆	■◆	■◆								
12	■◆	■◆	■◆	■◆	■◆	■◆	■◆	■◆	■◆							
14			■◆		■◆	■◆	■◆	■◆	■◆							
16	■◆	■◆	■◆	■◆	■◆	■◆	■◆	■◆	■◆	■◆						
18			■◆		■◆	■◆	■◆	■◆	■◆	■◆						
20	■◆	■◆	■◆	■◆	■◆	■◆	■◆	■◆	■◆	■◆	■◆					
22			■◆		■◆	■◆	■◆	■◆	■◆	■◆	◆					
25			■◆	■◆	■◆	■◆	■◆	■◆	■◆	■◆	■◆					
30			■◆	■◆	■◆	■◆	■◆	■◆	■◆	■◆	■◆					

[CLICK HERE TO RETURN TO THE CONTENTS PAGE](#)



+ 37 064 411 786



Inquiry@invayear.com

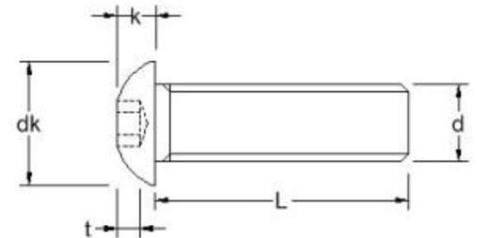

www.invayear.com

SOCKET BUTTON SCREWS ISO 7380-1

Material grades: A2: ■ A4: ◆

dk(Max)	3.5	4.5	5.7	6.6	7.6	9.5	10.5	14	17.5	21									
k (Max)	1.3	1.5	1.65	1.9	2.2	2.75	3.3	4.4	5.5	6.6									
Pitch	0.4	0.45	0.5	0.6	0.7	0.8	1.0	1.25	1.5	1.75									
s	1.3	1.5	2	2	2.5	3	4	5	6	8									
τ (Min)	0.8	1.0	1.04	1.2	1.3	1.56	2.08	2.60	3.12	4.16									
Length/dim	M2	M2.5	M3	M3.5	M4	M5	M6	M8	M10	M12									
35			■ ◆		■ ◆	■ ◆	■ ◆	■ ◆	■ ◆	■ ◆									
40			■ ◆		■ ◆	■ ◆	■ ◆	■ ◆	■ ◆	■ ◆									
45			■ ◆		■ ◆	■ ◆	■ ◆	■ ◆	■ ◆	■ ◆									
50			■ ◆		■ ◆	■ ◆	■ ◆	■ ◆	■ ◆	■ ◆									
55					■ ◆	■ ◆	■ ◆	■ ◆	■ ◆	■ ◆									
60					■ ◆	■ ◆	■ ◆	■ ◆	■ ◆	■ ◆									
65						■ ◆	■ ◆	■ ◆	■ ◆	■ ◆									
70						■ ◆	■ ◆	■ ◆	■ ◆	■ ◆									
75						■ ◆	■ ◆	■ ◆	■ ◆	■ ◆									
80						■ ◆	■ ◆	■ ◆	■ ◆	■ ◆									
90							■ ◆	■ ◆	■ ◆	■ ◆									
100							■ ◆	■ ◆	■ ◆	■ ◆									
110							■ ◆	■ ◆	■ ◆	■ ◆									
120							■ ◆	■ ◆	■ ◆	■ ◆									

CLICK HERE TO RETURN TO THE CONTENTS PAGE



+ 37 064 411 786



Inquiry@invayear.com

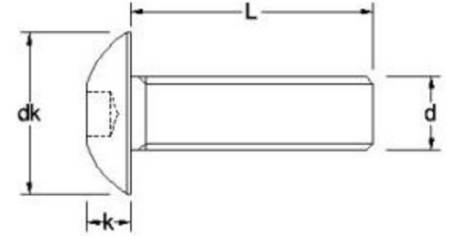
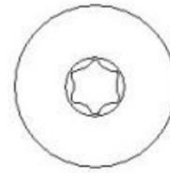

www.invayear.com

TX BUTTON SCREWS ISO 7380-1

 Material grades: **A2:** ■

dk(Max)	5.7	7.6	9.5	10.5	14	17.5	21											
k (Max)	1.65	2.2	2.75	3.3	4.4	5.5	6.6											
Pitch	0.5	0.7	0.8	1.0	1.25	1.5	1.75											
Length/dim	M3	M4	M5	M6	M8	M10	M12											
3	■																	
4	■	■																
5	■	■	■															
6	■	■	■	■														
8	■	■	■	■	■													
10	■	■	■	■	■	■												
12	■	■	■	■	■	■	■											
14	■	■	■	■	■	■	■											
16	■	■	■	■	■	■	■	■										
18	■	■	■	■	■	■	■	■	■									
20	■	■	■	■	■	■	■	■	■									
22	■	■	■	■	■	■	■	■	■	■								
25	■	■	■	■	■	■	■	■	■	■								
30	■	■	■	■	■	■	■	■	■	■	■							
35	■	■	■	■	■	■	■	■	■	■	■	■						
40	■	■	■	■	■	■	■	■	■	■	■	■	■					
45	■	■	■	■	■	■	■	■	■	■	■	■	■	■				

[CLICK HERE TO RETURN TO THE CONTENTS PAGE](#)



+ 37 064 411 786



Inquiry@invayear.com

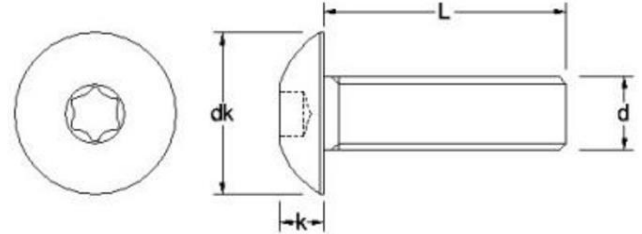

www.invayear.com

 Material grades: **A2**: ■

dk(Max)	5.7	7.6	9.5	10.5	14	17.5	21												
k (Max)	1.65	2.2	2.75	3.3	4.4	5.5	6.6												
Pitch	0.5	0.7	0.8	1.0	1.25	1.5	1.75												
Length/dim	M3	M4	M5	M6	M8	M10	M12												
50	■	■	■	■	■	■	■												
55		■	■	■	■	■	■												
60		■	■	■	■	■	■												
65			■	■	■	■	■												
70			■	■	■	■	■												
75			■	■	■	■	■												
80			■	■	■	■	■												
90				■	■	■	■												
100				■	■	■	■												
110				■	■	■	■												
120				■	■	■	■												

CLICK HERE TO RETURN TO THE CONTENTS PAGE



+ 37 064 411 786



Inquiry@invayear.com

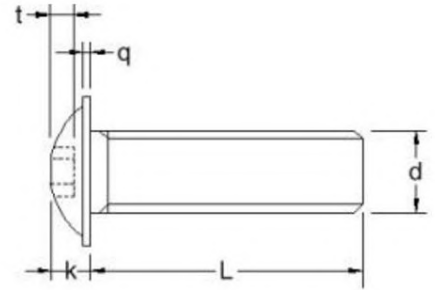
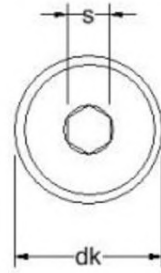

www.invayear.com

FLANGED SOCKET BUTTONS ISO 7380-2

Material grades: A2: ■ A4: ◆

dk (Max)	6.9	9.4	11.8	13.6	17.8	21.9	26											
k	1.65	2.2	2.75	3.3	4.4	5.5	6.6											
Pitch	0.5	0.7	0.8	1.0	1.25	1.5	1.75											
q	0.7	0.8	0.9	1.2	1.5	2.0	2.4											
s	2	2.5	3	4	5	6	8											
t (Min)	1.04	1.3	1.56	2.08	2.6	3.12	4.16											
Length/dim	M3	M4	M5	M6	M8	M10	M12											
3	■ ◆																	
4	■ ◆	■ ◆																
5	■ ◆	■ ◆	■ ◆															
6	■ ◆	■ ◆	■ ◆	■ ◆														
8	■ ◆	■ ◆	■ ◆	■ ◆	■ ◆													
10	■ ◆	■ ◆	■ ◆	■ ◆	■ ◆	■ ◆												
12	■ ◆	■ ◆	■ ◆	■ ◆	■ ◆	■ ◆	■ ◆											
14	■ ◆	■ ◆	■ ◆	■ ◆	■ ◆	■ ◆	■ ◆											
16	■ ◆	■ ◆	■ ◆	■ ◆	■ ◆	■ ◆	■ ◆	■ ◆										
18	■ ◆	■ ◆	■ ◆	■ ◆	■ ◆	■ ◆	■ ◆	■ ◆										
20	■ ◆	■ ◆	■ ◆	■ ◆	■ ◆	■ ◆	■ ◆	■ ◆										
22	■ ◆	■ ◆	■ ◆	■ ◆	■ ◆	■ ◆	■ ◆	■ ◆										
25	■ ◆	■ ◆	■ ◆	■ ◆	■ ◆	■ ◆	■ ◆	■ ◆										
30	■ ◆	■ ◆	■ ◆	■ ◆	■ ◆	■ ◆	■ ◆	■ ◆										

CLICK HERE TO RETURN TO THE CONTENTS PAGE



+ 37 064 411 786



Inquiry@invayear.com

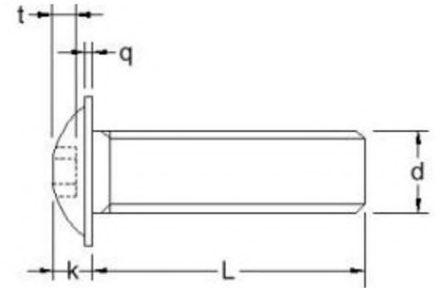
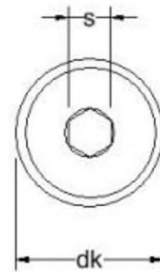

www.invayear.com

FLANGED SOCKET BUTTONS ISO 7380-2

Material grades: A2: ■ A4: ◆

dk (Max)	6.9	9.4	11.8	13.6	17.8	21.9	26										
k	1.65	2.2	2.75	3.3	4.4	5.5	6.6										
Pitch	0.5	0.7	0.8	1.0	1.25	1.5	1.75										
q	0.7	0.8	0.9	1.2	1.5	2.0	2.4										
s	2	2.5	3	4	5	6	8										
t (Min)	1.04	1.3	1.56	2.08	2.6	3.12	4.16										
Length/dim	M3	M4	M5	M6	M8	M10	M12										
35	■◆	■◆	■◆	■◆	■◆	■◆	■◆										
40	■◆	■◆	■◆	■◆	■◆	■◆	■◆										
45	■◆	■◆	■◆	■◆	■◆	■◆	■◆										
50	■◆	■◆	■◆	■◆	■◆	■◆	■◆										
55		■◆	■◆	■◆	■◆	■◆	■◆										
60		■◆	■◆	■◆	■◆	■◆	■◆										
65			■◆	■◆	■◆	■◆	■◆										
70			■◆	■◆	■◆	■◆	■◆										
75			■◆	■◆	■◆	■◆	■◆										
80			■◆	■◆	■◆	■◆	■◆										
90				■◆	■◆	■◆	■◆										
100				■◆	■◆	■◆	■◆										
110				■◆	■◆	■◆	■◆										
120				■◆	■◆	■◆	■◆										

[CLICK HERE TO RETURN TO THE CONTENTS PAGE](#)

+ 37 064 411 786

Inquiry@invayear.com

www.invayear.com

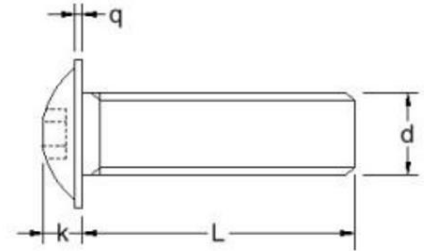
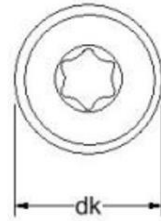
FLANGED TX BUTTONS ISO 7380-2

 Material grades: **A2**

dk (Max)	6.9	9.4	11.8	13.6	17.8	21.9	26										
k	1.65	2.2	2.75	3.3	4.4	5.5	6.6										
Pitch	0.5	0.7	0.8	1.0	1.25	1.5	1.75										
q	0.7	0.8	1.0	1.2	1.5	2.0	2.4										
Length/dim	M3	M4	M5	M6	M8	M10	M12										
3	■																
4	■	■															
5	■	■	■														
6	■	■	■	■													
8	■	■	■	■	■												
10	■	■	■	■	■												
12	■	■	■	■	■	■											
14	■	■	■	■	■	■	■										
16	■	■	■	■	■	■	■	■									
18	■	■	■	■	■	■	■	■	■								
20	■	■	■	■	■	■	■	■	■								
22	■	■	■	■	■	■	■	■	■								
25	■	■	■	■	■	■	■	■	■								
30	■	■	■	■	■	■	■	■	■								
35	■	■	■	■	■	■	■	■	■								
40	■	■	■	■	■	■	■	■	■								

CLICK HERE TO RETURN TO THE CONTENTS PAGE



+ 37 064 411 786



Inquiry@invayear.com



www.invayear.com

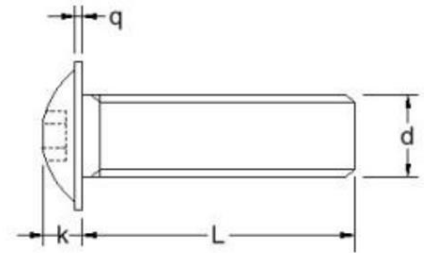
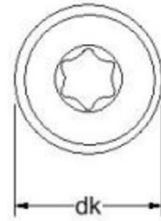

Material grades: A2: ■

dk (Max)	6.9	9.4	11.8	13.6	17.8	21.9	26											
k	1.65	2.2	2.75	3.3	4.4	5.5	6.6											
Pitch	0.5	0.7	0.8	1.0	1.25	1.5	1.75											
q	0.7	0.8	1.0	1.2	1.5	2.0	2.4											
Length/dim	M3	M4	M5	M6	M8	M10	M12											
45	■	■	■	■	■	■	■											
50	■	■	■	■	■	■	■											
55		■	■	■	■	■	■											
60		■	■	■	■	■	■											
65			■	■	■	■	■											
70			■	■	■	■	■											
75			■	■	■	■	■											
80			■	■	■	■	■											
90				■	■	■	■											
100				■	■	■	■											
110				■	■	■	■											
120				■	■	■	■											

[CLICK HERE TO RETURN TO THE CONTENTS PAGE](#)



+ 37 064 411 786



Inquiry@invayear.com

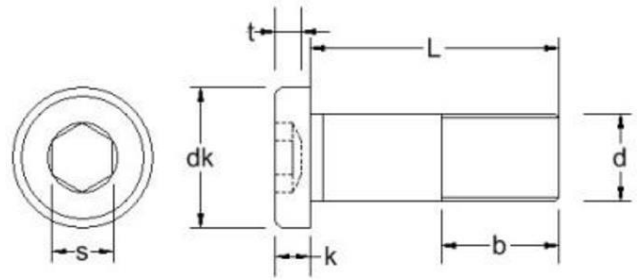

www.invayear.com

LOW HEAD SOCKET CAP SCREWS DIN 7984

Material grades: A2: ■ A4: ◆

b (Max)	12	14	16	18	22	26	30	38	46	54									
dk (Max)	5.5	7.0	8.5	10	13	16	18	24	30	36									
k (Max)	2	2.8	3.5	4	5	6	7	9	11	13									
Pitch	0.5	0.7	0.8	1.0	1.25	1.5	1.75	2.0	2.5	3.0									
s	2	2.5	3	4	5	7	8	12	14	17									
t	1.5	2.3	2.7	3.0	3.8	4.5	5.0	5.5	7.5	8.0									
Length/dim	M3	M4	M5	M6	M8	M10	M12	M16	M20	M24									
3	■ ◆																		
4	■ ◆	■ ◆																	
5	■ ◆	■ ◆	◆																
6	■ ◆	■ ◆	■ ◆	■ ◆															
8	■ ◆	■ ◆	■ ◆	■ ◆	■ ◆														
10	■ ◆	■ ◆	■ ◆	■ ◆	■ ◆	■ ◆													
12	■ ◆	■ ◆	■ ◆	■ ◆	■ ◆	■ ◆	■ ◆												
14	■ ◆	■ ◆	■ ◆	■ ◆	■ ◆	■ ◆	■ ◆												
16	■ ◆	■ ◆	■ ◆	■ ◆	■ ◆	■ ◆	■ ◆	■ ◆											
18	■ ◆	■ ◆	■ ◆	■ ◆	■ ◆	■ ◆	■ ◆	■ ◆											
20	■ ◆	■ ◆	■ ◆	■ ◆	■ ◆	■ ◆	■ ◆	■ ◆	■ ◆										
22	■ ◆	■ ◆	■ ◆	■ ◆	■ ◆	■ ◆	■ ◆	■ ◆											
25	■ ◆	■ ◆	■ ◆	■ ◆	■ ◆	■ ◆	■ ◆	■ ◆	■ ◆										
30	■ ◆	■ ◆	■ ◆	■ ◆	■ ◆	■ ◆	■ ◆	■ ◆	■ ◆	■ ◆									

CLICK HERE TO RETURN TO THE CONTENTS PAGE



+ 37 064 411 786



Inquiry@invayear.com



www.invayear.com

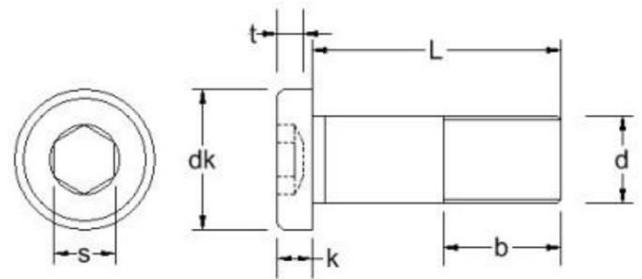

Material grades: A2: ■ A4: ◆

	M3	M4	M5	M6	M8	M10	M12	M16	M20	M24						
b (Max)	12	14	16	18	22	26	30	38	46	54						
dk (Max)	5.5	7.0	8.5	10	13	16	18	24	30	36						
k (Max)	2	2.8	3.5	4	5	6	7	9	11	13						
Pitch	0.5	0.7	0.8	1.0	1.25	1.5	1.75	2.0	2.5	3.0						
s	2	2.5	3	4	5	7	8	12	14	17						
t	1.5	2.3	2.7	3.0	3.8	4.5	5.0	5.5	7.5	8.0						
Length/dim	M3	M4	M5	M6	M8	M10	M12	M16	M20	M24						
35	■◆	■◆	■◆	■◆	■◆	■◆	■◆	■◆	■◆							
40	■◆	■◆	■◆	■◆	■◆	■◆	■◆	■◆	■◆	■◆						
45	■◆	■◆	■◆	■◆	■◆	■◆	■◆	■◆	■◆	■◆						
50	■◆	■◆	■◆	■◆	■◆	■◆	■◆	■◆	■◆	■◆						
55		■◆	■◆	■◆	■◆	■◆	■◆	■◆	■◆	■◆						
60		■◆	■◆	■◆	■◆	■◆	■◆	■◆	■◆	■◆						
65			■◆	■◆	■◆	■◆	■◆	■◆	■◆	■◆						
70			■◆	■◆	■◆	■◆	■◆	■◆	■◆	■◆						
75			■◆	■◆	■◆	■◆	■◆	■◆	■◆	■◆						
80			■◆	■◆	■◆	■◆	■◆	■◆	■◆	■◆						
90				■◆	■◆	■◆	■◆	■◆	■◆	■◆						
100				■◆	■◆	■◆	■◆	■◆	■◆	■◆						
110					■◆	■◆	■◆	■◆	■◆	■◆						
120				■◆	■◆	■◆	■◆	■◆	■◆	■◆						
130								■◆	■◆	■◆						
140								■◆	■◆	■◆						
150								■◆	■◆	■◆						

CLICK HERE TO RETURN TO THE CONTENTS PAGE



+ 37 064 411 786



Inquiry@invayear.com

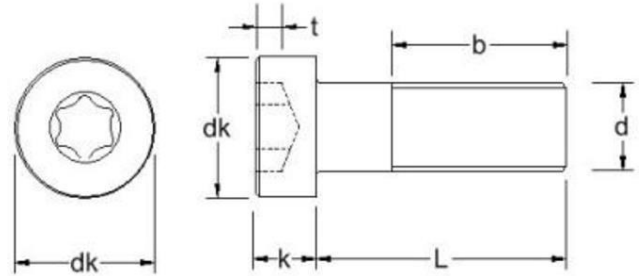

www.invayear.com

TX LOW HEAD CAP SCREWS ISO 14580

 Material grades: **A2:** ■

b (Max) = L	25	25	25	38	38	38	38											
dk (Max)	3.8	4.5	5.5	7.0	8.5	10	13											
k (Max)	1.55	1.85	2.4	3.1	3.65	4.4	5.8											
Pitch	0.4	0.45	0.5	0.7	0.8	1.0	1.25											
t (Max)	0.84	0.91	1.27	1.66	1.91	2.29	3.05											
Length/dim	M2	M2.5	M3	M4	M5	M6	M8											
3	■	■																
4	■	■	■															
5	■	■	■															
6	■	■	■	■														
8	■	■	■	■	■	■												
10	■	■	■	■	■	■	■											
12	■	■	■	■	■	■	■	■										
16	■	■	■	■	■	■	■	■										
20	■	■	■	■	■	■	■	■										
25			■	■	■	■	■	■										
30			■	■	■	■	■	■										
35			■	■	■	■	■	■										
40			■	■	■	■	■	■										
45			■	■	■	■	■	■										
50			■	■	■	■	■	■										
55					■	■	■	■										
60					■	■	■	■										
65						■	■	■										
70						■	■	■										
75							■	■										
80							■	■										

[CLICK HERE TO RETURN TO THE CONTENTS PAGE](#)



+ 37 064 411 786



Inquiry@invayear.com



www.invayear.com

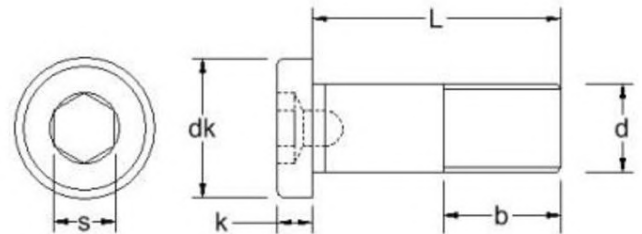

Material grades: A2: ■ A4: ◆

b (Max)	12	14	16	18	22	26	30	38	46	54							
dk (Max)	5.5	7.0	8.5	10	13	16	18	24	30	36							
k (Max)	2	2.8	3.5	4	5	6.5	7.5	10	12	14							
Pitch	0.5	0.6	0.8	1.0	1.25	1.5	1.75	2	2.5	3							
s	2	3	4	5	6	8	10	14	17	19							
Length/dim	M3	M4	M5	M6	M8	M10	M12	M16	M20	M24							
4	■◆																
5	■◆	■◆															
6	■◆	■◆	■◆														
8	■◆	■◆	■◆	■◆													
10	■◆	■◆	■◆	■◆	■◆												
12	■◆	■◆	■◆	■◆	■◆	■◆											
14	■◆	■◆	■◆	■◆	■◆	■◆	■◆										
16	■◆	■◆	■◆	■◆	■◆	■◆	■◆	■◆									
18	■◆	■◆	■◆	■◆	■◆	■◆	■◆	■◆									
20	■◆	■◆	■◆	■◆	■◆	■◆	■◆	■◆	■◆								
22	■◆	■◆	■◆	■◆	■◆	■◆	■◆	■◆									
25	■◆	■◆	■◆	■◆	■◆	■◆	■◆	■◆	■◆								
30	■◆	■◆	■◆	■◆	■◆	■◆	■◆	■◆	■◆	■◆							
35	■◆	■◆	■◆	■◆	■◆	■◆	■◆	■◆	■◆	■◆	■◆						
40	■◆	■◆	■◆	■◆	■◆	■◆	■◆	■◆	■◆	■◆	■◆						

CLICK HERE TO RETURN TO THE CONTENTS PAGE



+ 37 064 411 786



Inquiry@invayear.com

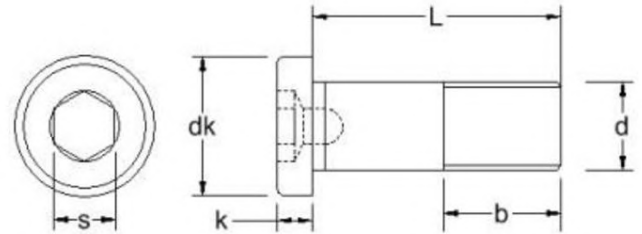

www.invayear.com

LOW HEAD SOCKET CAP SCREWS DIN 6912

Material grades: A2: ■ A4: ◆

b (Max)	12	14	16	18	22	26	30	38	46	54								
dk (Max)	5.5	7.0	8.5	10	13	16	18	24	30	36								
k (Max)	2	2.8	3.5	4	5	6.5	7.5	10	12	14								
Pitch	0.5	0.6	0.8	1.0	1.25	1.5	1.75	2	2.5	3								
s	2	3	4	5	6	8	10	14	17	19								
Length/dim	M3	M4	M5	M6	M8	M10	M12	M16	M20	M24								
45	■◆	■◆	■◆	■◆	■◆	■◆	■◆	■◆	■◆	■◆								
50	■◆	■◆	■◆	■◆	■◆	■◆	■◆	■◆	■◆	■◆								
55		■◆	■◆	■◆	■◆	■◆	■◆	■◆	■◆	■◆								
60		■◆		■◆	■◆	■◆	■◆	■◆	■◆	■◆								
65			■◆	■◆	■◆	■◆	■◆	■◆	■◆	■◆								
70			■	■◆	■◆	■◆	■◆	■◆	■◆	■◆								
75			■◆	■◆	■	■◆	■◆	■◆	■◆	■◆								
80			■◆	■◆	■◆	■◆	■◆	■◆	■◆	■◆								
90				■◆	■◆	■◆	■◆	■◆	■◆	■◆								
100				■	■◆	■◆	■◆	■◆	■◆	■◆								
110					■◆	■◆	■◆	■◆	■◆	■◆								
120				■	■◆	■◆	■◆	■◆	■◆	■◆								
130								■◆	■◆	■◆								
140								■◆	■◆	■◆								
150								■◆	■◆	■◆								

[CLICK HERE TO RETURN TO THE CONTENTS PAGE](#)



+ 37 064 411 786



Inquiry@invayear.com



www.invayear.com

SOCKET COUNTERSUNK SCREWS DIN 7991

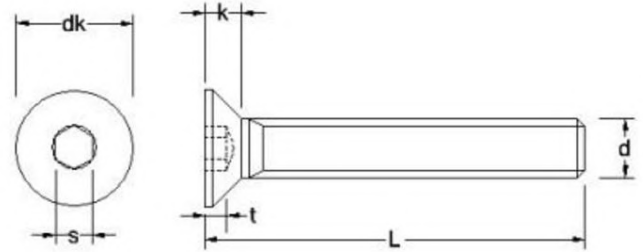

Material grades: A2: ■ A4: ◆

dk (Max)	4	5	6	6.5	8	10	12	16	20	24	30	36	39				
k (Max)	1.24	1.55	1.7	2.1	2.3	2.8	3.3	4.4	5.5	6.5	7.5	8.5	*				
Pitch	0.4	0.45	0.5	0.6	0.7	0.8	1.0	1.25	1.5	1.75	2.0	2.5	3.0				
s	1.27	1.50	2	2	2.5	3	4	5	6	8	10	12	14				
t (Max)	0.65	0.80	1.2	1.3	1.8	2.3	2.5	3.5	4.4	4.6							
Length/dim	M2	M2.5	M3	M3.5	M4	M5	M6	M8	M10	M12	M16	M20	M24				
3	■◆																
4	■◆	■◆	■◆														
5	■◆	■◆	■◆	■◆	■◆												
6	■◆	■◆	■◆	■◆	■◆	■◆											
8	■◆	■◆	■◆	■◆	■◆	■◆	■◆										
10	■◆	■◆	■◆	■◆	■◆	■◆	■◆	■◆									
12	■◆	■◆	■◆	■◆	■◆	■◆	■◆	■◆	■◆								
14			■◆		■◆	■◆		■◆	■◆								
16	■◆	■◆	■◆	■◆	■◆	■◆	■◆	■◆	■◆	■◆	■◆						
18			■◆		■◆	■◆	■◆	■◆	■◆	■◆	■◆						
20	■◆	■◆	■◆	■◆	■◆	■◆	■◆	■◆	■◆	■◆	■◆	■◆					
22			■◆		■◆	■◆	■◆	■◆	■◆	■◆	■◆						
25			■◆	■◆	■◆	■◆	■◆	■◆	■◆	■◆	■◆	■◆					
30			■◆	■◆	■◆	■◆	■◆	■◆	■◆	■◆	■◆	■◆	■◆				
35			■◆		■◆	■◆	■◆	■◆	■◆	■◆	■◆	■◆	■◆				
40			■◆		■◆	■◆	■◆	■◆	■◆	■◆	■◆	■◆	■◆	■◆			
45			■◆		■◆	■◆	■◆	■◆	■◆	■◆	■◆	■◆	■◆	■◆			
50			■◆		■◆	■◆	■◆	■◆	■◆	■◆	■◆	■◆	■◆	■◆			

[CLICK HERE TO RETURN TO THE CONTENTS PAGE](#)



+ 37 064 411 786



Inquiry@invayear.com



www.invayear.com

SOCKET COUNTERSUNK SCREWS DIN 7991

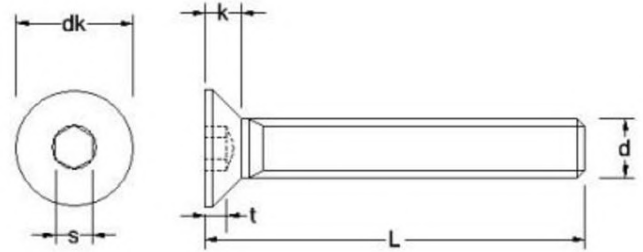

Material grades: A2: ■ A4: ◆

dk (Max)	4	5	6	6.5	8	10	12	16	20	24	30	36	39				
k (Max)	1.24	1.55	1.7	2.1	2.3	2.8	3.3	4.4	5.5	6.5	7.5	8.5	*				
Pitch	0.4	0.45	0.5	0.6	0.7	0.8	1.0	1.25	1.5	1.75	2.0	2.5	3.0				
s	1.27	1.50	2	2	2.5	3	4	5	6	8	10	12	14				
t (Max)	0.65	0.80	1.2	1.3	1.8	2.3	2.5	3.5	4.4	4.6							
Length/dim	M2	M2.5	M3	M3.5	M4	M5	M6	M8	M10	M12	M16	M20	M24				
55						■ ◆	■ ◆	■ ◆	■ ◆	■ ◆	■ ◆	■ ◆	■ ◆				
60					■ ◆	■ ◆	■ ◆	■ ◆	■ ◆	■ ◆	■ ◆	■ ◆	■ ◆				
65					■ ◆	■ ◆	■ ◆	■ ◆	■ ◆	■ ◆	■ ◆	■ ◆	■ ◆				
70					■ ◆	■ ◆	■ ◆	■ ◆	■ ◆	■ ◆	■ ◆	■ ◆	■ ◆				
75						■ ◆	■ ◆	■ ◆	■ ◆	■ ◆	■ ◆	■ ◆	■ ◆				
80						■ ◆	■ ◆	■ ◆	■ ◆	■ ◆	■ ◆	■ ◆	■ ◆				
85									■ ◆	■							
90						■ ◆	■ ◆	■ ◆	■ ◆	■ ◆	■ ◆	■ ◆	■ ◆				
100						■ ◆	■ ◆	■ ◆	■ ◆	■ ◆	■ ◆	■ ◆	■ ◆				
110							■ ◆	■ ◆	■ ◆	■ ◆	■ ◆	■ ◆	■ ◆				
120							■ ◆	■ ◆	■ ◆	■ ◆	■ ◆	■ ◆	■ ◆				
130							■ ◆	■ ◆	■ ◆	■ ◆	■ ◆	■ ◆	■ ◆				
140							■ ◆	■ ◆	■ ◆	■ ◆	■ ◆	■ ◆	■ ◆				
150							■ ◆	■ ◆	■ ◆	■ ◆	■ ◆	■ ◆	■ ◆				
160								■ ◆	■ ◆	■ ◆	■ ◆	■ ◆	■ ◆				
170								■ ◆	■ ◆	■ ◆	■ ◆	■ ◆	■ ◆				
180								■ ◆	■ ◆	■ ◆	■ ◆	■ ◆	■ ◆				
190								■ ◆	■ ◆	■ ◆	■ ◆	■ ◆	■ ◆				
200								■ ◆	■ ◆	■ ◆	■ ◆	■ ◆	■ ◆				

CLICK HERE TO RETURN TO THE CONTENTS PAGE



+ 37 064 411 786



Inquiry@invayear.com

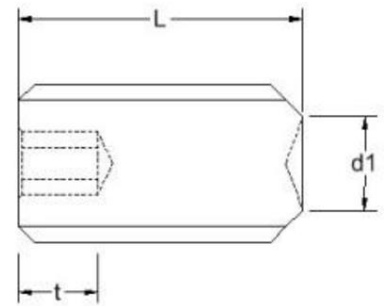

www.invayear.com

SOCKET SET SCREWS CUP POINT DIN 916

Material grades: A2: ■ A4: ◆

dI (Max)	0.8	1	1.2	1.4	1.4	2	2.5	3	5	6	8	10	14				
Pitch	0.35	0.4	0.45	0.5	0.6	0.7	0.8	1.0	1.25	1.5	1.75	2.0	2.5				
s	0.7	0.9	1.3	1.5	1.5	2	2.5	3	4	5	6	8	10				
t (Min)	0.7	0.8	1.2	1.2	1.2	1.5	2	2	3	4	4.8	6.4	8				
Length/dim	M1.6	M2	M2.5	M3	M3.5	M4	M5	M6	M8	M10	M12	M16	M20				
2	■	■◆															
2.5	■	■	■														
3	■	■◆	■◆	■◆	■◆												
4	■	■◆	■◆	■◆	■◆	■◆	■	■									
5	■	■◆	■◆	■◆	■◆	■◆	■◆	■◆									
6	■	■◆	■◆	■◆	■◆	■◆	■◆	■◆	■								
7								■									
8	■	■◆	■◆	■◆	■◆	■◆	■◆	■◆	■◆	■							
10	■	■◆	■◆	■◆	■◆	■◆	■◆	■◆	■◆	■◆	■						
12	■	■◆	■◆	■◆	■◆	■◆	■◆	■◆	■◆	■◆	■◆						
14				■		■	◆	■◆	■◆								
16		■◆	■	■◆		■◆	■◆	■◆	■◆	■◆	■◆	■◆	■◆				
18							■		■								
20				■◆		■◆	■◆	■◆	■◆	■◆	■◆	■◆	■◆	■◆			
25				■◆		◆	■◆	■◆	■◆	■◆	■◆	■◆	■◆	■◆			
28							■										

CLICK HERE TO RETURN TO THE CONTENTS PAGE



+ 37 064 411 786



Inquiry@invayear.com

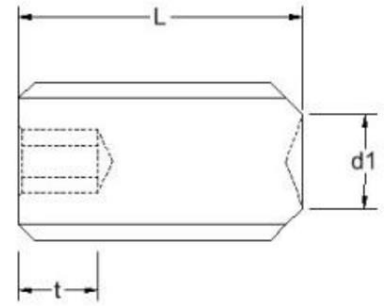
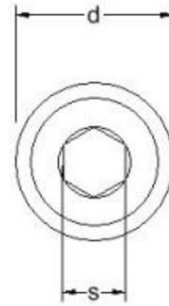

www.invayear.com

SOCKET SET SCREWS CUP POINT DIN 916

Material grades: A2: ■ A4: ◆

dI (Max)	0.8	1	1.2	1.4	1.4	2	2.5	3	5	6	8	10	14				
Pitch	0.35	0.4	0.45	0.5	0.6	0.7	0.8	1.0	1.25	1.5	1.75	2.0	2.5				
s	0.7	0.9	1.3	1.5	1.5	2	2.5	3	4	5	6	8	10				
t (Min)	0.7	0.8	1.2	1.2	1.2	1.5	2	2	3	4	4.8	6.4	8				
Length/dim	M1.6	M2	M2.5	M3	M3.5	M4	M5	M6	M8	M10	M12	M16	M20				
30				■ ◆		■ ◆	■ ◆	■ ◆	■ ◆	■ ◆	■ ◆	■ ◆	■ ◆				
35						■ ◆	■ ◆	■ ◆	■ ◆	■ ◆	■ ◆	■ ◆	■ ◆				
40						■ ◆	■ ◆	■ ◆	■ ◆	■ ◆	■ ◆	■ ◆	■ ◆				
45								■ ◆	■ ◆	■ ◆	■ ◆	■ ◆	■ ◆				
50						■ ◆	■ ◆	■ ◆	■ ◆	■ ◆	■ ◆	■ ◆	■ ◆				
55								■ ◆		■ ◆	■ ◆	■ ◆	■ ◆				
60							■ ◆	■ ◆	■ ◆	■ ◆	■ ◆	■ ◆	■ ◆				
65									■ ◆	■ ◆	■ ◆	■ ◆	■ ◆				
70									■ ◆	■ ◆	■ ◆	■ ◆	■ ◆				
80											■ ◆	■ ◆	■ ◆				
90												■ ◆	■ ◆				
100												■ ◆	■ ◆				

CLICK HERE TO RETURN TO THE CONTENTS PAGE



+ 37 064 411 786



Inquiry@invayear.com

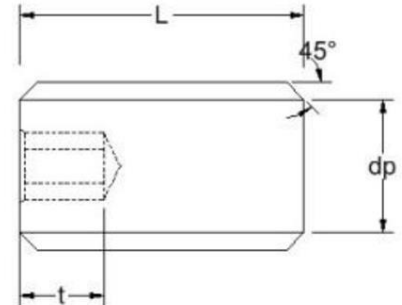

www.invayear.com

SOCKET SET SCREWS FLAT POINT DIN 913

Material grades: A2: ■ A4: ◆

dp (Max)	0.8	1	1.5	2	2.5	3.5	4	5.5	7	8.5	12	15						
Pitch	0.35	0.4	0.45	0.5	0.7	0.8	1.0	1.25	1.5	1.75	2.0	2.5						
s	0.7	0.9	1.3	1.5	2	2.5	3	4	5	6	8	10						
t (Min)	0.7	0.8	1.2	1.2	1.5	2	2	3	4	4.8	6.4	8						
Length/dim	M1.6	M2	M2.5	M3	M4	M5	M6	M8	M10	M12	M16	M20						
2	■	◆																
2.5	■	■	■															
3	■	◆	◆	◆	◆													
4	■	◆	◆	◆	◆	◆	■											
5	■	◆	◆	◆	◆	◆	◆											
6	■	◆	◆	◆	◆	◆	◆	◆	◆									
8	■	◆	◆	◆	◆	◆	◆	◆	◆	◆								
10	■	◆	◆	◆	◆	◆	◆	◆	◆	◆								
12		◆	◆	◆	◆	◆	◆	◆	◆	◆	◆							
14		◆	■	■	■	◆	◆	◆	◆	◆	◆							
16		◆	◆	◆	◆	◆	◆	◆	◆	◆	◆	◆						
18							◆		◆									
20				◆	◆	◆	◆	◆	◆	◆	◆	◆	■					
25				◆	◆	◆	◆	◆	◆	◆	◆	◆	■					
30				◆	◆	◆	◆	◆	◆	◆	◆	◆	◆	◆				
35					◆	◆	◆	◆	◆	◆	◆	◆	◆	◆				

CLICK HERE TO RETURN TO THE CONTENTS PAGE



+ 37 064 411 786



Inquiry@invayear.com

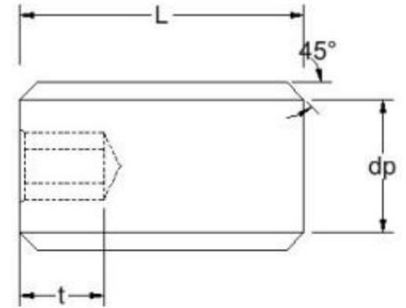

www.invayear.com

SOCKET SET SCREWS FLAT POINT DIN 913

Material grades: A2: ■ A4: ◆

dp (Max)	0.8	1	1.5	2	2.5	3.5	4	5.5	7	8.5	12	15						
Pitch	0.35	0.4	0.45	0.5	0.7	0.8	1.0	1.25	1.5	1.75	2.0	2.5						
s	0.7	0.9	1.3	1.5	2	2.5	3	4	5	6	8	10						
t (Min)	0.7	0.8	1.2	1.2	1.5	2	2	3	4	4.8	6.4	8						
Length/dim	M1.6	M2	M2.5	M3	M4	M5	M6	M8	M10	M12	M16	M20						
40					■◆	■◆	■◆	■◆	■◆	■◆	■◆	■◆						
45						■	■◆	■◆	■◆	■◆	■◆	■◆						
50						■	■◆	■◆	■◆	■◆	■◆	■◆						
55							■◆	■◆	■◆	■◆	■◆							
60						■	■◆	■◆	■◆	■◆	■◆	■◆						
70							■◆	■	■◆	■◆	■◆	■◆						
80								■	■◆	■◆	■◆	■◆						
90								■	■◆	■◆	■◆	■◆						
100								■	■◆	■◆	■◆	■◆						
110								■	■									
120								■	■									
130									■									
140									■									
150									■									
160									■									
170									■									
180									■									
190									■									

[CLICK HERE TO RETURN TO THE CONTENTS PAGE](#)



+ 37 064 411 786



Inquiry@invayear.com



www.invayear.com

SOCKET SET SCREWS CONE POINT DIN 914

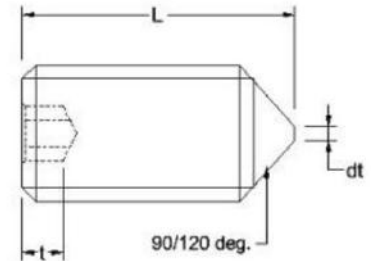
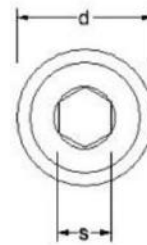

Material grades: A2: ■ A4: ◆

dt (Max)	*	*	*	*	*	*	1.5	2	2.5	3	4	5				
Pitch	0.35	0.4	0.45	0.5	0.7	0.8	1.0	1.25	1.5	1.75	2.0	2.5				
s	0.7	0.9	1.3	1.5	2	2.5	3	4	5	6	8	10				
τ (Min)	0.7	0.8	1.2	1.2	1.5	2	2	3	4	4.8	6.4	8				
Length/dim	M1.6	M2	M2.5	M3	M4	M5	M6	M8	M10	M12	M16	M20				
2	■	◆														
2.5	■		■													
3	■	◆	◆	◆	■											
4	■	◆	◆	◆	◆	■										
5	■	◆	◆	◆	◆	◆	■									
6		◆	◆	◆	◆	◆	◆	■								
8		◆	◆	◆	◆	◆	◆	◆	■							
10		◆	◆	◆	◆	◆	◆	◆	◆	◆						
12		◆	◆	◆	◆	◆	◆	◆	◆	◆	◆					
14		◆	◆	◆	◆	◆	■	◆	◆	◆						
16		◆	◆	◆	◆	◆	◆	◆	◆	◆	◆					
18						■	■	◆								
20				◆	◆	◆	◆	◆	◆	◆	◆	◆				
22							■									
25				◆	◆	◆	◆	◆	◆	◆	◆	◆	◆			
30				◆	◆	◆	◆	◆	◆	◆	◆	◆	◆	◆		
35					◆	◆	◆	◆	◆	◆	◆	◆	◆	◆		
40					◆	◆	◆	◆	◆	◆	◆	◆	◆	◆		
45						◆	◆	◆	◆	◆	◆	◆	◆	◆		
50						◆	◆	◆	◆	◆	◆	◆	◆	◆		
55							◆	◆	◆	◆	◆	◆	◆	■		
60							◆	◆	◆	◆	◆	◆	◆	◆		
70									◆	◆	◆	◆	◆	◆		
80										◆	◆	◆	◆	◆		
90											◆	◆	◆	◆		
100												◆	◆	◆		

CLICK HERE TO RETURN TO THE CONTENTS PAGE



+ 37 064 411 786



Inquiry@invayear.com

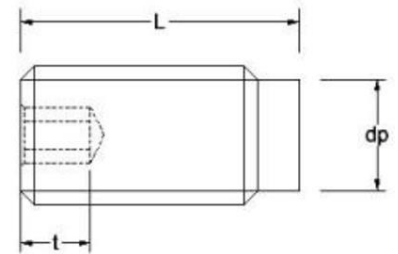
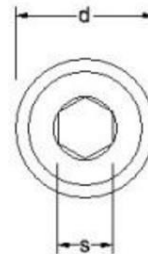

www.invayear.com

SOCKET SET SCREWS DOG POINT DIN 915

Material grades: A2: ■ A4: ◆

dp (Max)	1	1.5	2	2.5	3.5	4	5.5	7	8.5	12	15						
Pitch	0.4	0.45	0.5	0.7	0.8	1.0	1.25	1.5	1.75	2.0	2.5						
s	0.9	1.3	1.5	2	2.5	3	4	5	6	8	10						
t (Min)	0.8	1.2	1.2	1.5	2	2	3	4	4.8	6.4	8						
Length/dim	M2	M2.5	M3	M4	M5	M6	M8	M10	M12	M16	M20						
3	■◆	■◆	■◆														
4	■◆	■◆	■◆	■◆													
5	■◆	■◆	■◆	■◆	■◆												
6	■◆	■◆	■◆	■◆	■◆	■◆											
8	■◆	■◆	■◆	■◆	■◆	■◆	■◆										
10	■◆	■◆	■◆	■◆	■◆	■◆	■◆	■◆									
12	■◆	■◆	■◆	■◆	■◆	■◆	■◆	■◆	■◆								
14	■◆	■◆	■◆		■◆	■◆	■◆	■◆	■◆								
16	■◆	■◆	■◆	■◆	■◆	■◆	■◆	■◆	■◆	■◆							
18					■		■										
20	■		■◆	■◆	■◆	■◆	■◆	■◆	■◆	■◆	■◆						
25			■◆	■◆	■◆	■◆	■◆	■◆	■◆	■◆	■◆						
30			■◆	■◆	■◆	■◆	■◆	■◆	■◆	■◆	■◆						
35					■◆	■◆	■◆	■◆	■◆	■◆	■◆						
40					■◆	■◆	■◆	■◆	■◆	■◆	■◆						
45							■◆	■◆	■◆	■◆	■◆						
50							■◆	■◆	■◆	■◆	■◆						
55								■◆	■◆	■◆	■◆						
60							■◆	■◆	■◆	■◆	■◆	■◆					
65											■◆	■◆					
70									■◆	■◆	■◆	■◆					
80											■◆	■◆					
90												■					

CLICK HERE TO RETURN TO THE CONTENTS PAGE



+ 37 064 411 786



Inquiry@invayear.com



www.invayear.com

SOCKET CAP SCREWS ANSI B18.3

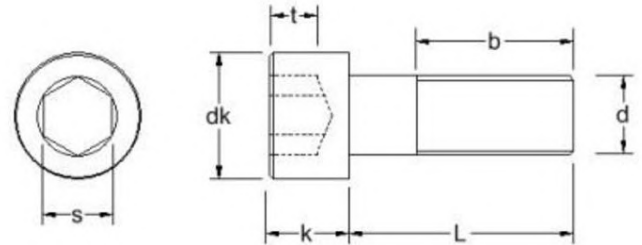

Material grades: A2: ■ A4: ◆

b	0.50	0.99	0.62	0.99	0.62	0.99	0.62	0.99	0.62	0.99	0.62	0.99	0.75	0.99	0.75	0.99	0.75	1.00	0.75	1.05	0.75	1.05	0.88	1.19	0.88	1.19	0.88	1.27	0.88	1.27	0.88	1.27					
dk (Max)	0.096	0.118	0.118	0.140	0.140	0.161	0.161	0.183	0.183	0.205	0.226	0.226	0.270	0.270	0.312	0.312	0.343																				
k (Max)	0.060	0.073	0.073	0.086	0.086	0.099	0.099	0.112	0.112	0.125	0.138	0.138	0.164	0.164	0.190	0.190	0.216																				
s	0.050	1/16	1/16	5/64	5/64	5/64	5/64	3/32	3/32	3/32	7/64	7/64	9/64	9/64	5/32	5/32	5/32																				
τ (Min)	0.025	0.031	0.031	0.038	0.038	0.044	0.044	0.051	0.051	0.057	0.064	0.064	0.077	0.077	0.090	0.090	0.090																				
Length/dim	0-80	1-64	1-72	2-56	2-64	3-48	3-56	4-40	4-48	5-40	6-32	6-40	8-32	8-36	10-24	10-32	12-24																				
3/32	■																																				
1/8	■	■	■	■	■			■				■	■	■																							
5/32	■	■	■	■	■																																
3/16	■	■	■	■	■	■		◆	■			■	■	■	■	■	■																				
7/32	■	■	■																																		
1/4	■	■	■	◆	■	■	■	◆	■	■	■	◆	■	◆	■	◆	■	◆	■	◆	■	◆	■	◆	■	◆	■	◆	■	◆	■	◆	■	◆	■	◆	
5/16	■	■	■	◆	■	■	■	◆	■	■	■	◆	■	◆	■	◆	■	◆	■	◆	■	◆	■	◆	■	◆	■	◆	■	◆	■	◆	■	◆	■	◆	
3/8	■	■	■	◆	■	■	■	◆	■	■	■	◆	■	◆	■	◆	■	◆	■	◆	■	◆	■	◆	■	◆	■	◆	■	◆	■	◆	■	◆	■	◆	
7/16	■	■	■	◆	■	■	■	◆	■	■	■	◆	■	◆	■	◆	■	◆	■	◆	■	◆	■	◆	■	◆	■	◆	■	◆	■	◆	■	◆	■	◆	
1/2	■	■	■	◆	■	■	■	◆	■	■	■	◆	■	◆	■	◆	■	◆	■	◆	■	◆	■	◆	■	◆	■	◆	■	◆	■	◆	■	◆	■	◆	
9/16	■	■	■	■	■	■	■	◆	■	■	■	◆	■	◆	■	◆	■	◆	■	◆	■	◆	■	◆	■	◆	■	◆	■	◆	■	◆	■	◆	■	◆	
5/8	■	■	■	■	■	■	■	◆	■	■	■	◆	■	◆	■	◆	■	◆	■	◆	■	◆	■	◆	■	◆	■	◆	■	◆	■	◆	■	◆	■	◆	
3/4	■		■	■	■	■	■	◆	■	■	■	◆	■	◆	■	◆	■	◆	■	◆	■	◆	■	◆	■	◆	■	◆	■	◆	■	◆	■	◆	■	◆	
7/8				■		■	■	◆	■			■	◆	■	◆	■	◆	■	◆	■	◆	■	◆	■	◆	■	◆	■	◆	■	◆	■	◆	■	◆	■	◆
1	■			■		■	■	◆	■	■	■	◆	■	◆	■	◆	■	◆	■	◆	■	◆	■	◆	■	◆	■	◆	■	◆	■	◆	■	◆	■	◆	

CLICK HERE TO RETURN TO THE CONTENTS PAGE



+ 37 064 411 786



Inquiry@invayear.com

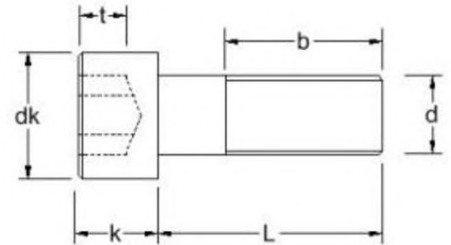

www.invayear.com

SOCKET CAP SCREWS ANSI B18.3

Material grades: A2: ■ A4: ◆

b	1.00 - 1.50	1.00 - 1.50	1.12 - 1.71	1.12 - 1.71	1.25 - 1.94	1.25 - 1.94	1.38 - 2.17	1.38 - 2.17	1.50 - 2.38	1.50 - 2.38	1.75 - 2.82	1.75 - 2.82	2.00 - 3.25	2.00 - 3.25	2.25 - 3.69	2.25 - 3.69	2.50 - 4.12
dk (Max)	0.375	0.375	0.469	0.469	0.562	0.562	0.656	0.656	0.750	0.750	0.938	0.938	1.125	1.125	1.312	1.312	1.500
k (Max)	0.250	0.250	0.312	0.312	0.375	0.375	0.438	0.438	0.500	0.500	0.625	0.625	0.750	0.750	0.875	0.875	1.000
s	3/16	3/16	1/4	1/4	5/16	5/16	3/8	3/8	3/8	3/8	1/2	1/2	5/8	5/8	3/4	3/4	3/4
t (Min)	0.120	0.120	0.151	0.151	0.182	0.182	0.213	0.213	0.245	0.245	0.307	0.307	0.370	0.370	0.432	0.432	0.495
Length/dim	1/4-20	1/4-28	5/16-18	5/16-24	3/8-16	3/8-24	7/16-14	7/16-20	1/2-13	1/2-20	5/8-11	5/8-18	3/4-10	3/4-16	7/8-9	7/8-14	1-8
3/32																	
1/8																	
5/32																	
3/16																	
7/32																	
1/4	■	■	■	■													
5/16	■	■															
3/8	■◆	■	■	■	■												
7/16	■◆																
1/2	■◆	■◆	■◆	■◆	■◆	■	■		■								
9/16	■◆																
5/8	■◆	■◆	■◆	■◆	■◆	■			■								
3/4	■◆	■◆	■◆	■◆	■◆	■◆	■		■◆	■							
7/8	■◆	■◆	■◆	■◆	■◆	■◆	■	■	■◆								
1	■◆	■◆	■◆	■◆	■◆	■◆	■	■	■◆	■	■◆	■	■				

CLICK HERE TO RETURN TO THE CONTENTS PAGE



+ 37 064 411 786



Inquiry@invayear.com



www.invayear.com

SOCKET CAP SCREWS ANSI B18.3

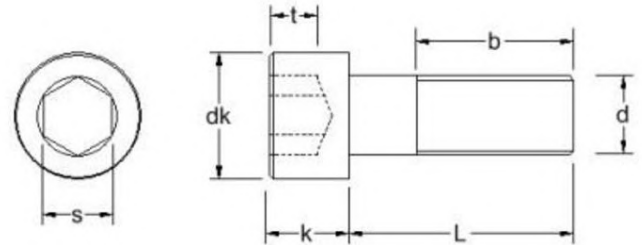

Material grades: A2: ■ A4: ◆

b	0.50 - 0.99	0.62 - 0.99	0.62 - 0.99	0.62 - 0.99	0.62 - 0.99	0.62 - 0.99	0.62 - 0.99	0.75 - 0.99	0.75 - 0.99	0.75 - 1.00	0.75 - 1.05	0.75 - 1.05	0.88 - 1.19	0.88 - 1.19	0.88 - 1.27	0.88 - 1.27	0.88 - 1.27
dk (Max)	0.096	0.118	0.118	0.140	0.140	0.161	0.161	0.183	0.183	0.205	0.226	0.226	0.270	0.270	0.312	0.312	0.343
k (Max)	0.060	0.073	0.073	0.086	0.086	0.099	0.099	0.112	0.112	0.125	0.138	0.138	0.164	0.164	0.190	0.190	0.216
s	0.050	1/16	1/16	5/64	5/64	5/64	5/64	3/32	3/32	3/32	7/64	7/64	9/64	9/64	5/32	5/32	5/32
t (Min)	0.025	0.031	0.031	0.038	0.038	0.044	0.044	0.051	0.051	0.057	0.064	0.064	0.077	0.077	0.090	0.090	0.090
Length/dim	0-80	1-64	1-72	2-56	2-64	3-48	3-56	4-40	4-48	5-40	6-32	6-40	8-32	8-36	10-24	10-32	12-24
1.1/8								■		■	■◆	■	■◆		■◆	■◆	■
1.1/4				■				■		■	■◆	■	■◆		■◆	■◆	■
1.3/8								■		■	■◆		■◆		■◆	■◆	■
1.1/2				■				■		■	■◆		■◆		■	■◆	■
1.5/8																■◆	
1.3/4								■			■		■		■◆	■◆	
1.7/8																	
2								■			■		■		■◆	■◆	
2.1/4											■		■		■	■	
2.3/8																	
2.1/2											■		■		■	■	
2.3/4											■				■	■	
3											■		■		■	■	
3.1/4															■	■	
3.1/2													■		■	■	

CLICK HERE TO RETURN TO THE CONTENTS PAGE



+ 37 064 411 786



Inquiry@invayear.com

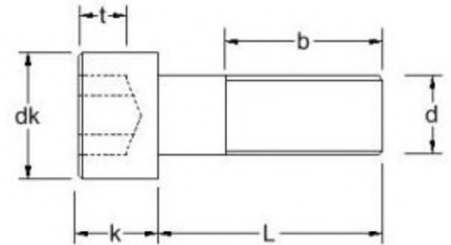
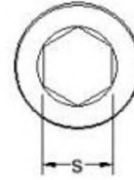

www.invayear.com

SOCKET CAP SCREWS ANSI B18.3

Material grades: A2: ■ A4: ◆

b	1.00 - 1.50	1.00 - 1.50	1.12 - 1.71	1.12 - 1.71	1.25 - 1.94	1.25 - 1.94	1.38 - 2.17	1.38 - 2.17	1.50 - 2.38	1.50 - 2.38	1.75 - 2.82	1.75 - 2.82	2.00 - 3.25	2.00 - 3.25	2.25 - 3.69	2.25 - 3.69	2.50 - 4.12
dk (Max)	0.375	0.375	0.469	0.469	0.562	0.562	0.656	0.656	0.750	0.750	0.938	0.938	1.125	1.125	1.312	1.312	1.500
k (Max)	0.250	0.250	0.312	0.312	0.375	0.375	0.438	0.438	0.500	0.500	0.625	0.625	0.750	0.750	0.875	0.875	1.000
s	3/16	3/16	1/4	1/4	5/16	5/16	3/8	3/8	3/8	3/8	1/2	1/2	5/8	5/8	3/4	3/4	3/4
t (Min)	0.120	0.120	0.151	0.151	0.182	0.182	0.213	0.213	0.245	0.245	0.307	0.307	0.370	0.370	0.432	0.432	0.495
Length/dim	1/4-20	1/4-28	5/16-18	5/16-24	3/8-16	3/8-24	7/16-14	7/16-20	1/2-13	1/2-20	5/8-11	5/8-18	3/4-10	3/4-16	7/8-9	7/8-14	1-8
1.1/8	■◆	■◆															
1.1/4	■◆	■◆	■◆	■◆	■◆	■◆	■◆	■	■◆	■	■◆	■	■◆				
1.3/8	■◆	■◆					■◆	■	■◆	■							
1.1/2	■◆	■◆	■◆	■◆	■◆	■◆	■◆	■	■◆	■◆	■◆	■	■◆	■			
1.5/8																	
1.3/4	■◆	■◆	■◆	■◆	■◆	■	■◆	■	■◆	■◆	■◆	■	■◆	■			
1.7/8		■◆															
2	■◆	■◆	■◆	■◆	■◆	■	■◆	■	■◆	■◆	■◆	■	■◆	■	■	■	■
2.1/4	■◆	■	■◆	■	■◆	■	■◆		■◆	■◆	■◆	■	■◆		■	■	
2.3/8	■◆																
2.1/2	■◆	■	■◆	■	■◆	■	■◆		■◆	■◆	■◆	■	■◆	■	■	■	■
2.3/4	■◆	■	■◆	■	■◆	■	■◆		■◆	■◆	■◆	■	■◆		■	■	
3	■◆	■	■◆	■	■◆	■	■◆		■◆	■◆	■◆	■	■◆	■	■	■	■
3.1/4	■◆	■	■◆	■	■◆	■			■◆	■◆	■◆	■	■◆				
3.1/2	■◆	■	■◆	■	■◆	■	■◆		■◆	■◆	■◆	■	■◆	■	■	■	■

[CLICK HERE TO RETURN TO THE CONTENTS PAGE](#)

+ 37 064 411 786

Inquiry@invayear.com

www.invayear.com

SOCKET CAP SCREWS ANSI B18.3

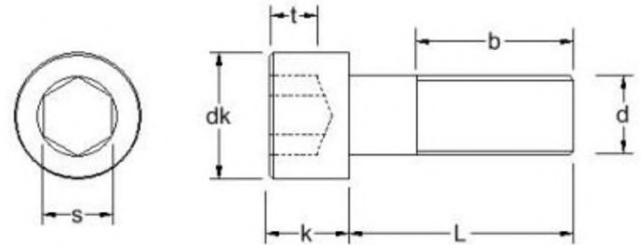

Material grades: A2: ■

b	0.50	0.99	0.62	0.99	0.62	0.99	0.62	0.99	0.62	0.99	0.62	0.99	0.75	0.99	0.75	1.00	0.75	1.05	0.75	1.05	0.88	1.19	0.88	1.19	0.88	1.27	0.88	1.27
dk (Max)	0.096	0.118	0.118	0.140	0.140	0.161	0.161	0.183	0.183	0.205	0.226	0.226	0.270	0.270	0.312	0.312	0.343											
k (Max)	0.060	0.073	0.073	0.086	0.086	0.099	0.099	0.112	0.112	0.125	0.138	0.138	0.164	0.164	0.190	0.190	0.216											
s	0.050	1/16	1/16	5/64	5/64	5/64	5/64	3/32	3/32	3/32	7/64	7/64	9/64	9/64	5/32	5/32	5/32											
t (Min)	0.025	0.031	0.031	0.038	0.038	0.044	0.044	0.051	0.051	0.057	0.064	0.064	0.077	0.077	0.090	0.090	0.090											
Length/dim	0-80	1-64	1-72	2-56	2-64	3-48	3-56	4-40	4-48	5-40	6-32	6-40	8-32	8-36	10-24	10-32	12-24											
3.3/4																												
4																												
4.1/2																												
5																												
5.1/2																												
6																												
7																												
8																												
9																												
10																												
11																												
12																												

CLICK HERE TO RETURN TO THE CONTENTS PAGE



+ 37 064 411 786



Inquiry@invayear.com

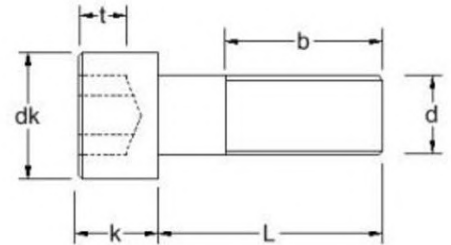

www.invayear.com

SOCKET CAP SCREWS ANSI B18.3

Material grades: A2: ■ A4: ◆

b	1.00 - 1.50	1.00 - 1.50	1.12 - 1.71	1.12 - 1.71	1.25 - 1.94	1.25 - 1.94	1.38 - 2.17	1.38 - 2.17	1.50 - 2.38	1.50 - 2.38	1.75 - 2.82	1.75 - 2.82	2.00 - 3.25	2.00 - 3.25	2.25 - 3.69	2.25 - 3.69	2.50 - 4.12
dk (Max)	0.375	0.375	0.469	0.469	0.562	0.562	0.656	0.656	0.750	0.750	0.938	0.938	1.125	1.125	1.312	1.312	1.500
k (Max)	0.250	0.250	0.312	0.312	0.375	0.375	0.438	0.438	0.500	0.500	0.625	0.625	0.750	0.750	0.875	0.875	1.000
s	3/16	3/16	1/4	1/4	5/16	5/16	3/8	3/8	3/8	3/8	1/2	1/2	5/8	5/8	3/4	3/4	3/4
t (Min)	0.120	0.120	0.151	0.151	0.182	0.182	0.213	0.213	0.245	0.245	0.307	0.307	0.370	0.370	0.432	0.432	0.495
Length/dim	1/4-20	1/4-28	5/16-18	5/16-24	3/8-16	3/8-24	7/16-14	7/16-20	1/2-13	1/2-20	5/8-11	5/8-18	3/4-10	3/4-16	7/8-9	7/8-14	1-8
3.3/4	■	■	◆	■	◆	■			◆	◆							
4	◆	■	◆	■	◆	■	◆		◆	◆	◆	■	◆	■	■	■	■
4.1/2	◆		◆		◆	■			◆	◆	◆	■	◆		■	■	■
5	◆		◆		◆	■			◆	◆	◆	■	◆		■	■	■
5.1/2	◆		◆		◆	■			◆	◆	◆		◆		■	■	
6	◆		◆		◆	■			◆	◆	◆		◆		■	■	■
7	■		■		■				◆		◆		◆		■	■	■
8	■		■		■				◆		◆		◆		■	■	■
9									◆		◆		◆				
10									◆		◆		◆				
11									◆		◆		◆				
12									◆		◆		◆				

CLICK HERE TO RETURN TO THE CONTENTS PAGE



+ 37 064 411 786



Inquiry@invayear.com



www.invayear.com

SOCKET BUTTON SCREWS ANSI B18.3

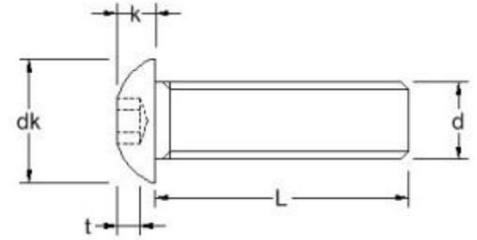

Material grades: A2: ■ A4: ◆

Length/dim	0-80	2-56	4-40	5-40	6-32	8-32	10-24	10-32	1/4-20	1/4-28	5/16-18	5/16-24	3/8-16	3/8-24	1/2-13	1/2-20	5/8-11
1/8	■	■	■		■	■											
3/16	■	■	■	■	■	■		■									
1/4	■	■	◆	■	◆	◆	■	◆	◆	◆							
5/16		■	◆	■	◆	◆	■	◆	◆	■							
3/8	■	■	◆	■	◆	◆	■	◆	◆	◆	■	■					
7/16		■	◆	■	◆		■	◆	◆	■							
1/2	■	■	◆	■	◆	◆	■	◆	◆	◆	◆	■	◆		■		
5/8	■	■	■	■	◆	◆	■	◆	◆	◆	◆	■	◆		■		
3/4	■	■	■	■	◆	◆	■	◆	◆	◆	◆	■	◆	■	◆	■	
7/8		■	■		◆	■	■	◆	◆	■	◆	■	◆	■			
1	■	■	■		◆	◆	■	◆	◆	◆	◆	■	◆	■	◆	■	■
1.1/4			■		■	■	■	■	◆	■	◆	■	◆	■	◆	■	■
1.1/2			■		■	■	■	■	◆	■	◆	■	◆	■	◆	■	■
1.3/4					■	■	■	■	◆	■	◆	■	◆		◆	■	■
2						■	■	■	◆	■	◆	■	◆		◆	■	■
2.1/4							■		◆	■	◆		◆				■
2.1/2							■	■	◆	■	◆		◆		◆	■	■
2.3/4											◆		◆				
3							■	■	◆	■	◆		◆		◆	■	
3.1/2										■	■		■		■		
4										■	■		■		■		
4.1/2															■		
5													■		■		
6													■		■		

[CLICK HERE TO RETURN TO THE CONTENTS PAGE](#)



+ 37 064 411 786



Inquiry@invayear.com

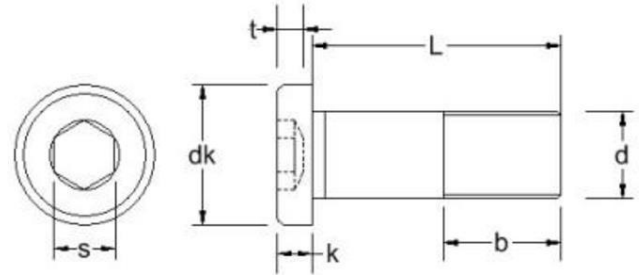

www.invayear.com

LOW HEAD SOCKET CAP SCREWS ANSI B18.3

 Material grades: **A2**

b	0.75 - 1.05	0.88 - 1.19	0.88 - 1.27	0.88 - 1.27	1.00 - 1.50	1.12 - 1.71	1.25 - 1.94											
dk (Max)	0.226	0.270	0.312	0.312	0.375	0.437	0.562											
k (Max)	0.072	0.085	0.098	0.098	0.127	0.158	0.192											
s	1/16	5/64	3/32	3/32	1/8	5/32	3/16											
t (Min)	0.050	0.060	0.072	0.072	0.094	0.110	0.115											
Length/dim	6-32	8-32	10-24	10-32	1/4-20	5/16-18	3/8-16											
1/4	■	■																
3/8	■	■			■													
1/2	■	■	■	■	■	■	■											
5/8	■	■	■	■	■	■	■											
3/4	■	■	■	■	■	■	■											
1	■	■	■	■	■	■	■											
1.1/4			■	■	■	■	■											
1.1/2			■	■	■	■	■											
1.3/4					■	■	■											
2					■	■	■											

CLICK HERE TO RETURN TO THE CONTENTS PAGE



+ 37 064 411 786



Inquiry@invayear.com



www.invayear.com

SOCKET COUNTERSUNK SCREWS ANSI B18.3

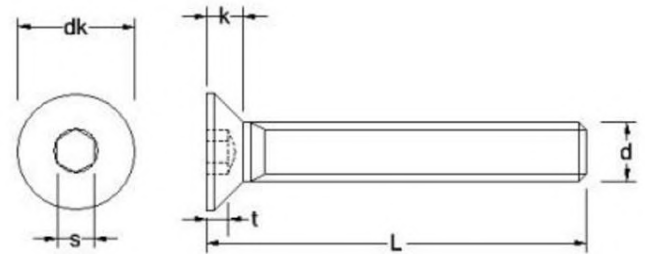

Material grades: A2: ■ A4: ◆

Length/dim	0-80	1-72	2-56	4-40	5-40	6-32	6-40	8-32	10-24	10-32	1/4-20	1/4-28	5/16-18	5/16-24	3/8-16	3/8-24	7/16-14
1/8	■	■	■														
3/16	■	■	■	◆													
1/4	■	■	■	◆	■	◆	■	◆	■	■							
5/16			■	◆	■	◆		◆	■	■							
3/8	■	■	■	◆	■	◆	■	◆	◆	◆	◆	■					
7/16	■	■	■	◆	■	◆		◆	◆	◆	◆	■					
1/2	■	■	■	◆	■	◆	■	◆	◆	◆	◆	◆	◆	■	■		
5/8	■	■	■	◆	■	◆		◆	◆	◆	◆	◆	◆	■	■		
3/4		■	■	◆	■	◆	■	◆	◆	◆	◆	◆	◆	■	◆	■	
7/8			■	■		■		◆	◆	◆	◆	◆	◆	■	◆	■	
1			■	■		■	■	◆	◆	◆	◆	◆	◆	■	◆	■	■
1.1/4				■		■		■	■	◆	◆	■	◆	■	◆	■	■
1.1/2				■		■		■	■	◆	◆	■	◆	■	◆	■	■
1.3/4						■		■	■	■	◆	■	◆	■	◆	■	■
2						■		■	■	■	◆	■	◆	■	◆	■	■
2.1/4											◆	■	◆	■	◆	■	■

CLICK HERE TO RETURN TO THE CONTENTS PAGE



+ 37 064 411 786



Inquiry@invayear.com

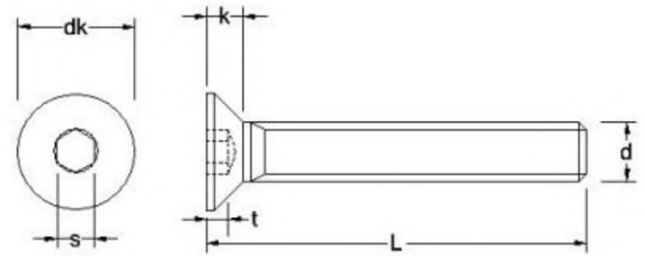

www.invayear.com

SOCKET COUNTERSUNK SCREWS ANSI B18.3

Material grades: A2: ■ A4: ◆

dk (Max)	0.938	0.938	1.188	1.438	1.688													
k (Max)	0.251	0.251	0.324	0.396	0.468													
s	5/16	5/16	3/8	1/2	9/16													
t (Min)	0.172	0.172	0.220	0.220	0.248													
Length/dim	1/2-13	1/2-20	5/8-11	3/4-10	7/8-9													
1/8																		
3/16																		
1/4																		
5/16																		
3/8																		
7/16																		
1/2																		
5/8																		
3/4	■ ◆	■																
7/8	■ ◆	■																
1	■ ◆	■	■ ◆	◆														
1.1/4	■ ◆	■	■ ◆	■ ◆														
1.1/2	■ ◆	■	■ ◆	■ ◆														
1.3/4	■ ◆	■	■ ◆	■ ◆														
2	■ ◆	■	■ ◆	■ ◆														
2.1/4	■ ◆	■																

CLICK HERE TO RETURN TO THE CONTENTS PAGE



+ 37 064 411 786



Inquiry@invayear.com



www.invayear.com

SOCKET COUNTERSUNK SCREWS ANSI B18.3

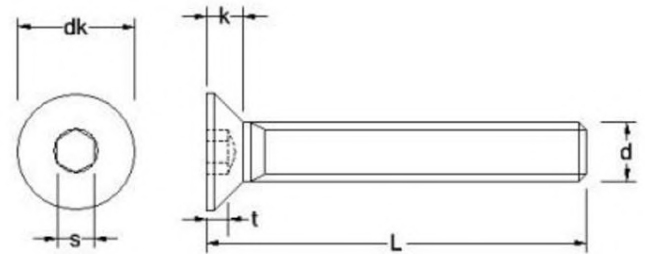

Material grades: A2: ■ A4: ◆

Length/dim	0-80	1-72	2-56	4-40	5-40	6-32	6-40	8-32	10-24	10-32	1/4-20	1/4-28	5/16-18	5/16-24	3/8-16	3/8-24	7/16-14
2.1/2									■	■	■◆	■	■◆	■	■◆	■	■
2.3/4															■◆	■	■
3									■	■	■◆	■	■◆	■	■◆	■	■
3.1/2									■	■	■	■	■◆	■	■◆	■	■
4									■	■	■	■	■◆	■	■◆	■	■
4.1/2											■		■		■◆		
5											■		■		■◆		
5.1/2																	
6											■		■		■◆		
7															■		
8															■		
9															■		
10															■		

CLICK HERE TO RETURN TO THE CONTENTS PAGE



+ 37 064 411 786



Inquiry@invayear.com

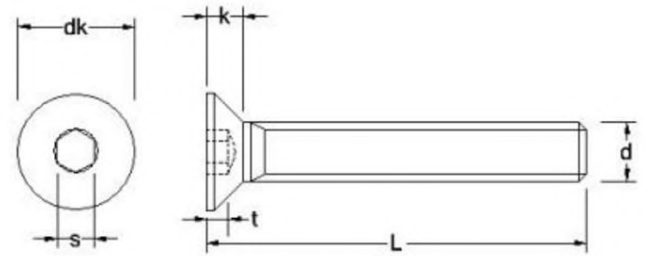

www.invayear.com

SOCKET COUNTERSUNK SCREWS ANSI B18.3

Material grades: A2: ■ A4: ◆

dk (Max)	0.938	0.938	1.188	1.438	1.688															
k (Max)	0.251	0.251	0.324	0.396	0.468															
s	5/16	5/16	3/8	1/2	9/16															
t (Min)	0.172	0.172	0.220	0.220	0.248															
Length/dim	1/2-13	1/2-20	5/8-11	3/4-10	7/8-9															
2.1/2	■◆	■	■◆	■◆																
2.3/4																				
3	■◆	■	■◆	■◆	■															
3.1/2	■◆		■◆	■◆	■															
4	■◆		■◆	■◆	■															
4.1/2	■		■																	
5	■		■	■	■															
5.1/2	■																			
6	■		■	■	■															
7	■																			
8	■																			
9	■																			
10	■																			

CLICK HERE TO RETURN TO THE CONTENTS PAGE



+ 37 064 411 786



Inquiry@invayear.com



www.invayear.com

SOCKET SET SCREWS CUP POINT ANSI B18.3

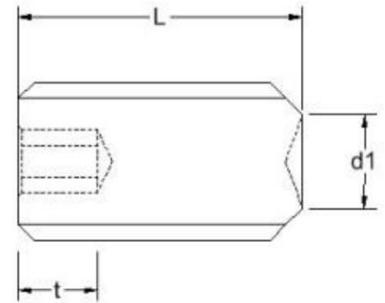
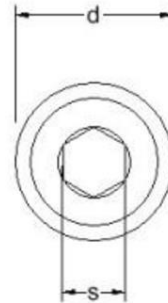

Material grades: A2: ■ A4: ◆

d1 (Max)	0.033	0.040	0.047	0.054	0.054	0.061	0.061	0.067	0.074	0.074	0.087	0.087	0.102	0.102	0.132	0.132	0.172
s	0.028	0.028	0.035	0.050	0.050	0.050	0.050	1/16	1/16	1/16	5/64	5/64	3/32	3/32	1/8	1/8	5/32
t (Min)	0.050	0.060	0.060	0.070	0.070	0.070	0.070	0.080	0.080	0.080	0.090	0.090	0.100	0.100	0.125	0.125	0.156
Length/dim	0-80	1-72	2-56	3-48	3-56	4-40	4-48	5-40	6-32	6-40	8-32	8-36	10-24	10-32	1/4-20	1/4-28	5/16-18
1/16		■	◆														
3/32	■	■	◆	■	■	◆	■										
1/8	■	■	◆	■	■	◆	■	■	◆	■	◆	■	◆	◆			
5/32	■					◆	■										
3/16	■	■	◆	■	■	◆	■	■	◆	■	◆	■	◆	◆	◆	◆	
7/32	■																
1/4	■	■	◆	■	■	◆	■	■	◆	■	◆	■	◆	◆	◆	◆	◆
5/16	■	■	◆	■	■	◆	■	■	◆	■	◆	■	◆	◆	◆	◆	◆
3/8	■	■	◆	■	■	◆	■	■	◆	■	◆	■	◆	◆	◆	◆	◆
7/16	■		■	■	■	◆	■	■	◆	■	◆	■	◆	◆	◆	◆	◆
1/2	■		■	■	■	◆	■	■	◆	■	◆	■	◆	◆	◆	◆	◆
5/8			■			◆	■	■	◆	■	◆	■	◆	◆	◆	◆	◆
3/4			■			◆	■	■	◆	■	◆	■	◆	◆	◆	◆	◆
7/8			■			■	■	■	◆	■	◆	■	◆	◆	◆	◆	◆
1			■			■	■	■	◆	■	◆	■	◆	◆	◆	◆	◆
1.1/4						■			◆		◆		◆	◆	◆	■	◆
1.1/2						■			◆		◆		◆	◆	◆	■	◆
1.3/4									■		■		■	■	◆	■	◆
2									■		■		■	■	◆	■	◆
2.1/2															■		■
3															■		■
3.1/2																	■
4																	■

CLICK HERE TO RETURN TO THE CONTENTS PAGE



+ 37 064 411 786



Inquiry@invayear.com

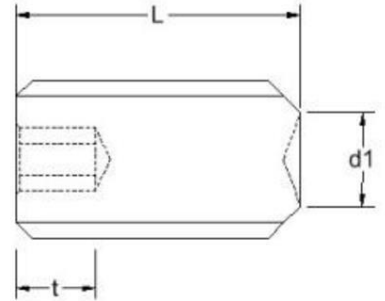
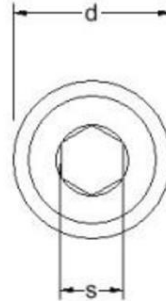

www.invayear.com

SOCKET SET SCREWS CUP POINT ANSI B18.3

Material grades: A2: ■ A4: ◆

d1 (Max)	0.172	0.212	0.212	0.252	0.252	0.291	0.291	0.371	0.450										
s	5/32	3/16	3/16	7/32	7/32	1/4	1/4	5/16	3/8										
t (Min)	0.156	0.188	0.188	0.219	0.219	0.250	0.250	0.312	0.375										
Length/dim	5/16-24	3/8-16	3/8-24	7/16-14	7/16-20	1/2-13	1/2-20	5/8-11	3/4-10										
1/16																			
3/32																			
1/8																			
5/32																			
3/16																			
7/32																			
1/4	■◆	■◆	■◆																
5/16	■◆	■◆	■◆																
3/8	■◆	■◆	■◆	■	■	■◆	■◆												
7/16	■◆	■◆	■◆	■	■														
1/2	■◆	■◆	■◆	■	■	■◆	■◆	■◆											
5/8	■◆	■◆	■◆	■	■	■◆	■◆	■◆	■◆	■◆									
3/4	■◆	■◆	■◆	■	■	■◆	■◆	■◆	■◆	■◆									
7/8	■◆	■◆	■◆	■	■	■◆	■◆	■◆	■◆	■◆									
1	■◆	■◆	■◆	■	■	■◆	■◆	■◆	■◆	■◆									
1.1/4	■	■◆	■	■	■	■◆	■◆	■◆	■◆	■◆									
1.1/2	■	■◆	■	■	■	■◆	■◆	■◆	■◆	■◆									
1.3/4	■	■◆	■	■	■	■◆	■			■◆									
2	■	■◆	■	■	■	■◆	■	■◆	■◆	■◆									
2.1/2		■				■	■	■◆	■◆	■◆									
3		■				■	■	■◆	■◆	■◆									
3.1/2		■				■				■◆									
4		■				■				■◆									

[CLICK HERE TO RETURN TO THE CONTENTS PAGE](#)

+ 37 064 411 786

Inquiry@invayear.com

www.invayear.com

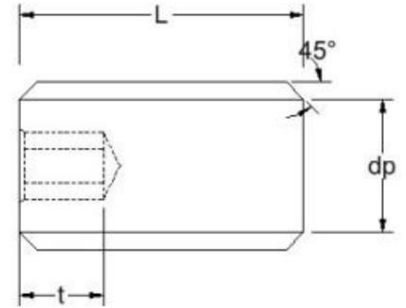
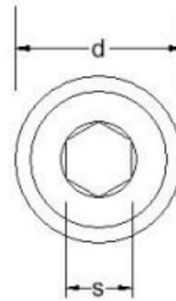
SOCKET SET SCREWS FLAT POINT ANSI B18.3

Material grades: A2: ■ A4: ◆

dp(Max)	0.047	0.061	0.074	0.087	0.102	0.102	0.132	0.132	0.172	0.212								
s	0.035	0.050	1/16	5/64	3/32	3/32	1/8	1/8	5/32	3/16								
t (Min)	0.060	0.070	0.080	0.090	0.100	0.100	0.125	0.125	0.156	0.188								
Length/dim	2-56	4-40	6-32	8-32	10-24	10-32	1/4-20	1/4-28	5/16-18	3/8-16								
1/8	■	◆	◆	◆														
3/16	■	◆	◆	◆	◆	◆												
1/4	■	◆	◆	◆	◆	◆	◆	◆										
5/16	■	◆	◆	◆	◆	◆	◆	◆	◆									
3/8	■	◆	◆	◆	◆	◆	◆	◆	◆	◆								
7/16		◆	◆	◆	◆	◆	◆	◆	◆	◆	◆							
1/2		◆	◆	◆	◆	◆	◆	◆	◆	◆	◆	◆						
5/8			◆	◆	◆	◆	◆	◆	◆	◆	◆	◆	◆					
3/4			◆	◆	◆	◆	◆	◆	◆	◆	◆	◆	◆	◆				
7/8				■	■	■	◆	◆										
1				■	■	■	◆	◆	■	■								
1.1/4							■		■	■								
1.1/2							■		■	■								
1.3/4										■								
2										■								

[CLICK HERE TO RETURN TO THE CONTENTS PAGE](#)



+ 37 064 411 786



Inquiry@invayear.com

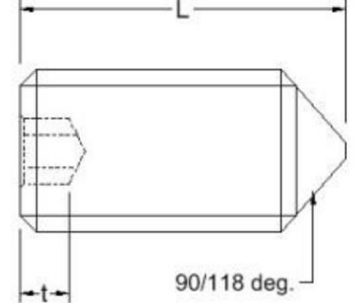
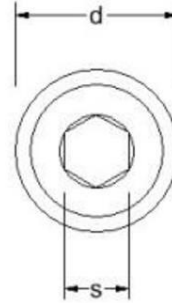

www.invayear.com

SOCKET SET SCREWS CONE POINT ANSI B18.3

Material grades: A2: ■ A4: ◆

LI *	0.13	0.13	0.19	0.19	0.19	0.25	0.25	0.25	0.31	0.31	0.38	0.38	0.44	0.44				
s	0.035	0.050	0.050	1/16	1/16	5/64	3/32	3/32	1/8	1/8	5/32	5/32	3/16	3/16				
t (Min)	0.060	0.070	0.070	0.080	0.080	0.090	0.100	0.100	0.125	0.125	0.156	0.156	0.188	0.188				
Length/dim	2-56	3-48	4-40	5-40	6-32	8-32	10-24	10-32	1/4-20	1/4-28	5/16-18	5/16-24	3/8-16	3/8-24				
1/8	■◆	■	■◆															
3/16	■◆	■	■◆	■	■◆	■◆												
1/4	■◆	■	■◆	■	■◆	■◆	■◆	■◆	■◆	■◆								
5/16	■◆	■	■◆	■	■◆	■◆	■◆	■◆	■◆	■◆	■◆	■						
3/8	■◆	■	■◆	■	■◆	■◆	■◆	■◆	■◆	■◆	■◆	■	■◆	■				
7/16			■◆		■◆	■◆	■◆	■◆	■◆	■◆	■◆	■	■◆	■				
1/2			■◆		■◆	■◆	■◆	■◆	■◆	■◆	■◆	■	■◆	■				
5/8					■◆	■◆	■◆	■◆	■◆	◆	■◆	■	■◆	■				
3/4					■◆	■◆	■◆	■◆	■◆	◆	■◆	■	■◆	■				
7/8							◆	◆	■◆	◆	■◆	■	■◆	■				
1							◆	◆	■◆	◆	■◆	■	■◆	■				
1.1/4									■◆		■◆		■◆					
1.1/2									■◆		■◆		■◆					
1.3/4											◆		■◆					
2											◆		■◆					

CLICK HERE TO RETURN TO THE CONTENTS PAGE



+ 37 064 411 786



Inquiry@invayear.com

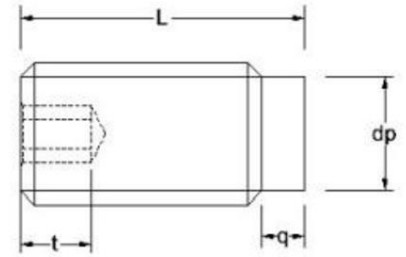
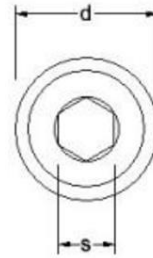

www.invayear.com

 Material grades: **A2**

dp (Max)	0.057	0.075	0.092	0.109	0.127	0.127	0.156	0.203	0.250										
q (Max)	0.024	0.030	0.038	0.043	0.049	0.049	0.067	0.082	0.099										
s	0.035	0.050	1/16	5/64	3/32	3/32	1/8	5/32	3/16										
t (Min)	0.060	0.070	0.080	0.090	0.100	0.100	0.125	0.156	0.188										
Length/dim	2-56	4-40	6-32	8-32	10-24	10-32	1/4-20	5/16-18	3/8-16										
1/8	■	■																	
3/16	■	■	■	■															
1/4	■	■	■	■	■	■	■												
5/16	■	■	■	■	■	■	■	■											
3/8	■	■	■	■	■	■	■	■	■										
7/16		■	■	■	■	■	■	■	■										
1/2		■	■	■	■	■	■	■	■										
5/8			■	■	■	■	■	■	■										
3/4			■	■	■	■	■	■	■										
7/8				■	■	■	■	■	■										
1				■	■	■	■	■	■										
1.1/4							■	■	■										
1.1/2							■	■	■										
1.3/4							■	■	■										
2							■	■	■										

CLICK HERE TO RETURN TO THE CONTENTS PAGE



+ 37 064 411 786



Inquiry@invayear.com

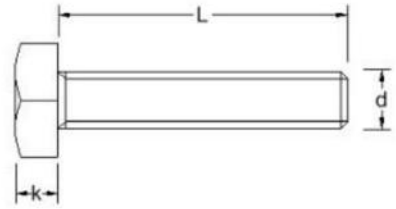

www.invayear.com

HEXAGON HEAD SET SCREWS DIN 933

Material grades: A2: ■ A4: ◆ A4-80: *

k (Max)	1.6	2	2.1	2.9	3.6	4.1	5.4	6.6	7.7	9	10.1	11.7	12.7	14.2	14.78	16.65	19.1
Pitch	0.4	0.45	0.5	0.7	0.8	1.0	1.25	1.5	1.75	2.0	2.0	2.5	2.5	2.5	3.0	3.0	3.5
s	4	5	5.5	7	8	10	13	17	19	22	24	27	30	32	36	41	46
Length/dim	M2	M2.5	M3	M4	M5	M6	M8	M10	M12	M14	M16	M18	M20	M22	M24	M27	M30
3	◆	◆	◆														
4	◆	◆	◆	◆													
5	◆	◆	◆	◆	◆												
6	◆	◆	◆	◆*	◆	◆											
8	◆	◆	◆	◆*	◆*	◆*	◆										
10	◆	◆	◆	◆*	◆*	◆*	◆*	◆									
12	◆	◆	◆	◆*	◆*	◆*	◆*	◆*	◆								
14	◆	◆	◆	◆*	◆*	◆*	◆	◆	◆								
16	◆	◆	◆	◆*	◆*	◆*	◆*	◆*	◆*	◆							
18	◆	◆	◆	◆*	◆*	◆*	◆*	◆*	◆	◆							
20	◆	◆	◆	◆*	◆*	◆*	◆*	◆*	◆*	◆*	◆						
22			◆	◆*	◆*	◆*	◆*	◆*	◆	◆							
25			◆	◆*	◆*	◆*	◆*	◆*	◆*	◆*	◆*	◆	◆				
28							■										
30			◆	◆*	◆*	◆*	◆*	◆*	◆*	◆*	◆*	◆*	◆*	◆	◆	◆	◆
35			◆	◆*	◆*	◆*	◆*	◆*	◆*	◆*	◆*	◆*	◆*	◆	◆	◆	◆
40			◆	◆*	◆*	◆*	◆*	◆*	◆*	◆*	◆*	◆*	◆*	◆	◆	◆	◆*

CLICK HERE TO RETURN TO THE CONTENTS PAGE



+ 37 064 411 786



Inquiry@invayear.com



www.invayear.com

HEXAGON HEAD SET SCREWS DIN 933

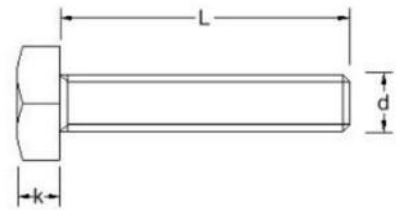

Material grades: A2: ■ A4: ◆ A4-80: *

k (Max)	1.6	2	2.1	2.9	3.6	4.1	5.4	6.6	7.7	9	10.1	11.7	12.7	14.2	14.78	16.65	19.1
Pitch	0.4	0.45	0.5	0.7	0.8	1.0	1.25	1.5	1.75	2.0	2.0	2.5	2.5	2.5	3.0	3.0	3.5
s	4	5	5.5	7	8	10	13	17	19	22	24	27	30	32	36	41	46
Length/dim	M2	M2.5	M3	M4	M5	M6	M8	M10	M12	M14	M16	M18	M20	M22	M24	M27	M30
45			◆	◆*	◆*	◆*	◆*	◆*	◆*	◆*	◆*	◆*	◆*	◆*	◆*		
50			◆	◆*	◆*	◆*	◆*	◆*	◆*	◆*	◆*	◆*	◆*	◆*	◆*	◆*	◆*
55				◆*	◆*	◆*	◆*	◆*	◆*	◆*	◆*	◆*	◆*	◆*	◆*	◆*	◆*
60				◆*	◆*	◆*	◆*	◆*	◆*	◆*	◆*	◆*	◆*	◆*	◆*	◆*	◆*
65				◆*	◆*	◆*	◆*	◆*	◆*	◆*	◆*	◆*	◆*	◆*	◆*	◆*	◆*
70				◆*	◆*	◆*	◆*	◆*	◆*	◆*	◆*	◆*	◆*	◆*	◆*	◆*	◆*
75				◆*	◆*	◆*	◆*	◆*	◆*	◆*	◆*	◆*	◆*	◆*	◆*	◆*	◆*
80				◆*	◆*	◆*	◆*	◆*	◆*	◆*	◆*	◆*	◆*	◆*	◆*	◆*	◆*
85					◆*	◆*	◆*	◆*	◆*	◆*	◆*	◆*	◆*	◆*	◆*	◆*	◆*
90					◆*	◆*	◆*	◆*	◆*	◆*	◆*	◆*	◆*	◆*	◆*	◆*	◆*
95					◆*	◆*	◆*	◆*	◆*	◆*	◆*	◆*	◆*	◆*	◆*	◆*	◆*
100					◆*	◆*	◆*	◆*	◆*	◆*	◆*	◆*	◆*	◆*	◆*	◆*	◆*
110						◆*	◆*	◆*	◆*	◆*	◆*	◆*	◆*	◆*	◆*	◆*	◆*
120						◆*	◆*	◆*	◆*	◆*	◆*	◆*	◆*	◆*	◆*	◆*	◆*
130						◆*	◆*	◆*	◆*	◆*	◆*	◆*	◆*	◆*	◆*	◆*	◆*
140						◆*	◆*	◆*	◆*	◆*	◆*	◆*	◆*	◆*	◆*	◆*	◆*
150						◆*	◆*	◆*	◆*	◆*	◆*	◆*	◆*	◆*	◆*	◆*	◆*

CLICK HERE TO RETURN TO THE CONTENTS PAGE



+ 37 064 411 786



Inquiry@invayear.com

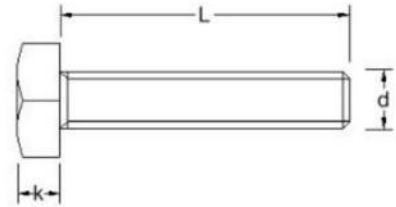

www.invayear.com

HEXAGON HEAD SET SCREWS DIN 933

Material grades: A2:■ A4:◆ A4-80:★

k (Max)	1.6	2	2.1	2.9	3.6	4.1	5.4	6.6	7.7	9	10.1	11.7	12.7	14.2	14.78	16.65	19.1
Pitch	0.4	0.45	0.5	0.7	0.8	1.0	1.25	1.5	1.75	2.0	2.0	2.5	2.5	2.5	3.0	3.0	3.5
s	4	5	5.5	7	8	10	13	17	19	22	24	27	30	32	36	41	46
Length/dim	M2	M2.5	M3	M4	M5	M6	M8	M10	M12	M14	M16	M18	M20	M22	M24	M27	M30
160							◆ ★	◆ ★	◆ ★		◆ ★		◆ ★		◆ ★	◆	◆
170							◆ ★	◆ ★	◆ ★		◆ ★		◆ ★		◆ ★	◆	◆
180							◆ ★	◆ ★	◆ ★		◆ ★		◆ ★		◆ ★	◆	◆
190							◆ ★	◆ ★	◆ ★		◆ ★		◆ ★		◆ ★	◆	◆
200							◆ ★	◆ ★	◆ ★		◆ ★		◆ ★		◆ ★	◆	◆

[CLICK HERE TO RETURN TO THE CONTENTS PAGE](#)

+ 37 064 411 786

Inquiry@invayear.com

www.invayear.com

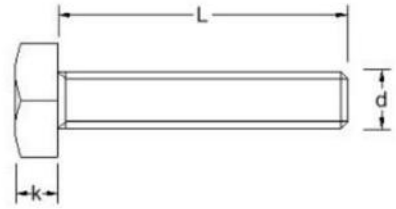
HEXAGON HEAD SET SCREWS DIN 933

Material grades: A2: ■ A4: ◆

k (Max)	21.4	22.92																
Pitch	3.5	4.0																
s	50	55																
Length/dim	M33	M36																
160	■◆	■◆																
170	■◆	■◆																
180	■◆	■◆																
190	■◆	■◆																
200	■◆	■◆																

[CLICK HERE TO RETURN TO THE CONTENTS PAGE](#)



+ 37 064 411 786



Inquiry@invayear.com



www.invayear.com

HEXAGON HEAD BOLTS DIN 931

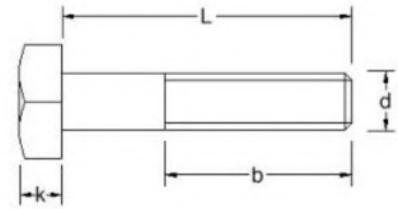

Material grades: A2: ■ A4: ◆ A4-80: *

b (Max)	16	18	22	26	30	34	38	42	46	50	54	60	66	72	78		
b (Max) (L > 125mm)	22	24	28	32	36	40	44	48	52	56	56	66	72	78	90		
k (Min)	3.35	3.85	5.15	6.22	7.32	8.62	9.82	11.28	12.28	13.78	14.78	16.65	18.28	20.58	22.1		
Pitch	0.8	1.0	1.25	1.5	1.75	2.0	2.0	2.5	2.5	2.5	3.0	3.0	3.5	3.5	4.0		
s	8	10	13	17	19	22	24	27	30	34	36	41	46	50	55		
Length/dim	M5	M6	M8	M10	M12	M14	M16	M18	M20	M22	M24	M27	M30	M33	M36		
25	■ ◆ *																
30	■ ◆ *	■ ◆ *	■ ◆ *														
35	■ ◆ *	■ ◆ *	■ ◆ *	■ ◆													
40	■ ◆ *	■ ◆ *	■ ◆ *	■ ◆ *	■ ◆ *	■ ◆ *											
45	■ ◆ *	■ ◆ *	■ ◆ *	■ ◆ *	■ ◆ *	■ ◆ *											
50	■ ◆ *	■ ◆ *	■ ◆ *	■ ◆ *	■ ◆ *	■ ◆ *	■ ◆ *	■ ◆ *	■ ◆ *								
55	■ ◆ *	■ ◆ *	■ ◆ *	■ ◆ *	■ ◆ *	■ ◆ *	■ ◆ *	■ ◆ *	■ ◆ *								
60	■ ◆ *	■ ◆ *	■ ◆ *	■ ◆ *	■ ◆ *	■ ◆ *	■ ◆ *	■ ◆ *	■ ◆ *	■ ◆	■ ◆ *						
65	■ ◆ *	■ ◆ *	■ ◆ *	■ ◆ *	■ ◆ *	■ ◆ *	■ ◆ *	■ ◆ *	■ ◆ *	■ ◆	■ ◆ *						
70	■ ◆ *	■ ◆ *	■ ◆ *	■ ◆ *	■ ◆ *	■ ◆ *	■ ◆ *	■ ◆ *	■ ◆ *	■ ◆	■ ◆ *	■ ◆	■ ◆ *				
75	■ ◆ *	■ ◆ *	■ ◆ *	■ ◆ *	■ ◆ *	■ ◆ *	■ ◆ *	■ ◆ *	■ ◆ *	■ ◆	■ ◆ *	■ ◆	■ ◆ *				
80	■ ◆ *	■ ◆ *	■ ◆ *	■ ◆ *	■ ◆ *	■ ◆ *	■ ◆ *	■ ◆ *	■ ◆ *	■ ◆	■ ◆ *	■ ◆	■ ◆ *	■ ◆	■ ◆		
85	■ ◆ *	■ ◆ *	■ ◆ *	■ ◆ *	■ ◆ *	■ ◆ *	■ ◆ *	■ ◆ *	■ ◆ *	■ ◆	■ ◆ *	■ ◆	■ ◆ *	■ ◆	■ ◆		
90	■ ◆ *	■ ◆ *	■ ◆ *	■ ◆ *	■ ◆ *	■ ◆ *	■ ◆ *	■ ◆ *	■ ◆ *	■ ◆	■ ◆ *	■ ◆	■ ◆ *	■ ◆	■ ◆	■ ◆	
95	■ ◆ *	■ ◆ *	■ ◆ *	■ ◆ *	■ ◆ *	■ ◆ *	■ ◆ *	■ ◆ *	■ ◆ *	■ ◆	■ ◆ *	■ ◆	■ ◆ *	■ ◆	■ ◆	■ ◆	

CLICK HERE TO RETURN TO THE CONTENTS PAGE



+ 37 064 411 786



Inquiry@invayear.com

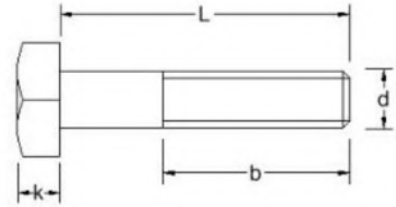

www.invayear.com

HEXAGON HEAD BOLTS DIN 931

Material grades: A2: ■ A4: ◆ A4-80: *

b (Max)	16	18	22	26	30	34	38	42	46	50	54	60	66	72	78				
b (Max) (L > 125mm)	22	24	28	32	36	40	44	48	52	56	56	66	72	78	90				
k (Min)	3.35	3.85	5.15	6.22	7.32	8.62	9.82	11.28	12.28	13.78	14.78	16.65	18.28	20.58	22.1				
Pitch	0.8	1.0	1.25	1.5	1.75	2.0	2.0	2.5	2.5	2.5	3.0	3.0	3.5	3.5	4.0				
s	8	10	13	17	19	22	24	27	30	34	36	41	46	50	55				
Length/dim	M5	M6	M8	M10	M12	M14	M16	M18	M20	M22	M24	M27	M30	M33	M36				
100	■◆*	■◆*	■◆*	■◆*	■◆*	■◆*	■◆*	■◆	■◆*	■◆	■◆*	■◆	■◆	■◆	■◆				
105				■											■◆				
110		■◆*	■◆*	■◆*	■◆*	■◆*	■◆*	■◆	■◆*	■◆	■◆*	■◆	■◆	■◆	■◆				
120		■◆*	■◆*	■◆*	■◆*	■◆*	■◆*	■◆	■◆*	■◆	■◆*	■◆	■◆	■◆	■◆				
130		■◆*	■◆*	■◆*	■◆*	■◆*	■◆*	■◆	■◆*	■◆	■◆*	■◆	■◆	■◆	■◆				
140		■◆*	■◆*	■◆*	■◆*	■◆*	■◆*	■◆	■◆*	■◆	■◆*	■◆	■◆	■◆	■◆				
150		■◆*	■◆*	■◆*	■◆*	■◆*	■◆*	■◆	■◆*	■◆	■◆*	■◆	■◆	■◆	■◆				
160		■◆	■◆*	■◆*	■◆*	■◆*	■◆*		■◆*	■◆	■◆*	■◆	■◆	■◆	■◆				
170		■◆	■◆*	■◆*	■◆*	■◆*	■◆*	■◆	■◆*	■◆	■◆*	■◆	■◆	■◆	■◆				
180		■◆	■◆*	■◆*	■◆*	■◆*	■◆*	■◆	■◆*	■◆	■◆*	■◆	■◆	■◆	■◆				
190		■◆	■◆*	■◆*	■◆*	■◆*	■◆*	■◆	■◆*	■◆	■◆*	■◆	■◆	■◆	■◆				
200		■◆	■◆*	■◆*	■◆*	■◆*	■◆*	■◆	■◆*	■◆	■◆*	■◆	■◆	■◆	■◆				
210			■◆	■◆*	■◆*		■◆*		■◆*		■◆*	■◆	■◆	■◆	■◆				
220			■◆	■◆*	■◆*		■◆*		■◆*		■◆*	■◆	■◆	■◆	■◆				
230			■◆	■◆*	■◆*		■◆*		■◆*		■◆*	■◆	■◆	■◆	■◆				

CLICK HERE TO RETURN TO THE CONTENTS PAGE



+ 37 064 411 786



Inquiry@invayear.com



www.invayear.com

HEXAGON HEAD BOLTS DIN 931

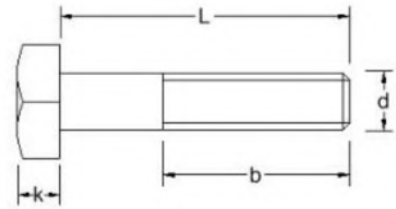

Material grades: A2: ■ A4: ◆ A4-80: *

b (Max)	16	18	22	26	30	34	38	42	46	50	54	60	66	72	78		
b (Max) (L > 125mm)	22	24	28	32	36	40	44	48	52	56	56	66	72	78	90		
k (Min)	3.35	3.85	5.15	6.22	7.32	8.62	9.82	11.28	12.28	13.78	14.78	16.65	18.28	20.58	22.1		
Pitch	0.8	1.0	1.25	1.5	1.75	2.0	2.0	2.5	2.5	2.5	3.0	3.0	3.5	3.5	4.0		
s	8	10	13	17	19	22	24	27	30	34	36	41	46	50	55		
Length/dim	M5	M6	M8	M10	M12	M14	M16	M18	M20	M22	M24	M27	M30	M33	M36		
240			◆ ◆	◆ ◆ *	◆ ◆ *		◆ ◆ *		◆ ◆ *		◆ ◆ *	◆ ◆	◆ ◆	◆ ◆	◆ ◆		
250			◆ ◆	◆ ◆ *	◆ ◆ *		◆ ◆ *		◆ ◆ *		◆ ◆ *	◆ ◆	◆ ◆	◆ ◆	◆ ◆		
260			◆ ◆	◆ ◆	◆ ◆		◆ ◆		◆ ◆		◆ ◆	◆ ◆	◆ ◆	◆ ◆	◆ ◆		
270			◆ ◆	◆ ◆	◆ ◆		◆ ◆		◆ ◆		◆ ◆	◆ ◆	◆ ◆	◆ ◆	◆ ◆		
280			◆ ◆	◆ ◆	◆ ◆		◆ ◆		◆ ◆		◆ ◆	◆ ◆	◆ ◆	◆ ◆	◆ ◆		
290			◆ ◆	◆ ◆	◆ ◆		◆ ◆		◆ ◆		◆ ◆	◆ ◆	◆ ◆	◆ ◆	◆ ◆		
300			◆ ◆	◆ ◆	◆ ◆		◆ ◆		◆ ◆		◆ ◆	◆ ◆	◆ ◆	◆ ◆	◆ ◆		
320				◆ ◆	■		◆ ◆		◆ ◆		◆ ◆						
340				◆ ◆	■		◆ ◆		◆ ◆		◆ ◆						
360				◆ ◆	■		◆ ◆		◆ ◆		◆ ◆						
380				◆ ◆	■		◆ ◆		◆ ◆		◆ ◆						
400				◆ ◆	■		◆ ◆		◆ ◆		◆ ◆						
420				■	■		◆ ◆		◆ ◆		◆ ◆						
440				■	■		◆ ◆		◆ ◆		◆ ◆						
460				■	■		◆ ◆		◆ ◆		◆ ◆						
480				■	■		◆ ◆		◆ ◆		◆ ◆						
500				■	■		◆ ◆		◆ ◆		◆ ◆						
520									■		■						
540									■		■						
560									■		■						
580									■		■						
600									■		■						

[CLICK HERE TO RETURN TO THE CONTENTS PAGE](#)



+ 37 064 411 786



Inquiry@invayear.com

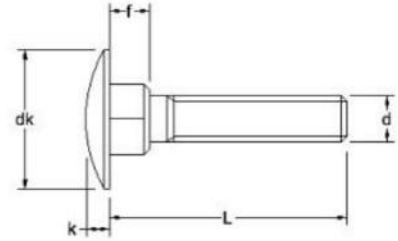
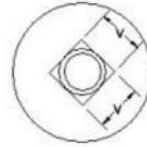

www.invayear.com

CARRIAGE BOLTS FULL THREAD DIN 603

Material grades: A2: ■ A4: ◆

dk	12.45	15.45	19.35	23.35	29.35	37.2													
f (Max)	4.1	4.6	5.6	6.6	8.75	11.1													
k (Min)	2.7	3.12	4.12	4.62	6.05	8.05													
Pitch	0.8	1.0	1.25	1.5	1.75	2.0													
v (Max)	5.48	6.48	8.58	10.58	12.7	15.3													
Length/dim	M5	M6	M8	M10	M12	M16													
12	◆	◆																	
16	◆	◆	◆	◆															
18	◆																		
20	◆	◆	◆	◆															
25	◆	◆	◆	◆	◆														
30	◆	◆	◆	◆	◆	◆													
35	◆	◆	◆	◆	◆	◆													
40	◆	◆	◆	◆	◆	◆													
45	◆	◆	◆	◆	◆	◆													
50	◆	◆	◆	◆	◆	◆													
55	◆	◆	◆	◆	◆	◆													
60	◆	◆	◆	◆	◆	◆													
65	◆	◆	◆	◆	◆	◆													
70	◆	◆	◆	◆	◆	◆													
75	◆	◆	◆	◆	◆	◆													

CLICK HERE TO RETURN TO THE CONTENTS PAGE



+ 37 064 411 786



Inquiry@invayear.com



www.invayear.com

CARRIAGE BOLTS FULL THREAD DIN 603

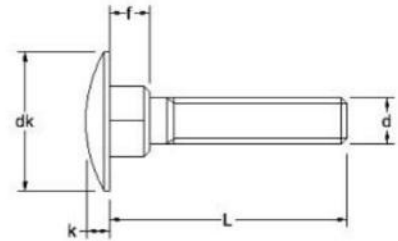
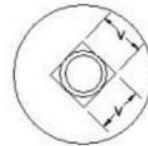

Material grades: A2: ■ A4: ◆

dk	12.45	15.45	19.35	23.35	29.35	37.2												
f (Max)	4.1	4.6	5.6	6.6	8.75	11.1												
k (Min)	2.7	3.12	4.12	4.62	6.05	8.05												
Pitch	0.8	1.0	1.25	1.5	1.75	2.0												
v (Max)	5.48	6.48	8.58	10.58	12.7	15.3												
Length/dim	M5	M6	M8	M10	M12	M16												
80	■◆	■◆	■◆	■◆	■◆	■◆												
85				■◆														
90	■	■◆	■◆	■◆	■◆	■◆												
100	■	■◆	■◆	■◆	■◆	■◆												
110	■	■◆	■◆	■◆	■◆	■◆												
120	■	■◆	■◆	■◆	■◆	■◆												
130		■◆	■◆	■◆	■◆	■◆												
140		■◆	■◆	■◆	■◆	■◆												
150			■◆	■◆	■◆	■◆												
160					■	■												
180				■	■	■												
200				■	■	■												
220					■													
240					■													
260					■													
280					■													
300					■													

[CLICK HERE TO RETURN TO THE CONTENTS PAGE](#)



+ 37 064 411 786



Inquiry@invayear.com

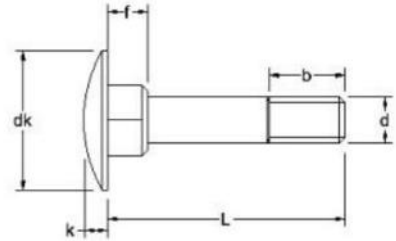
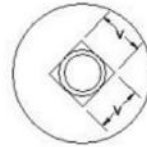

www.invayear.com

CARRIAGE BOLTS DIN 603

Material grades: A2: ■ A4: ◆

	16	18	22	26	36	38												
b (Max)	16	18	22	26	36	38												
dk	12.45	15.45	19.35	23.35	29.35	37.2												
f (Max)	4.1	4.6	5.6	6.6	8.75	11.1												
k (Min)	2.7	3.12	4.12	4.62	6.05	8.05												
Pitch	0.8	1.0	1.25	1.5	1.75	2.0												
v (Max)	5.48	6.48	8.58	10.58	12.7	15.3												
Length/dim	M5	M6	M8	M10	M12	M16												
25	◆	◆																
30	◆	◆	◆															
35	◆	◆	◆	◆														
40	◆	◆	◆	◆	◆	◆												
45	◆	◆	◆	◆	◆	◆												
50	◆	◆	◆	◆	◆	◆												
55	◆	◆	◆	◆	◆	◆												
60	◆	◆	◆	◆	◆	◆												
65	◆	◆	◆	◆	◆	◆												
70	◆	◆	◆	◆	◆	◆												
75	◆	◆	◆	◆	◆	◆												
80	◆	◆	◆	◆	◆	◆												
85				◆														
90		◆	◆	◆	◆	◆												

[CLICK HERE TO RETURN TO THE CONTENTS PAGE](#)



+ 37 064 411 786



Inquiry@invayear.com



www.invayear.com

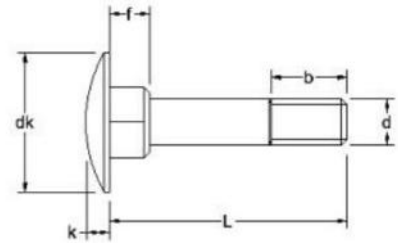
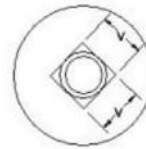

Material grades: A2: ■ A4: ◆

b (Max)	16	18	22	26	36	38													
dk	12.45	15.45	19.35	23.35	29.35	37.2													
f (Max)	4.1	4.6	5.6	6.6	8.75	11.1													
k (Min)	2.7	3.12	4.12	4.62	6.05	8.05													
Pitch	0.8	1.0	1.25	1.5	1.75	2.0													
v (Max)	5.48	6.48	8.58	10.58	12.7	15.3													
Length/dim	M5	M6	M8	M10	M12	M16													
100		■◆	■◆	■◆	■◆	■◆													
110		■◆	■◆	■◆	■◆	■◆													
120		■◆	■◆	■◆	■◆	■◆													
130		■	■◆	■◆	■◆	■◆													
140		■	■◆	■◆	■◆	■◆													
150			■◆	■◆	■◆	■◆													
160			■	■	■	■													
170			■																
180			■	■	■	■													
190			■																
200			■		■	■													
220				■	■	■													
240				■	■	■													
260				■	■	■													
280				■	■	■													
300				■	■	■													

CLICK HERE TO RETURN TO THE CONTENTS PAGE



+ 37 064 411 786



Inquiry@invayear.com

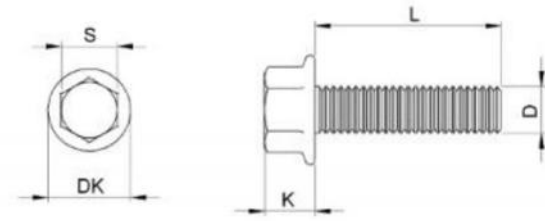

www.invayear.com

FLANGED HEXAGON BOLTS DIN 6921

Material grades: A2:■

dk	11.8	14.2	18	22.3															
k	5.4	6.6	8.1	9.2															
Pitch	0.8	1.0	1.25	1.5															
s	8	10	13	15															
Length/dim	M5	M6	M8	M10															
8/8	■																		
10/10	■	■																	
12/12	■	■	■																
16/16	■	■	■	■															
20/20	■	■	■	■															
25/25	■	■	■	■															
30/30	■	■	■	■															
35/35	■	■	■	■															
40/40	■	■	■	■															
45/45	■	■	■	■															
50/50	■	■	■	■															
55/55		■	■	■															
60/60		■	■	■															
65/65				■															
70/70			■	■															
80/80			■	■															
90/90				■															
100/100				■															

CLICK HERE TO RETURN TO THE CONTENTS PAGE



+ 37 064 411 786



Inquiry@invayear.com

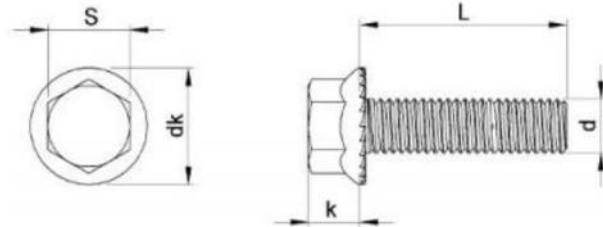

www.invayear.com

SERRATED FLANGED HEXAGON BOLTS DIN 6921

 Material grades: **A2**

dk	11.8	14.2	18	22.3															
k	5.4	6.6	8.1	9.2															
Pitch	0.8	1.0	1.25	1.5															
s	8	10	13	15															
Length/dim	M5	M6	M8	M10															
8/8	■																		
10/10	■	■																	
12/12	■	■	■																
16/16	■	■	■	■															
20/20	■	■	■	■															
25/25	■	■	■	■															
30/30	■	■	■	■															
35/35	■	■	■	■															
40/40	■	■	■	■															
45/45	■	■	■	■															
50/50	■	■	■	■															
55/55		■	■	■															
60/60		■	■	■															
65/65			■	■															
70/70			■	■															
80/80			■	■															
90/90				■															
100/100				■															

[CLICK HERE TO RETURN TO THE CONTENTS PAGE](#)



+ 37 064 411 786



Inquiry@invayear.com

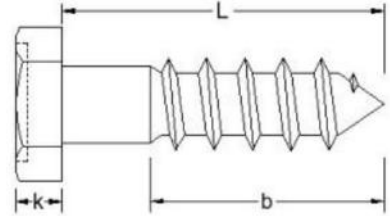

www.invayear.com

HEXAGON HEAD COACH SCREWS DIN 571

Material grades: A2: ■ A4: ◆

b	0.6 x L	0.6 x L	0.6 x L	0.6 x L	0.6 x L	0.6 x L	0.6 x L											
k	3.5	4	5	5.5	7	8	10											
s	8	10	12	13	17	19	24											
Length/dim	5	6	7	8	10	12	16											
20	■	■																
25	■◆	■◆		■◆														
30	■◆	■◆	■◆	■◆														
35	■◆	■◆	■◆	■◆														
40	■◆	■◆	■◆	■◆	■◆													
45	■◆	■◆	■◆	■◆	■◆	■◆												
50	■◆	■◆	■◆	■◆	■◆	■◆	■◆											
55	■◆	■◆	■◆	■◆	■◆	■◆	■◆											
60	■◆	■◆	■◆	■◆	■◆	■◆	■◆	■◆										
65		■◆	■◆	■◆	■◆	■◆	■◆											
70	■◆	■◆	■◆	■◆	■◆	■◆	■◆	■◆										
75				■◆	■◆	■◆	■◆											
80	■	■◆	■◆	■◆	■◆	■◆	■◆	■◆										
90		■◆	■◆	■◆	■◆	■◆	■◆	■◆										
100		■◆	■◆	■◆	■◆	■◆	■◆	■◆										
110		■◆	■◆	■◆	■◆	■◆	■◆	■◆										
120		■◆	■◆	■◆	■◆	■◆	■◆	■◆										

CLICK HERE TO RETURN TO THE CONTENTS PAGE



+ 37 064 411 786



Inquiry@invayear.com

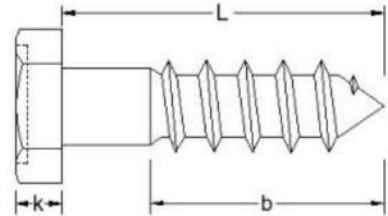

www.invayear.com

HEXAGON HEAD COACH SCREWS DIN 571

Material grades: A2: ■ A4: ◆

b	0.6 x L	0.6 x L	0.6 x L	0.6 x L	0.6 x L	0.6 x L	0.6 x L										
k	3.5	4	5	5.5	7	8	10										
s	8	10	12	13	17	19	24										
Length/dim	5	6	7	8	10	12	16										
130		■ ◆	■ ◆	■ ◆	■ ◆	■ ◆	■ ◆										
140		■	■ ◆	■ ◆	■ ◆	■ ◆	■ ◆										
150			■ ◆	■ ◆	■ ◆	■ ◆	■ ◆										
160			■	■ ◆	■ ◆	■ ◆	■ ◆										
170			■														
180			■	■ ◆	■ ◆	■ ◆	■ ◆										
190			■														
200				■ ◆	■ ◆	■ ◆	■ ◆										
210			■														
220					■	■											
240					■	■											
260					■	■											
280					■	■											
300					■	■											

CLICK HERE TO RETURN TO THE CONTENTS PAGE



+ 37 064 411 786



Inquiry@invayear.com

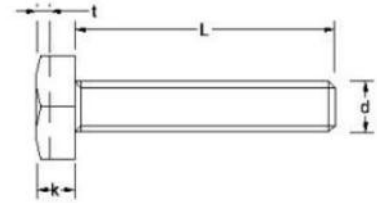
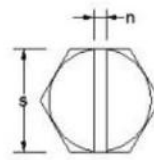

www.invayear.com

SLOTTED HEXAGON HEAD SET SCREW DIN 933SZ

Material grades: A2:■

k (Max)	2.1	3.0	3.5	4.0	5.3	6.4												
n	0.8	1.0	1.2	1.6	2.0	2.0												
Pitch	0.5	0.7	0.8	1.0	1.25	1.5												
s	5.5	7	8	10	13	17												
t	0.8	1.1	1.4	1.6	2.1	2.1												
Length/dim	M3	M4	M5	M6	M8	M10												
5	■	■																
6	■	■	■															
8	■	■	■	■														
10	■	■	■	■	■													
12	■	■	■	■	■	■												
14	■	■	■	■	■	■	■											
16	■	■	■		■	■												
18		■	■	■	■	■	■											
20	■	■	■	■	■	■	■											
22		■	■	■	■	■	■											
25	■	■	■	■	■	■	■											
30	■	■	■	■	■	■	■											
35	■	■	■	■	■	■	■											
40	■	■	■	■	■	■	■											
45	■	■	■	■	■	■	■											
50	■	■	■	■	■	■	■											
55		■	■	■	■	■	■											
60		■	■	■	■	■	■											
65				■	■	■	■											
70			■	■	■	■	■											
75				■	■	■	■											
80				■	■	■	■											

[CLICK HERE TO RETURN TO THE CONTENTS PAGE](#)



+ 37 064 411 786



Inquiry@invayear.com



www.invayear.com

HEXAGON HEAD SET SCREWS ANSI B18.2.1



Material grades: A2: ■ A4: ◆

k (Max)	0.060	0.093	0.110	0.120	0.120	0.155	0.163	0.163	0.211	0.211	0.243	0.243	0.291	0.291	0.323	0.323	0.371
s (Max)	0.188	0.250	0.250	0.312	0.312	0.312	0.438	0.438	0.500	0.500	0.562	0.562	0.625	0.625	0.750	0.750	0.812
Length/dim	4-40	6-32	8-32	10-24	10-32	12-24	1/4-20	1/4-28	5/16-18	5/16-24	3/8-16	3/8-24	7/16-14	7/16-20	1/2-13	1/2-20	9/16-12
1/4	■	■	■		■												
5/16	■	◆	◆	◆	■												
3/8	■	◆	◆	◆	◆		◆	■	■		■						
7/16	■	◆	◆				◆										
1/2	■	◆	◆	◆	◆	■	◆	◆	◆	◆	◆	◆			■	◆	
9/16	■	◆	◆														
5/8	■	◆	◆	◆	◆	■	◆	◆	◆	◆	◆	◆			■		
3/4	■	◆	◆	◆	◆	■	◆	◆	◆	◆	◆	◆	◆	◆	◆	◆	
7/8	■	◆	◆	◆	◆	■	◆	◆	◆	◆	◆	◆		◆	◆	◆	
1	■	◆	◆	◆	◆	■	◆	◆	◆	◆	◆	◆	◆	◆	◆	◆	◆
1.1/8							◆	■	◆	◆	◆	◆			◆		
1.1/4		◆	◆	◆	◆		◆	◆	◆	◆	◆	◆	◆	◆	◆	◆	◆
1.1/2		◆	◆	◆	◆		◆	◆	◆	◆	◆	◆	◆	◆	◆	◆	◆
1.3/4			■	■	■		◆	◆	◆	◆	◆	◆	◆	◆	◆	◆	◆
2			■	■	■		◆	◆	◆	◆	◆	◆	◆	◆	◆	◆	◆
2.1/4				■	■		◆	■	◆	◆	◆	■		◆	◆	■	
2.1/2				■	■		◆	■	◆	◆	◆	■	■	◆	◆	■	
2.3/4					■		◆	■	■		◆	■	◆	◆	◆	■	

CLICK HERE TO RETURN TO THE CONTENTS PAGE



+ 37 064 411 786



Inquiry@invayear.com

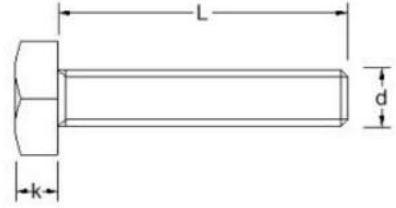

www.invayear.com

HEXAGON HEAD SET SCREWS ANSI B18.2.1

Material grades: A2: ■ A4: ◆

k (Max)	0.371	0.403	0.403	0.483	0.483	0.563	0.563	0.627	0.627								
s (Max)	0.812	0.938	0.938	1.125	1.125	1.312	1.312	1.500	1.500								
Length/dim	9/16-18	5/8-11	5/8-18	3/4-10	3/4-16	7/8-9	7/8-14	1-8	1-12								
1/4																	
5/16																	
3/8																	
7/16																	
1/2																	
9/16																	
5/8																	
3/4		■◆															
7/8																	
1	◆	■◆	■◆	■													
1.1/8																	
1.1/4	◆	■◆	■◆	■◆	◆												
1.1/2	■◆	■◆	■◆	■◆	■◆	■◆	■◆										
1.3/4	■◆	■◆	■◆	■◆	■◆	■◆	■◆	◆	◆								
2	■◆	■◆	■◆	■◆	■◆	■◆	■◆	■◆	■◆								
2.1/4		■◆	◆	■◆		■◆	■◆	■◆	■◆								
2.1/2		◆	◆	■◆		■◆	■◆	■◆	■◆								
2.3/4		■◆		■◆		■◆		■◆	■◆								

CLICK HERE TO RETURN TO THE CONTENTS PAGE



+ 37 064 411 786



Inquiry@invayear.com



www.invayear.com

HEXAGON HEAD SET SCREWS ANSI B18.2.1

Material grades: A2: ■ A4: ◆

k (Max)	0.060	0.093	0.110	0.120	0.120	0.155	0.163	0.163	0.211	0.211	0.243	0.243	0.291	0.291	0.323	0.323	0.371
s (Max)	0.188	0.250	0.250	0.312	0.312	0.312	0.438	0.438	0.500	0.500	0.562	0.562	0.625	0.625	0.750	0.750	0.812
Length/dim	4-40	6-32	8-32	10-24	10-32	12-24	1/4-20	1/4-28	5/16-18	5/16-24	3/8-16	3/8-24	7/16-14	7/16-20	1/2-13	1/2-20	9/16-12
3					■		◆	■	◆	■	◆	■	◆	◆	◆	■	
3.1/4									◆		◆				◆	■	
3.1/2							◆		◆		◆		◆	■	◆	■	
3.3/4									◆								
4							◆		◆		◆		◆	■	◆	■	
4.1/2							◆		◆		◆				◆	■	
5							◆		◆		◆		◆		◆	■	
5.1/2															◆	■	
6							◆		◆		◆				◆	■	
7									◆		◆				◆		
8									◆		◆				◆		
9											■				■		
10															■		
11															■		
12															■		

CLICK HERE TO RETURN TO THE CONTENTS PAGE



+ 37 064 411 786



Inquiry@invayear.com



www.invayear.com

HEXAGON HEAD SET SCREWS ANSI B18.2.1

Material grades: A2: ■ A4: ◆

k (Max)	0.371	0.403	0.403	0.483	0.483	0.563	0.563	0.627	0.627									
s (Max)	0.812	0.938	0.938	1.125	1.125	1.312	1.312	1.500	1.500									
Length/dim	9/16-18	5/8-11	5/8-18	3/4-10	3/4-16	7/8-9	7/8-14	1-8	1-12									
3		■◆		■◆		■◆		■◆	■◆									
3.1/4								■◆	■◆									
3.1/2		■◆		■◆		■◆		■◆	■◆									
3.3/4																		
4		■◆		■◆		■◆		■◆	■◆									
4.1/2		■◆		■◆		■◆		■◆	■◆									
5		■◆		■◆		■◆		■◆	■◆									
5.1/2				■◆		■◆		■◆	■◆									
6		■◆		■◆		■◆		■◆	■◆									
7		■◆		■◆		■		■	■									
8		■◆		■◆		■		■	■									
9		■		■		■		■	■									
10		■		■		■		■	■									
11		■		■		■		■	■									
12		■		■		■		■	■									

CLICK HERE TO RETURN TO THE CONTENTS PAGE



+ 37 064 411 786



Inquiry@invayear.com



www.invayear.com

HEXAGON HEAD BOLTS ANSI B18.2.1

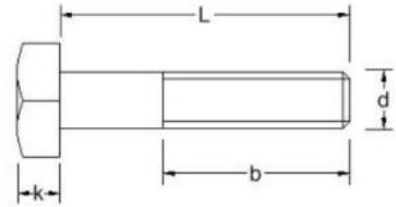

Material grades: A2: ■ A4: ◆

k (Max)	0.163	0.163	0.211	0.211	0.243	0.243	0.291	0.291	0.323	0.323	0.371	0.371	0.403	0.403	0.483	0.483	0.563
s (Max)	0.438	0.438	0.500	0.500	0.562	0.562	0.625	0.625	0.750	0.750	0.812	0.812	0.938	0.938	1.125	1.125	1.312
Length/dim	1/4-20	1/4-28	5/16-18	5/16-24	3/8-16	3/8-24	7/16-14	7/16-20	1/2-13	1/2-20	9/16-12	9/16-18	5/8-11	5/8-18	3/4-10	3/4-16	7/8-9
1.1/4	◆	◆															
1.3/8	◆	◆															
1.1/2	◆	◆	◆	◆	◆	◆											
1.5/8	◆	◆															
1.3/4	◆	◆	◆	◆	◆	◆	◆	◆	◆	◆							
2	◆	◆	◆	◆	◆	◆	◆	◆	◆	◆	◆	■		◆			
2.1/4	◆	◆	◆	◆	◆	◆	◆	◆	◆	◆	◆	■	◆	◆			
2.1/2	◆	◆	◆	◆	◆	◆	◆	◆	◆	◆	◆	■	◆	◆	◆	■	◆
2.3/4	◆	◆	◆	◆	◆	◆	◆	◆	◆	◆	◆	■	◆	◆	◆	■	◆
3	◆	◆	◆	◆	◆	◆	◆	◆	◆	◆	◆	■	◆	◆	◆	■	◆
3.1/4	◆	◆	◆	◆	◆		◆	◆	◆	◆			◆		◆	■	◆
3.1/2	◆	◆	◆	◆	◆	◆	◆	◆	◆	◆	◆	■	◆	◆	◆	■	◆
3.3/4	◆	◆	◆		◆	◆			◆	◆			◆	◆	◆	■	
4	◆	◆	◆	◆	◆	◆	◆	◆	◆	◆	◆	■	◆	◆	◆	■	◆
4.1/4															◆		
4.1/2	◆	◆	◆	■	◆	■	◆	◆	◆	◆	■		◆	■	◆	■	◆
5	◆	■	◆	■	◆	■	◆		◆	◆	■		◆	■	◆	■	◆
5.1/2	◆	■	◆	■	◆	■	◆		◆	■			◆	■	◆	■	◆

CLICK HERE TO RETURN TO THE CONTENTS PAGE



+ 37 064 411 786



Inquiry@invayear.com

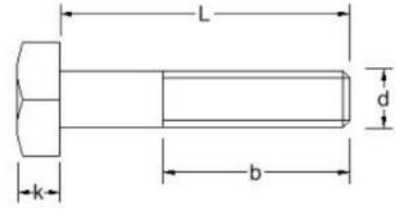

www.invayear.com

HEXAGON HEAD BOLTS ANSI B18.2.1

Material grades: A2: ■ A4: ◆

k (Max)	0.563	0.627																
s (Max)	1.312	1.500																
Length/dim	7/8-14	1-8																
1.1/4																		
1.3/8																		
1.1/2																		
1.5/8																		
1.3/4																		
2																		
2.1/4																		
2.1/2	■	◆																
2.3/4	■	◆																
3	■	◆																
3.1/4	■	◆																
3.1/2	■	◆																
3.3/4	■	◆																
4	■	◆																
4.1/4																		
4.1/2	■	◆																
5	■	◆																
5.1/2	■	◆																

CLICK HERE TO RETURN TO THE CONTENTS PAGE



+ 37 064 411 786



Inquiry@invayear.com



www.invayear.com

HEXAGON HEAD BOLTS ANSI B18.2.1

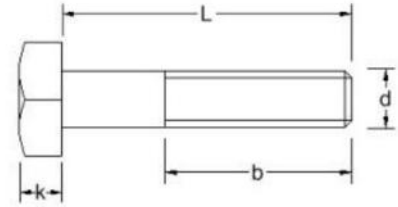

Material grades: A2: ■ A4: ◆

k (Max)	0.163	0.163	0.211	0.211	0.243	0.243	0.291	0.291	0.323	0.323	0.371	0.371	0.403	0.403	0.483	0.483	0.563
s (Max)	0.438	0.438	0.500	0.500	0.562	0.562	0.625	0.625	0.750	0.750	0.812	0.812	0.938	0.938	1.125	1.125	1.312
Length/dim	1/4-20	1/4-28	5/16-18	5/16-24	3/8-16	3/8-24	7/16-14	7/16-20	1/2-13	1/2-20	9/16-12	9/16-18	5/8-11	5/8-18	3/4-10	3/4-16	7/8-9
6	■◆	■	■◆	■	■◆	■	■◆		■◆	■			■◆	■	■◆	■	■◆
6.1/2					■◆				◆				■◆		■◆		
7	■◆		■◆		■◆				■◆				■◆		■◆		■◆
7.1/2					■◆				■◆								
8	■◆		■◆		■◆				■◆				■◆		■◆		■◆
8.1/2					■◆				■◆								
9	■◆		■◆		■◆				■◆				■◆		■◆		■◆
10	■◆		■◆		■◆				■◆				■◆		■◆		■◆
11	■		■		■				■◆				■◆		■◆		■◆
12	■		■		■				■◆				■◆		■◆		■◆
14					■				■◆				■◆		■◆		■◆
16					■				■				■◆		■◆		■
18									■				■		■◆		■
20									■				■		■		■

CLICK HERE TO RETURN TO THE CONTENTS PAGE



+ 37 064 411 786



Inquiry@invayear.com

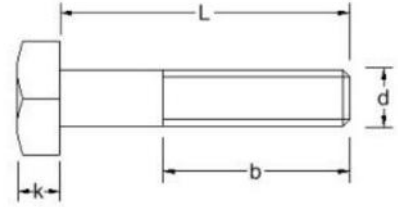

www.invayear.com

HEXAGON HEAD BOLTS ANSI B18.2.1

Material grades: A2: ■ A4: ◆

k (Max)	0.563	0.627																
s (Max)	1.312	1.500																
Length/dim	7/8-14	1-8																
6	■	◆◆																
6.1/2		◆◆																
7		◆◆																
7.1/2																		
8		◆◆																
8.1/2																		
9		◆◆																
10		◆◆																
11		◆◆																
12		◆◆																
14		◆◆																
16		■																
18		■																
20																		

[CLICK HERE TO RETURN TO THE CONTENTS PAGE](#)



+ 37 064 411 786



Inquiry@invayear.com

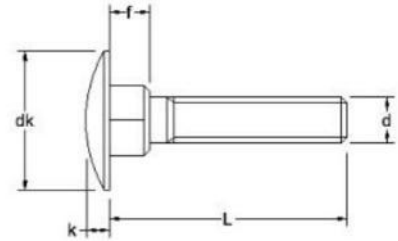
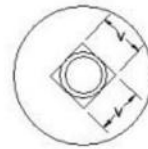

www.invayear.com

 Material grades: **A2**

Material grades: A2	0.594	0.719	0.844	1.094	1.344	1.594											
dk (Max)	0.594	0.719	0.844	1.094	1.344	1.594											
f (Max)	0.156	0.187	0.219	0.281	0.344	0.406											
k (Max)	0.145	0.176	0.208	0.270	0.344	0.406											
v (Max)	0.260	0.324	0.388	0.515	0.642	0.768											
Length/dim	1/4-20	5/16-18	3/8-16	1/2-13	5/8-11	3/4-10											
1	■	■															
1.1/4	■	■															
1.1/2	■	■	■	■	■												
2	■	■	■	■	■	■											
2.1/4		■															
2.1/2	■	■	■	■	■	■											
2.3/4		■															
3	■	■	■	■	■	■											
3.1/2	■	■	■	■	■	■											
4	■	■	■	■	■	■											

CLICK HERE TO RETURN TO THE CONTENTS PAGE



+ 37 064 411 786



Inquiry@invayear.com

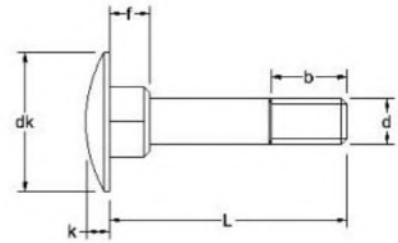
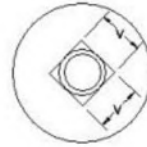

www.invayear.com

CARRIAGE BOLTS ANSI B18.5

Material grades: A2:■

dk (Max)	0.594	0.719	0.844	1.094	1.344	1.594												
f (Max)	0.156	0.187	0.219	0.281	0.344	0.406												
k (Max)	0.145	0.176	0.208	0.270	0.344	0.406												
v (Max)	0.260	0.324	0.388	0.515	0.642	0.768												
Length/dim	1/4-20	5/16-18	3/8-16	1/2-13	5/8-11	3/4-10												
4.1/2	■	■	■	■	■	■												
5	■	■	■	■	■	■												
5.1/2	■	■	■	■	■													
6	■	■	■	■	■	■												
6.1/2	■	■	■	■	■													
7	■	■	■	■	■	■												
7.1/2		■	■	■	■													
8	■	■	■	■	■	■												
8.1/2		■	■	■	■													
9	■	■	■	■	■	■												
9.1/2		■	■	■														
10	■	■	■	■	■	■												
11		■	■	■														
12		■	■	■	■	■												
14		■	■	■	■	■												
16			■	■	■	■												
18			■	■	■	■												

CLICK HERE TO RETURN TO THE CONTENTS PAGE



+ 37 064 411 786



Inquiry@invayear.com

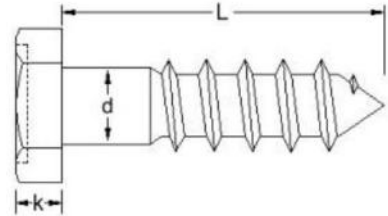

www.invayear.com

HEXAGON HEAD COACH SCREWS ANSI B18.2.1

 Material grades: **A2**

d (Max)	0.260	0.324	0.388	0.515	0.642	0.768												
k (Max)	0.188	0.235	0.268	0.364	0.444	0.524												
s (Max)	0.375	0.500	0.562	0.750	0.938	1.125												
TPI	10	9	7	6	5	4.1/2												
Length/dim	1/4	5/16	3/8	1/2	5/8	3/4												
2	■	■	■	■	■	■												
2.1/2	■	■	■	■	■	■												
3	■	■	■	■	■	■												
3.1/2	■	■	■	■	■	■												
4	■	■	■	■	■	■												
5	■	■	■	■	■	■												
6	■	■	■	■	■	■												
6.1/2	■	■	■	■	■	■												
7	■	■	■	■	■	■												
7.1/2			■	■	■													
8	■	■	■	■	■	■												
8.1/2			■	■	■	■												
9			■	■	■	■												
10	■	■	■	■	■	■												
11				■														
12			■	■	■	■												
14			■	■	■	■												
16				■														

CLICK HERE TO RETURN TO THE CONTENTS PAGE



+ 37 064 411 786



Inquiry@invayear.com

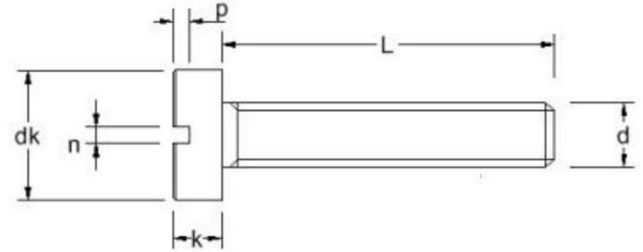

www.invayear.com

SLOT CHEESE MACHINE SCREWS DIN 84

Material grades: A2: ■ A4: ◆

dk	2.0	2.3	2.6	3.0	*	3.8	4.5	5.5	6.0	7.0	8.5	10	13	16			
k	0.7	0.8	0.9	1.0	*	1.3	1.6	2.0	2.4	2.6	3.3	3.9	5	6			
n	0.25	0.30	0.30	0.40	*	0.50	0.60	0.80	1.0	1.2	1.2	1.6	2.0	2.5			
Pitch	0.25	0.25	0.30	0.35	*	0.4	0.45	0.5	0.6	0.7	0.8	1.0	1.25	1.5			
p	0.25	0.30	0.40	0.45	*	0.60	0.70	0.85	1.0	1.1	1.3	1.6	2.0	2.4			
Length/dim	M1.0	M1.2	M1.4	M1.6	M1.7	M2	M2.5	M3	M3.5	M4	M5	M6	M8	M10			
2	■	■	■	■		◆											
2.4		■															
3	■	■	■	◆	■	◆	◆	◆									
4	■	■	■	◆	■	◆	◆	◆		◆							
5	■	■	■	◆	■	◆	◆	◆	◆	◆	◆						
6	■	■	■	◆		◆	◆	◆	◆	◆	◆	◆	◆				
8	■	■	■	◆		◆	◆	◆	◆	◆	◆	◆	◆				
10	■	■	■	◆	■	◆	◆	◆	◆	◆	◆	◆	◆	◆			
12	■	■	■	◆		◆	◆	◆	◆	◆	◆	◆	◆	◆			
14				◆		◆	◆	◆		◆	◆	◆	◆	◆			
16				◆		◆	◆	◆	◆	◆	◆	◆	◆	◆	◆		
18				■		◆	◆	◆		◆	◆	◆	◆	◆	◆	■	
20				■		◆	◆	◆	◆	◆	◆	◆	◆	◆	◆	◆	
22						◆	◆	◆		◆	■	◆	◆	◆	◆		
25						◆	◆	◆	◆	◆	◆	◆	◆	◆	◆	◆	

CLICK HERE TO RETURN TO THE CONTENTS PAGE



+ 37 064 411 786



Inquiry@invayear.com



www.invayear.com

SLOT CHEESE MACHINE SCREWS DIN 84

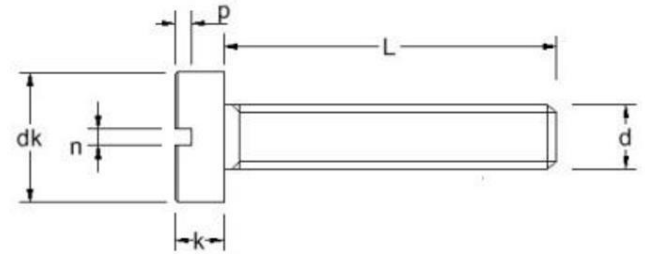

Material grades: A2: ■ A4: ◆

dk	2.0	2.3	2.6	3.0	*	3.8	4.5	5.5	6.0	7.0	8.5	10	13	16			
k	0.7	0.8	0.9	1.0	*	1.3	1.6	2.0	2.4	2.6	3.3	3.9	5	6			
n	0.25	0.30	0.30	0.40	*	0.50	0.60	0.80	1.0	1.2	1.2	1.6	2.0	2.5			
Pitch	0.25	0.25	0.30	0.35	*	0.4	0.45	0.5	0.6	0.7	0.8	1.0	1.25	1.5			
p	0.25	0.30	0.40	0.45	*	0.60	0.70	0.85	1.0	1.1	1.3	1.6	2.0	2.4			
Length/dim	M1.0	M1.2	M1.4	M1.6	M1.7	M2	M2.5	M3	M3.5	M4	M5	M6	M8	M10			
28							■				◆	◆					
30						◆	◆	◆	◆	◆	◆	◆	◆	◆			
35						■	◆	◆	◆	◆	◆	◆	◆	◆			
40						■	◆	◆	◆	◆	◆	◆	◆	◆			
45								◆		◆	◆	◆	◆	◆			
50								◆		◆	◆	◆	◆	◆			
55								◆		◆	◆	◆	◆				
60								◆		◆	◆	◆	◆	◆			
65										◆	◆	■					
70										◆	◆	◆	◆	◆			
75												◆					
80										◆	◆	◆	◆	◆			
85												■					
90										◆	◆	◆	◆	◆			
100										◆	◆	◆	◆	◆			

[CLICK HERE TO RETURN TO THE CONTENTS PAGE](#)



+ 37 064 411 786



Inquiry@invayear.com

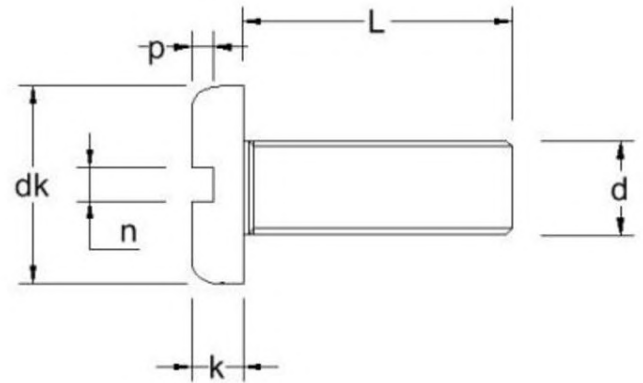

www.invayear.com

SLOT PAN MACHINE SCREWS DIN 85

Material grades: A2: ■ A4: ◆

dk (Max)	4.0	5.0	6.0	7.0	8.0	10	12	16	20									
k (Max)	1.3	1.5	1.8	2.0	2.4	3.0	3.6	4.8	6									
n	0.50	0.60	0.80	1.0	1.2	1.2	1.6	2.0	2.81									
Pitch	0.4	0.45	0.5	0.6	0.7	0.8	1.0	1.25	1.5									
p	0.40	0.50	0.70	1.0	1.0	1.2	1.4	1.9	2.4									
Length/dim	M2	M2.5	M3	M3.5	M4	M5	M6	M8	M10									
3	■◆	■◆	■◆															
4	■◆	■◆	■◆															
5	■◆	■◆	■◆	■◆	■◆													
6	■◆	■◆	■◆	■◆	■◆	■◆	■◆											
8	■◆	■◆	■◆	■◆	■◆	■◆	■◆	■◆	■◆									
10	■◆	■◆	■◆	■◆	■◆	■◆	■◆	■◆	■◆									
12	■◆	■◆	■◆	■◆	■◆	■◆	■◆	■◆	■◆									
14	■◆	■◆	■◆	■◆	■◆	■◆	■◆											
16	■◆	■◆	■◆	■◆	■◆	■◆	■◆	■◆	■◆	■◆								
18	■◆	■◆	■◆	■◆	■◆	■◆	■◆	■◆	■◆									
20	■◆	■◆	■◆	■◆	■◆	■◆	■◆	■◆	■◆	■◆								
22			■◆	■◆	■◆	■◆	■◆											
25	■◆	■◆	■◆	■◆	■◆	■◆	■◆	■◆	■◆	■◆								
30	■◆	■◆	■◆	■◆	■◆	■◆	■◆	■◆	■◆	■◆								
35			■◆	■◆	■◆	■◆	■◆	■◆	■◆	■◆								

CLICK HERE TO RETURN TO THE CONTENTS PAGE



+ 37 064 411 786



Inquiry@invayear.com

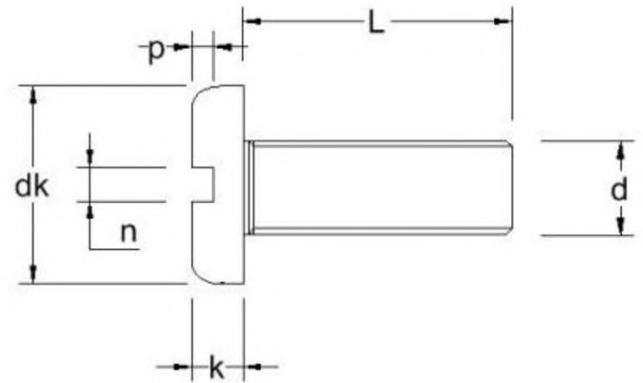

www.invayear.com

SLOT PAN MACHINE SCREWS DIN 85

Material grades: A2: ■ A4: ◆

dk (Max)	4.0	5.0	6.0	7.0	8.0	10	12	16	20										
k (Max)	1.3	1.5	1.8	2.0	2.4	3.0	3.6	4.8	6										
n	0.50	0.60	0.80	1.0	1.2	1.2	1.6	2.0	2.81										
Pitch	0.4	0.45	0.5	0.6	0.7	0.8	1.0	1.25	1.5										
p	0.40	0.50	0.70	1.0	1.0	1.2	1.4	1.9	2.4										
Length/dim	M2	M2.5	M3	M3.5	M4	M5	M6	M8	M10										
40			■ ◆	■ ◆	■ ◆	■ ◆	■ ◆	■ ◆	■ ◆										
45			■ ◆	■ ◆	■ ◆	■ ◆	■ ◆	■ ◆	■ ◆										
50			■ ◆	■ ◆	■ ◆	■ ◆	■ ◆	■ ◆	■ ◆										
55					■ ◆	■ ◆	■ ◆	■ ◆	■ ◆										
60					■ ◆	■ ◆	■ ◆	■ ◆	■ ◆										
65						■ ◆	■ ◆	■ ◆	■ ◆										
70						■ ◆	■ ◆	■ ◆	■ ◆										
75						■ ◆	■ ◆	■ ◆	■ ◆										
80						■ ◆	■ ◆	■ ◆	■ ◆										
90						■ ◆	■ ◆	■ ◆	■ ◆										
100						■ ◆	■ ◆	■ ◆	■ ◆										

[CLICK HERE TO RETURN TO THE CONTENTS PAGE](#)



+ 37 064 411 786



Inquiry@invayear.com

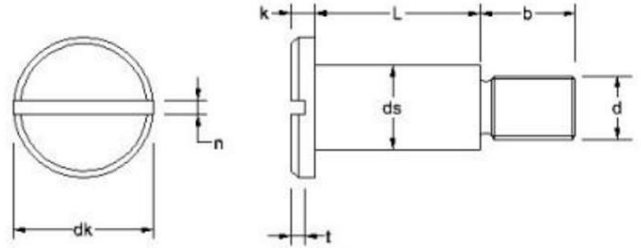

www.invayear.com

SLOT PAN SHOULDER SCREWS DIN 923

Material grades: A2: ■

b	4.5	6.0	7.0	9.0	11.0														
dk	7.0	8.5	11.0	13.0	16.0														
ds	4.0	5.5	7.0	8.0	10.0														
k	1.8	2.4	2.7	3.1	3.8														
n	0.8	1.0	1.2	1.6	2.0														
Pitch	0.5	0.7	0.8	1.0	1.25														
t (Min)	0.9	1.2	1.3	1.5	1.9														
Length/dim	M3	M4	M5	M6	M8														
2	■	■																	
2.5	■	■	■																
3	■	■	■	■															
4	■	■	■	■															
5	■	■	■	■	■														
6	■	■	■	■	■														
8	■	■	■	■	■														
10	■	■	■	■	■														
12	■	■	■	■	■														
16	■	■	■	■	■														
20			■	■	■														
25				■															

[CLICK HERE TO RETURN TO THE CONTENTS PAGE](#)

+ 37 064 411 786

Inquiry@invayear.com

www.invayear.com

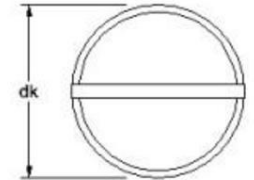
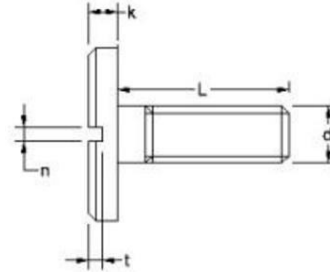
 Material grades: **A2**

dk	6	8	12	16	20	25													
k	1.2	1.8	2.4	2.7	3.1	3.8													
n	0.63	0.9	1.1	1.4	1.6	2.0													
Pitch	0.4	0.5	0.7	0.8	1.0	1.25													
t (Min)	0.6	0.9	1.2	1.3	1.5	1.9													
Length/dim	M2	M3	M4	M5	M6	M8													
2.5	■																		
3	■																		
4	■	■																	
5	■	■	■																
6		■	■	■															
8		■	■	■															
10		■	■	■	■														
12		■	■	■	■														
16			■	■	■														
20			■	■	■	■													
25				■	■	■	■												
30					■	■													

[CLICK HERE TO RETURN TO THE CONTENTS PAGE](#)



+ 37 064 411 786



Inquiry@invayear.com

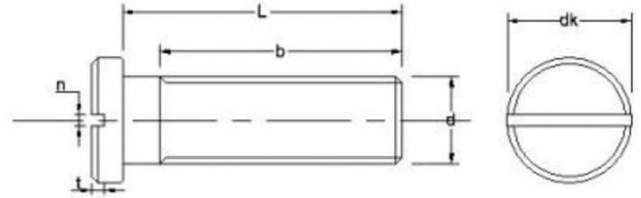

www.invayear.com

REDUCED HEAD SLOT PAN MACHINE SCREWS DIN 920

Material grades: A2: ■

b (Min)	6	9	12	15	18													
dk	2.8	4.0	5.5	6.5	8													
k	1.2	1.8	2.4	2.7	3.1													
n	0.30	0.50	0.6	0.8	1.0													
Pitch	0.4	0.5	0.7	0.8	1.0													
t	0.60	0.90	1.2	1.3	1.5													
Length/dim	M2	M2.5	M3	M4	M5	M6												
4	■	■	■	■														
5	■	■	■	■	■													
6	■	■	■	■	■	■												
8	■	■	■	■	■	■												
10	■	■	■	■	■	■												
12		■	■	■	■	■												
16		■	■	■	■	■												
20					■	■												
25						■												

[CLICK HERE TO RETURN TO THE CONTENTS PAGE](#)

+ 37 064 411 786

Inquiry@invayear.com

www.invayear.com

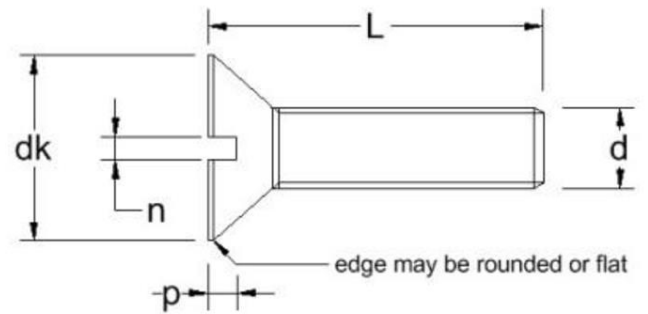
SLOT COUNTERSUNK MACHINE SCREWS DIN 963

Material grades: A2: ■ A4: ◆

dk	1.9	2.3	2.6	3.0	3.8	4.7	5.6	6.5	7.5	9.2	11	14.5	18				
k	0.7	0.8	0.9	1.0	1.3	1.5	1.9	1.90	2.2	2.5	3.0	4.0	5.0				
n	0.25	0.30	0.30	0.40	0.50	0.60	0.80	0.8	1.0	1.2	1.6	2.0	2.5				
Pitch	0.25	0.25	0.30	0.35	0.4	0.45	0.5	0.6	0.7	0.8	1.0	1.25	1.5				
p	0.30	0.35	0.40	0.45	0.60	0.70	0.85	1.0	1.1	1.3	1.6	2.1	2.6				
Length/dim	M1.0	M1.2	M1.4	M1.6	M2	M2.5	M3	M3.5	M4	M5	M6	M8	M10	M12			
2	■	■	■	■													
3	■	■	■	◆	◆												
4	■	■	■	◆	◆	◆	◆										
5	■	■	■	◆	◆	◆	◆	■	◆								
6	■	■	■	◆	◆	◆	◆	◆	◆	◆							
8	■	■	■	◆	◆	◆	◆	◆	◆	◆	◆						
10	■	■	■	◆	◆	◆	◆	◆	◆	◆	◆	◆	◆				
12		■	■	■	◆	◆	◆	◆	◆	◆	◆	◆	◆				
14				■	◆	◆	◆	◆	◆	◆	◆	◆	◆				
16				■	◆	◆	◆	◆	◆	◆	◆	◆	◆	◆			
18					◆	◆	◆	◆	◆	◆	◆	◆	◆				
20				■	◆	◆	◆	◆	◆	◆	◆	◆	◆	◆	◆		
22					◆	◆	◆	◆		■	◆	◆	◆	■			
25					◆	◆	◆	◆	◆	◆	◆	◆	◆	◆	◆		
28					◆												

CLICK HERE TO RETURN TO THE CONTENTS PAGE



+ 37 064 411 786



Inquiry@invayear.com

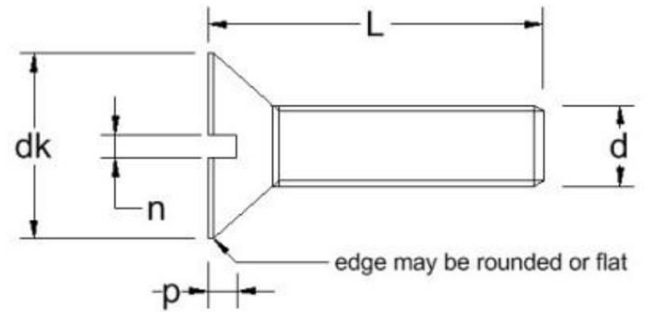

www.invayear.com

SLOT COUNTERSUNK MACHINE SCREWS DIN 963

Material grades: A2: ■ A4: ◆

Length/dim	M1.0	M1.2	M1.4	M1.6	M2	M2.5	M3	M3.5	M4	M5	M6	M8	M10	M12			
30					■◆	■	■◆	■◆	■◆	■◆	■◆	■◆	■◆	■◆			
35					■◆		■◆	■◆	■◆	■◆	■◆	■◆	■◆	■◆			
40					■◆		■◆	■	■◆	■◆	■◆	■◆	■◆	■◆			
45							■◆		■◆	■◆	■◆	■◆	■◆	■◆			
50							■◆		■◆	■◆	■◆	■◆	■◆	■◆			
55							■◆		■◆	■◆	■◆	■◆	■◆	■◆			
60							■◆		■◆	■◆	■◆	■◆	■◆	■◆			
65									■◆	■◆	■◆	■◆	■◆	■◆			
70									■◆	■◆	■◆	■◆	■◆	■◆			
75										■◆	■◆	■◆	■◆	■◆			
80									■◆	■◆	■◆	■◆	■◆	■◆			
90										■◆	■◆	■◆	■◆	■◆			
100										■◆	■◆	■◆	■◆	■◆			
110											■	■◆	■◆	■◆			
120											■	■◆	■◆				

CLICK HERE TO RETURN TO THE CONTENTS PAGE



+ 37 064 411 786



Inquiry@invayear.com



www.invayear.com

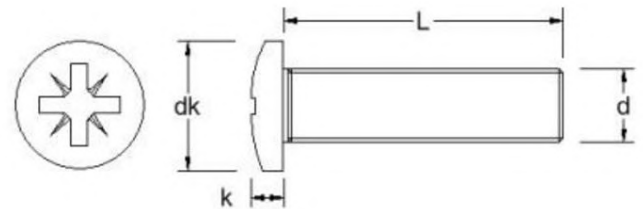

Material grades: A2: ■ A4: ◆

Drive	#0	#0	#1	#1	#2	#2	#2	#3	#4							
dk (Max)	3.2	4	5	6	7	8	10	12	16							
k (Max)	1.42	1.72	2.12	2.52	2.82	3.25	3.95	4.75	6.15							
Pitch	0.35	0.4	0.45	0.5	0.6	0.7	0.8	1.0	1.25							
Length/dim	M1.6	M2	M2.5	M3	M3.5	M4	M5	M6	M8							
2	■◆															
3	■◆	■◆	■◆	■◆												
4	■◆	■◆	■◆	■◆		■◆										
5	■◆	■◆	■◆	■◆	■	■◆										
6	■◆	■◆	■◆	■◆	■	■◆	■◆									
8	■◆	■◆	■◆	■◆	■	■◆	■◆	■◆								
10	■◆	■◆	■◆	■◆	■	■◆	■◆	■◆	■◆							
12	■◆	■◆	■◆	■◆	■	■◆	■◆	■◆	■◆	■◆						
14	■◆	■◆	■◆	■◆		■◆	■◆	■◆	■◆	■						
16	■◆	■◆	■◆	■◆	■	■◆	■◆	■◆	■◆	■◆						
18	■◆	■◆	■◆	■◆			■◆	■◆								
20	■◆	■◆	■◆	■◆	■	■◆	■◆	■◆	■◆	■◆						
22			■◆	■◆		■	■◆	■◆	■◆	■						
25		■	■◆	■◆	■	■◆	■◆	■◆	■◆	■◆						
28			■◆	■◆		■◆	■	■◆								
30		■	■◆	■◆	■	■◆	■◆	■◆	■◆	■◆						

CLICK HERE TO RETURN TO THE CONTENTS PAGE



+ 37 064 411 786



Inquiry@invayear.com

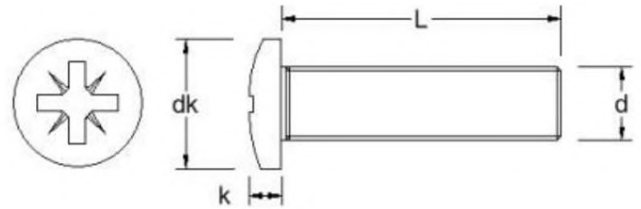

www.invayear.com

POZI PAN MACHINE SCREWS DIN 7985 Z

Material grades: A2: ■ A4: ◆

Drive	#0	#0	#1	#1	#2	#2	#2	#3	#4								
dk (Max)	3.2	4	5	6	7	8	10	12	16								
k (Max)	1.42	1.72	2.12	2.52	2.82	3.25	3.95	4.75	6.15								
Pitch	0.35	0.4	0.45	0.5	0.6	0.7	0.8	1.0	1.25								
Length/dim	M1.6	M2	M2.5	M3	M3.5	M4	M5	M6	M8								
35				■ ◆		■ ◆	■ ◆	■ ◆	■ ◆								
40				■ ◆		■ ◆	■ ◆	■ ◆	■ ◆								
45				■ ◆		■ ◆	■ ◆	■ ◆	■ ◆								
50				■ ◆		■ ◆	■ ◆	■ ◆	■ ◆								
55				■ ◆		■ ◆	■ ◆	■ ◆	■ ◆								
60				■ ◆		■ ◆	■ ◆	■ ◆	■ ◆								
65						■	■ ◆	■ ◆	■ ◆								
70						■ ◆	■ ◆	■ ◆	■ ◆								
75							■ ◆										
80						■ ◆	■ ◆	■ ◆	■ ◆								
90						■ ◆	■ ◆	■ ◆	■ ◆								
100						■ ◆	■ ◆	■ ◆	■ ◆								

[CLICK HERE TO RETURN TO THE CONTENTS PAGE](#)

+ 37 064 411 786

Inquiry@invayear.com

www.invayear.com

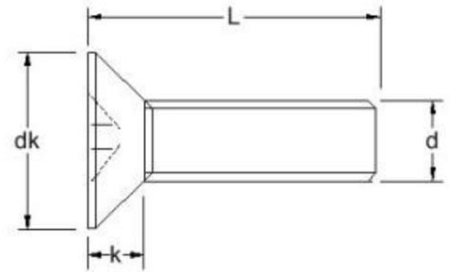
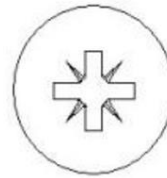

Material grades: A2: ■ A4: ◆

Drive	#0	#0	#1	#1	#2	#2	#2	#3	#4	#4						
dk	3.0	3.8	4.7	5.6	6.5	7.5	9.2	11	14.5	18						
k (Max)	0.96	1.2	1.5	1.65	1.9	2.2	2.5	3.0	4.0	5.0						
Pitch	0.35	0.4	0.45	0.5	0.6	0.7	0.8	1.0	1.25	1.5						
Length/dim	M1.6	M2	M2.5	M3	M3.5	M4	M5	M6	M8	M10						
2	■◆															
3	■◆	■◆	■													
4	■◆	■◆	■◆	■◆												
5	■◆	■◆	■◆	■◆		■◆										
6	■◆	■◆	■◆	■◆	■	■◆	■◆									
8	■◆	■◆	■◆	■◆	■	■◆	■◆	■◆	■◆							
10	■◆	■◆	■◆	■◆	■	■◆	■◆	■◆	■◆							
12	■◆	■◆	■◆	■◆	■	■◆	■◆	■◆	■◆	■◆						
14	■◆	■◆	■◆	■◆		■◆	■◆	■◆	■◆							
16	■◆	■◆	■◆	■◆	■	■◆	■◆	■◆	■◆	■◆						
18	■◆	■◆	■◆	■◆		■◆	■◆	■◆	■◆							
20	■◆	■◆	■◆	■◆	■	■◆	■◆	■◆	■◆	■◆	■◆					
22			■◆	■◆		■◆	■◆	■◆	■◆							
25		■◆	■◆	■◆	■	■◆	■◆	■◆	■◆	■◆	■◆					
28							■◆									
30		■◆	■◆	■◆	■	■◆	■◆	■◆	■◆	■◆	■◆					

[CLICK HERE TO RETURN TO THE CONTENTS PAGE](#)



+ 37 064 411 786



Inquiry@invayear.com

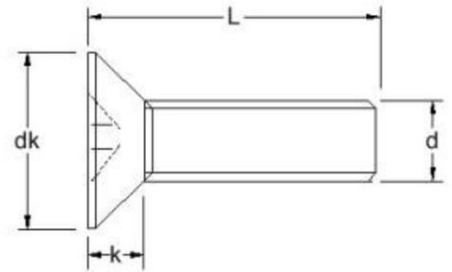
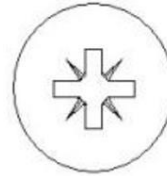

www.invayear.com

POZI COUNTERSUNK MACHINE SCREWS DIN 965 Z

Material grades: A2: ■ A4: ◆

Drive	#0	#0	#1	#1	#2	#2	#2	#3	#4	#4						
dk	3.0	3.8	4.7	5.6	6.5	7.5	9.2	11	14.5	18						
k (Max)	0.96	1.2	1.5	1.65	1.9	2.2	2.5	3.0	4.0	5.0						
Pitch	0.35	0.4	0.45	0.5	0.6	0.7	0.8	1.0	1.25	1.5						
Length/dim	M1.6	M2	M2.5	M3	M3.5	M4	M5	M6	M8	M10						
35				■ ◆		■ ◆	■ ◆	■ ◆	■ ◆	■ ◆						
40				■ ◆		■ ◆	■ ◆	■ ◆	■ ◆	■ ◆						
45				■ ◆		■ ◆	■ ◆	■ ◆	■ ◆	■ ◆						
50				■ ◆		■ ◆	■ ◆	■ ◆	■ ◆	■ ◆						
55				■ ◆		■ ◆	■ ◆	■ ◆								
60				■ ◆		■ ◆	■ ◆	■ ◆	■ ◆	■ ◆						
65						■ ◆	■ ◆	■ ◆								
70						■ ◆	■ ◆	■ ◆	■ ◆	■ ◆						
75						■ ◆		■ ◆								
80						■ ◆	■ ◆	■ ◆	■ ◆	■ ◆						
85						■ ◆										
90						■ ◆	■ ◆	■ ◆	■ ◆	■ ◆						
95						■ ◆										
100						■ ◆	■ ◆	■ ◆	■ ◆	■ ◆						
110								■ ◆								
120								■ ◆								

[CLICK HERE TO RETURN TO THE CONTENTS PAGE](#)

+ 37 064 411 786

Inquiry@invayear.com

www.invayear.com

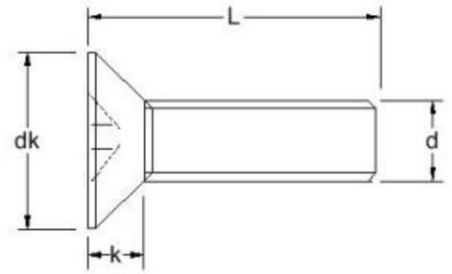
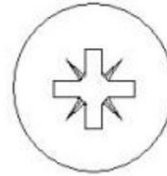
DIN 965 Z
POZI COUNTERSUNK MACHINE SCREWS DIN 965 Z

Material grades: A2: ■ A4: ◆

Drive	#0	#0	#1	#1	#2	#2	#2	#3	#4	#4								
dk	3.0	3.8	4.7	5.6	6.5	7.5	9.2	11	14.5	18								
k (Max)	0.96	1.2	1.5	1.65	1.9	2.2	2.5	3.0	4.0	5.0								
Pitch	0.35	0.4	0.45	0.5	0.6	0.7	0.8	1.0	1.25	1.5								
Length/dim	M1.6	M2	M2.5	M3	M3.5	M4	M5	M6	M8	M10								
130								■ ◆										
140								■ ◆										

[CLICK HERE TO RETURN TO THE CONTENTS PAGE](#)



+ 37 064 411 786



Inquiry@invayear.com

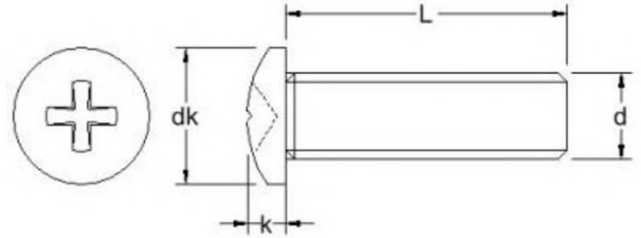

www.invayear.com

PHILLIPS PAN MACHINE SCREWS DIN 7985 H

Material grades: A2: ■ A4: ◆

Drive	#0	#0	#0	#1	#1	#2	#2	#3	#4							
dk (Max)	2.5	3.2	4	5	6	8	10	12	16							
k (Max)	0.8	1.42	1.72	2.12	2.52	3.25	3.95	4.75	6.15							
Pitch	0.3	0.35	0.4	0.45	0.5	0.7	0.8	1.0	1.25							
Length/dim	M1.4	M1.6	M2	M2.5	M3	M4	M5	M6	M8							
2	■ ◆															
3	■ ◆	■ ◆	■ ◆	■ ◆	■ ◆											
4	■ ◆	■ ◆	■ ◆	■ ◆	■ ◆	■ ◆										
5	■ ◆	■ ◆	■ ◆	■ ◆	■ ◆	■ ◆										
6	■ ◆	■ ◆	■ ◆	■ ◆	■ ◆	■ ◆	■ ◆									
8	■ ◆	■ ◆	■ ◆	■ ◆	■ ◆	■ ◆	■ ◆	■ ◆								
10	■ ◆	■ ◆	■ ◆	■ ◆	■ ◆	■ ◆	■ ◆	■ ◆	■ ◆							
12		■ ◆	■ ◆	■ ◆	■ ◆	■ ◆	■ ◆	■ ◆	■ ◆	■ ◆						
14		■ ◆	■ ◆	■ ◆	■ ◆	■ ◆	■ ◆	■ ◆	■ ◆	■ ◆						
16		■ ◆	■ ◆	■ ◆	■ ◆	■ ◆	■ ◆	■ ◆	■ ◆	■ ◆						
18		■ ◆	■ ◆	■ ◆	■ ◆	■ ◆	■ ◆	■ ◆	■ ◆	■ ◆						
20		■ ◆	■ ◆	■ ◆	■ ◆	■ ◆	■ ◆	■ ◆	■ ◆	■ ◆						
22				■ ◆	■ ◆	■ ◆	■ ◆	■ ◆	■ ◆	■ ◆						
25				■ ◆	■ ◆	■ ◆	■ ◆	■ ◆	■ ◆	■ ◆						
28					■ ◆	■ ◆	■ ◆	■ ◆	■ ◆	■ ◆						
30				■ ◆	■ ◆	■ ◆	■ ◆	■ ◆	■ ◆	■ ◆						

[CLICK HERE TO RETURN TO THE CONTENTS PAGE](#)



+ 37 064 411 786



Inquiry@invayear.com



www.invayear.com

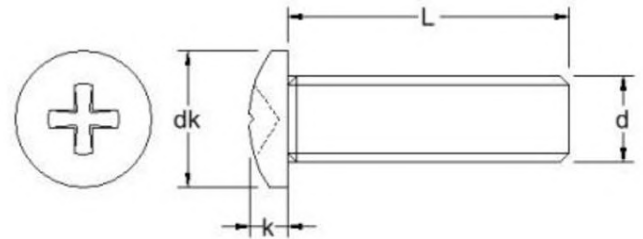

Material grades: A2: ■ A4: ◆

Drive	#0	#0	#0	#1	#1	#2	#2	#3	#4								
dk (Max)	2.5	3.2	4	5	6	8	10	12	16								
k (Max)	0.8	1.42	1.72	2.12	2.52	3.25	3.95	4.75	6.15								
Pitch	0.3	0.35	0.4	0.45	0.5	0.7	0.8	1.0	1.25								
Length/dim	M1.4	M1.6	M2	M2.5	M3	M4	M5	M6	M8								
35					■◆	■◆	■◆	■◆	■◆								
40					■◆	■◆	■◆	■◆	■◆								
45					■◆	■◆	■◆	■◆	■◆								
50					■◆	■◆	■◆	■◆	■◆								
55						■◆	■◆	■◆									
60					◆	■◆	■◆	■◆	■◆								
65						■◆	■◆	■◆	■◆								
70						■◆	■◆	■◆	■◆								
80						■◆	■◆	■◆	■◆								
90						■◆	■◆	■◆	■◆								
100						■◆	■◆	■◆	■◆								

CLICK HERE TO RETURN TO THE CONTENTS PAGE



+ 37 064 411 786



Inquiry@invayear.com

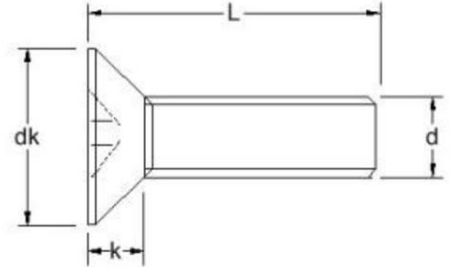
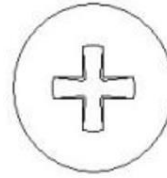

www.invayear.com

PHILLIPS COUNTERSUNK MACHINE SCREWS DIN 965 H

Material grades: A2: ■ A4: ◆

Drive	#0	#0	#0	#1	#1	#2	#2	#3	#4	#4								
dk	2.6	3.0	3.8	4.7	5.6	7.5	9.2	11	14.5	18								
k (Max)	0.9	0.96	1.2	1.5	1.65	2.2	2.5	3.0	4.0	5.0								
Pitch	0.30	0.35	0.4	0.45	0.5	0.7	0.8	1.0	1.25	1.5								
Length/dim	M1.4	M1.6	M2	M2.5	M3	M4	M5	M6	M8	M10								
2	■ ◆	■ ◆																
3	■ ◆	■ ◆	■ ◆															
4	■ ◆	■ ◆	■ ◆	■ ◆	■ ◆													
5	■ ◆	■ ◆	■ ◆	■ ◆	■ ◆	■ ◆												
6	■ ◆	■ ◆	■ ◆	■ ◆	■ ◆	■ ◆	■ ◆											
8	■ ◆	■ ◆	■ ◆	■ ◆	■ ◆	■ ◆	■ ◆	■ ◆										
10	■ ◆	■ ◆	■ ◆	■ ◆	■ ◆	■ ◆	■ ◆	■ ◆	■ ◆									
12		■ ◆	■ ◆	■ ◆	■ ◆	■ ◆	■ ◆	■ ◆	■ ◆									
14		■ ◆	■ ◆	■ ◆	■ ◆	■ ◆	■ ◆	■ ◆	■ ◆	■ ◆								
16		■ ◆	■ ◆	■ ◆	■ ◆	■ ◆	■ ◆	■ ◆	■ ◆	■ ◆	■ ◆							
18		■ ◆	■ ◆	■ ◆	■ ◆	■ ◆	■ ◆	■ ◆	■ ◆									
20		■ ◆	■ ◆	■ ◆	■ ◆	■ ◆	■ ◆	■ ◆	■ ◆	■ ◆								
22				■ ◆	■ ◆	■ ◆	■ ◆	■ ◆	■ ◆	■ ◆								
25				■ ◆	■ ◆	■ ◆	■ ◆	■ ◆	■ ◆	■ ◆	■ ◆							
30					■ ◆	■ ◆	■ ◆	■ ◆	■ ◆	■ ◆	■ ◆							
35					■ ◆	■ ◆	■ ◆	■ ◆	■ ◆	■ ◆	■ ◆							

[CLICK HERE TO RETURN TO THE CONTENTS PAGE](#)



+ 37 064 411 786



Inquiry@invayear.com



www.invayear.com

DIN 965 H

PHILLIPS COUNTERSUNK MACHINE SCREWS DIN 965 H

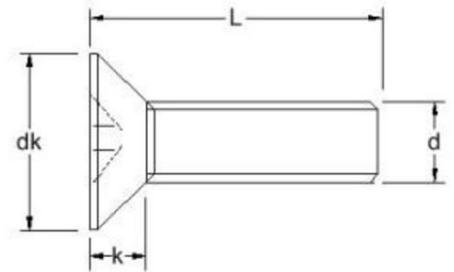
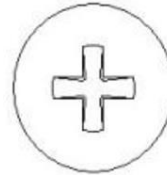

Material grades: A2: ■ A4: ◆

Drive	#0	#0	#0	#1	#1	#2	#2	#3	#4	#4							
dk	2.6	3.0	3.8	4.7	5.6	7.5	9.2	11	14.5	18							
k (Max)	0.9	0.96	1.2	1.5	1.65	2.2	2.5	3.0	4.0	5.0							
Pitch	0.30	0.35	0.4	0.45	0.5	0.7	0.8	1.0	1.25	1.5							
Length/dim	M1.4	M1.6	M2	M2.5	M3	M4	M5	M6	M8	M10							
40					◆	◆	◆	◆	◆	◆							
45					◆	◆	◆	◆	◆	◆							
50					◆	◆	◆	◆	◆	◆							
55							◆	◆									
60						◆	◆	◆	◆	◆							
65								◆									
70						◆	◆	◆	◆	◆							
75								◆	◆								
80						◆	◆	◆	◆	◆							
85							◆	◆									
90						◆	◆	◆	◆	◆							
95							◆										
100						◆	◆	◆	◆	◆							
110									◆								
120									◆								
130									◆								
150									◆								

[CLICK HERE TO RETURN TO THE CONTENTS PAGE](#)



+ 37 064 411 786



Inquiry@invayear.com

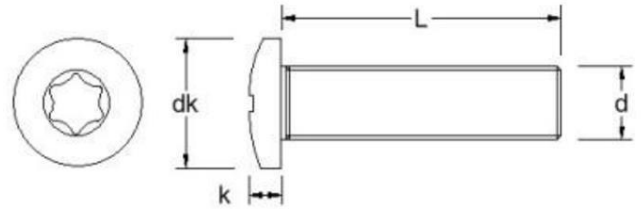

www.invayear.com

TX PAN MACHINE SCREWS DIN 7985 TX

Material grades: A2: ■ A4: ◆

dk (Max)	3.2	4	5	6	8	10	12	16									
k (Max)	1.42	1.72	2.12	2.52	3.25	3.95	4.75	6.15									
Pitch	0.35	0.4	0.45	0.5	0.7	0.8	1.0	1.25									
Length/dim	M1.6	M2	M2.5	M3	M4	M5	M6	M8									
2	■◆																
3	■◆	■◆	■◆	■◆													
4	■◆	■◆	■◆	■◆	■◆												
5	■◆	■◆	■◆	■◆	■◆												
6	■◆	■◆	■◆	■◆	■◆	■◆											
8	■◆	■◆	■◆	■◆	■◆	■◆	■◆										
10	■◆	■◆	■◆	■◆	■◆	■◆	■◆	■◆									
12	■◆	■◆	■◆	■◆	■◆	■◆	■◆	■◆	■◆								
14	■◆	■◆	■◆	■◆	■◆	■◆	■◆	■◆									
16	■◆	■◆	■◆	■◆	■◆	■◆	■◆	■◆	■◆								
18	■◆	■◆	■◆	■◆	■◆	■◆	■◆	■◆									
20	■◆	■◆	■◆	■◆	■◆	■◆	■◆	■◆	■◆								
22			■◆	■◆	■◆	■◆	■◆	■◆									
25			■◆	■◆	■◆	■◆	■◆	■◆	■◆								
28			■◆	■◆	■◆	■◆	■◆	■◆									
30			■◆	■◆	■◆	■◆	■◆	■◆	■◆								
35				■◆	■◆	■◆	■◆	■◆	■◆								

[CLICK HERE TO RETURN TO THE CONTENTS PAGE](#)



+ 37 064 411 786



Inquiry@invayear.com

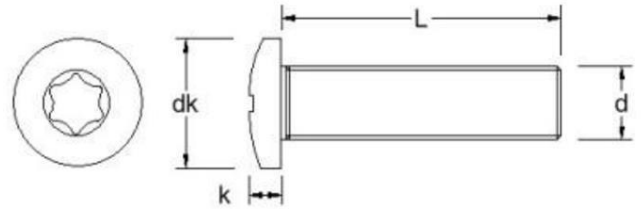

www.invayear.com

DIN 7985 TX
TX PAN MACHINE SCREWS DIN 7985 TX

Material grades: A2: ■ A4: ◆

dk (Max)	3.2	4	5	6	8	10	12	16									
k (Max)	1.42	1.72	2.12	2.52	3.25	3.95	4.75	6.15									
Pitch	0.35	0.4	0.45	0.5	0.7	0.8	1.0	1.25									
Length/dim	M1.6	M2	M2.5	M3	M4	M5	M6	M8									
40				■ ◆	■ ◆	■ ◆	■ ◆	■ ◆									
45				■ ◆	■ ◆	■ ◆	■ ◆	■ ◆									
50				■ ◆	■ ◆	■ ◆	■ ◆	■ ◆									
55				■ ◆	■ ◆	■ ◆	■ ◆										
60				■ ◆	■ ◆	■ ◆	■ ◆	■ ◆									
65					■ ◆	■ ◆	■ ◆										
70					■ ◆	■ ◆	■ ◆	■ ◆									
75					■ ◆	■ ◆	■										
80					■ ◆	■ ◆	■ ◆	■ ◆									
90					■ ◆	■ ◆	■ ◆										
100					■ ◆	■ ◆	■ ◆										

[CLICK HERE TO RETURN TO THE CONTENTS PAGE](#)

+ 37 064 411 786

Inquiry@invayear.com

www.invayear.com

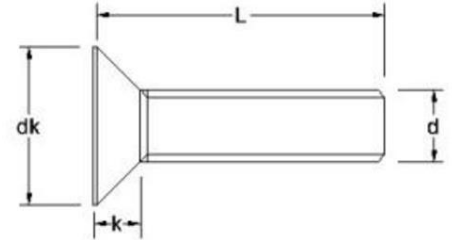
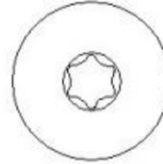
TX COUNTERSUNK MACHINE SCREWS DIN 965 TX

Material grades: A2: ■ A4: ◆

dk (Max)	3.2	3.8	4.7	5.6	7.5	9.2	11	14.5										
k	0.96	1.2	1.5	1.65	2.2	2.5	3.0	4.0										
Pitch	0.35	0.4	0.45	0.5	0.7	0.8	1.0	1.25										
Length/dim	M1.6	M2	M2.5	M3	M4	M5	M6	M8										
2	■◆																	
3	■◆	■◆	■◆															
4	■◆	■◆	■◆	■◆														
5	■◆	■◆	■◆	■◆	■◆													
6	■◆	■◆	■◆	■◆	■◆	■◆												
8	■◆	■◆	■◆	■◆	■◆	■◆	■◆											
10	■◆	■◆	■◆	■◆	■◆	■◆	■◆	■◆										
12	■◆	■◆	■◆	■◆	■◆	■◆	■◆	■◆	■◆									
14	■◆	■◆	■◆	■◆	■◆	■◆	■◆											
16	■◆	■◆	■◆	■◆	■◆	■◆	■◆	■◆										
18	■◆	■◆	■◆	■◆	■◆	■◆	■◆											
20	■◆	■◆	■◆	■◆	■◆	■◆	■◆	■◆	■◆									
22			■◆	■◆	■◆	■◆	■◆											
25			■◆	■◆	■◆	■◆	■◆	■◆										
28						■◆												
30				■◆	■◆	■◆	■◆	■◆										
35				■◆	■◆	■◆	■◆	■◆										

[CLICK HERE TO RETURN TO THE CONTENTS PAGE](#)



+ 37 064 411 786

Inquiry@invayear.com

www.invayear.com

DIN 965 TX

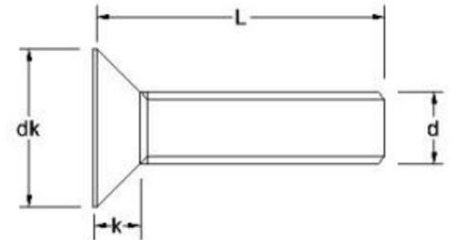
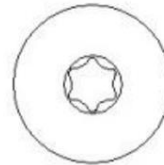
TX COUNTERSUNK MACHINE SCREWS DIN 965 TX



Material grades: A2: ■ A4: ◆

dk (Max)	3.2	3.8	4.7	5.6	7.5	9.2	11	14.5									
k	0.96	1.2	1.5	1.65	2.2	2.5	3.0	4.0									
Pitch	0.35	0.4	0.45	0.5	0.7	0.8	1.0	1.25									
Length/dim	M1.6	M2	M2.5	M3	M4	M5	M6	M8									
40				■◆	■◆	■◆	■◆	■◆									
45				■◆	■◆	■◆	■◆	■◆									
50				■◆	■◆	■◆	■◆	■◆									
55				■◆	■◆	■◆	■◆										
60				■◆	■◆	■◆	■◆	■◆									
65					■◆	■◆	■◆										
70					■◆	■◆	■◆	■◆									
75					■◆	■◆	■◆										
80					■◆	■◆	■◆	■◆									
85					■◆	■◆	■◆										
90					■◆	■◆	■◆										
95					■◆	■◆	■◆										
100					■◆	■◆	■◆										
110							■◆										
120							■◆										
130							■◆										
140							■◆										

[CLICK HERE TO RETURN TO THE CONTENTS PAGE](#)



+ 37 064 411 786



Inquiry@invayear.com

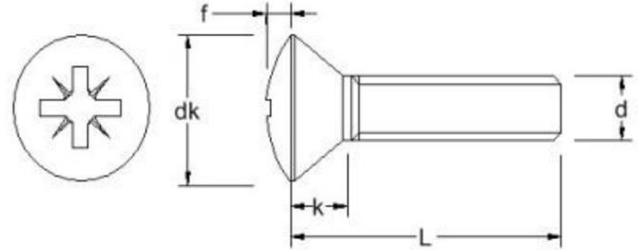

www.invayear.com

POZI RAISED COUNTERSUNK MACHINE SCREWS DIN 966 Z

Material grades: A2: ■ A4: ◆

Drive	#1	#1	#1	#2	#2	#3												
dk	3.8	4.7	5.6	7.5	9.2	11												
f	*	0.6	0.75	1.0	1.25	1.5												
k	1.2	1.5	1.65	2.2	2.5	3.0												
Pitch	0.40	0.45	0.5	0.7	0.8	1.0												
Length/dim	M2	M2.5	M3	M4	M5	M6												
3	■◆																	
4	■◆	■◆	■◆															
5	■◆	■◆	■◆	■◆														
6	■◆	■◆	■◆	■◆	■◆													
8	■◆	■◆	■◆	■◆	■◆	■◆												
10	■◆	■◆	■◆	■◆	■◆	■◆	■◆											
12	■◆	■◆	■◆	■◆	■◆	■◆	■◆											
14	■◆	■◆	■◆	■◆	■◆	■◆	■◆											
16	■◆	■◆	■◆	■◆	■◆	■◆	■◆											
18	■◆	■◆	■◆	■◆	■◆	■◆	■◆											
20	■◆	■◆	■◆	■◆	■◆	■◆	■◆											
22			■◆	■◆	■	■◆												
25	■◆	■◆	■◆	■◆	■◆	■◆	■◆											
28			■◆	■◆	■◆	■◆	■◆											
30	■◆	■◆	■◆	■◆	■◆	■◆	■◆											

[CLICK HERE TO RETURN TO THE CONTENTS PAGE](#)

+ 37 064 411 786

Inquiry@invayear.com

www.invayear.com

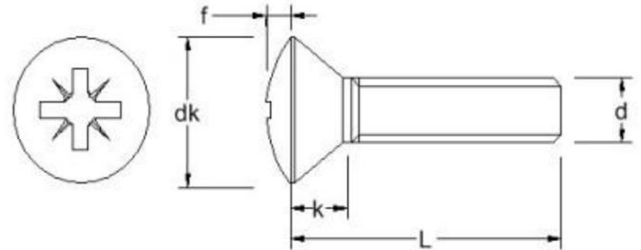

Material grades: A2: ■ A4: ◆

Drive	#1	#1	#1	#2	#2	#3											
dk	3.8	4.7	5.6	7.5	9.2	11											
f	*	0.6	0.75	1.0	1.25	1.5											
k	1.2	1.5	1.65	2.2	2.5	3.0											
Pitch	0.40	0.45	0.5	0.7	0.8	1.0											
Length/dim	M2	M2.5	M3	M4	M5	M6											
35			■ ◆	■ ◆	■ ◆	■ ◆											
40			■ ◆	■ ◆	■ ◆	■ ◆											
45			■ ◆	■ ◆	■ ◆	■ ◆											
50			■ ◆	■ ◆	■ ◆	■ ◆											
55				■ ◆	■ ◆	■ ◆											
60				■ ◆	■ ◆	■ ◆											
65				■ ◆	■ ◆	■ ◆											
70				■ ◆	■ ◆	■ ◆											
75				■ ◆	■ ◆	■ ◆											
80				■ ◆	■ ◆	■ ◆											
85					■ ◆	■ ◆											
90					◆	■ ◆											
95					■ ◆	■ ◆											
100					■ ◆	■ ◆											

[CLICK HERE TO RETURN TO THE CONTENTS PAGE](#)



+ 37 064 411 786



Inquiry@invayear.com

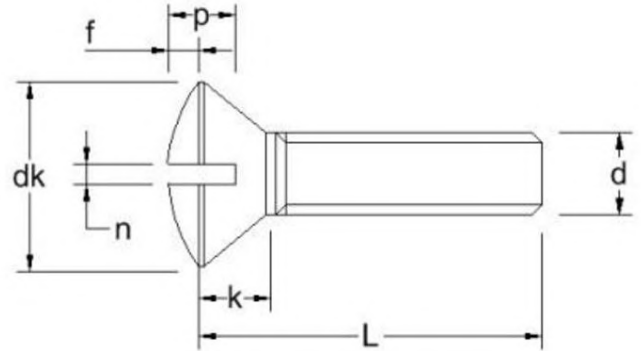

www.invayear.com

SLOT RAISED COUNTERSUNK MACHINE SCREWS DIN 964

Material grades: A2: ■ A4: ◆

dk	3.8	4.7	5.6	7.5	9.2	11	14.5	18									
f	0.5	0.6	0.75	1.0	1.25	1.5	2.0	*									
k (Max)	1.2	1.5	1.65	2.2	2.5	3.0	4.0	5.0									
n	0.5	0.6	0.8	1.0	1.2	1.6	2.0	2.5									
Pitch	0.4	0.45	0.5	0.7	0.8	1.0	1.25	1.5									
p (Min)	0.8	1.0	1.2	1.6	2.0	2.4	3.2	4.0									
Length/dim	M2	M2.5	M3	M4	M5	M6	M8	M10									
4	■◆																
5	■◆	■◆	■◆	■◆													
6	■◆	■◆	■◆	■◆	■◆												
8	■◆	■◆	■◆	■◆	■◆	■◆											
10	■◆	■◆	■◆	■◆	■◆	■◆	■◆	■									
12	■◆	■◆	■◆	■◆	■◆	■◆	■◆	■◆									
14	■		■◆	■◆	■◆												
16	■◆	■◆	■◆	■◆	■◆	■◆	■◆	■◆									
18	■		■◆	■◆	■◆			■◆									
20	■◆	■◆	■◆	■◆	■◆	■◆	■◆	■◆	■								
22			■◆	■◆	■◆	■◆											
25	■	■	■◆	■◆	■◆	■◆	■◆	■◆	■◆								
30		■	■◆	■◆	■◆	■◆	■◆	■◆	■◆								
35			■◆	■◆	■◆	■◆	■◆	■◆									

[CLICK HERE TO RETURN TO THE CONTENTS PAGE](#)

+ 37 064 411 786

Inquiry@invayear.com

www.invayear.com

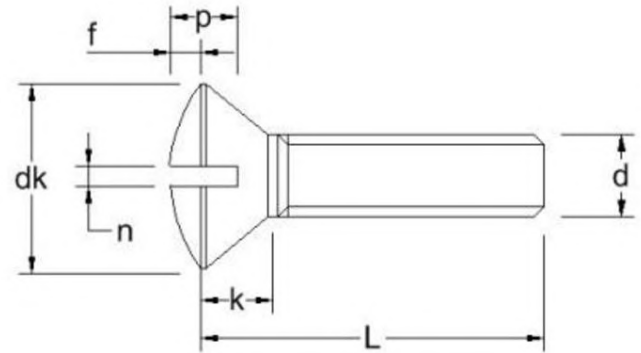

Material grades: A2: ■ A4: ◆

dk	3.8	4.7	5.6	7.5	9.2	11	14.5	18										
f	0.5	0.6	0.75	1.0	1.25	1.5	2.0	*										
k (Max)	1.2	1.5	1.65	2.2	2.5	3.0	4.0	5.0										
n	0.5	0.6	0.8	1.0	1.2	1.6	2.0	2.5										
Pitch	0.4	0.45	0.5	0.7	0.8	1.0	1.25	1.5										
p (Min)	0.8	1.0	1.2	1.6	2.0	2.4	3.2	4.0										
Length/dim	M2	M2.5	M3	M4	M5	M6	M8	M10										
40			■ ◆	■ ◆	■ ◆	■ ◆	■ ◆	■ ◆										
45			■ ◆	■ ◆	■ ◆	■ ◆	■ ◆	■ ◆										
50			■ ◆	■ ◆	■ ◆	■ ◆	■ ◆	■ ◆										
55				■ ◆	■ ◆	■ ◆		■										
60				■ ◆	■ ◆	■ ◆	■ ◆	■ ◆										
70				■ ◆	■ ◆	■ ◆	■ ◆	◆										
80				■ ◆	■ ◆	■ ◆	■ ◆	◆										
90					■ ◆	■ ◆	■ ◆	◆										
95							■											
100					■ ◆	■ ◆	■ ◆											

CLICK HERE TO RETURN TO THE CONTENTS PAGE



+ 37 064 411 786



Inquiry@invayear.com

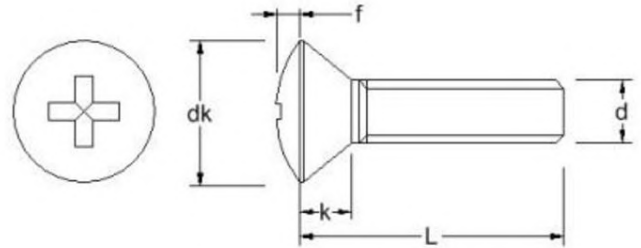

www.invayear.com

PHILLIPS RAISED COUNTERSUNK MACHINE SCREWS DIN 966 H

Material grades: A2: ■ A4: ◆

Drive	#1	#1	#1	#2	#2	#3	#4	#4									
dk	3.8	4.7	5.6	7.5	9.2	11	14.5	18									
f	0.5	0.6	0.75	1.0	1.25	1.5	2.0	2.5									
k	1.2	1.5	1.65	2.2	2.5	3.0	4.0	5.0									
Pitch	0.40	0.45	0.5	0.7	0.8	1.0	1.25	1.5									
Length/dim	M2	M2.5	M3	M4	M5	M6	M8	M10									
3	■◆																
4	■◆	■◆	■◆														
5	■◆	■◆	■◆	■◆													
6	■◆	■◆	■◆	■◆	■◆												
8	■◆	■◆	■◆	■◆	■◆	■◆											
10	■◆	■◆	■◆	■◆	■◆	■◆	■◆										
12	■◆	■◆	■◆	■◆	■◆	■◆	■◆	■◆									
14	■◆	■◆	■◆	■◆	■◆	■◆	■◆										
16	■◆	■◆	■◆	■◆	■◆	■◆	■◆	■◆									
18	■◆	■◆	■◆	■◆	■◆	■◆	■◆										
20	■◆	■◆	■◆	■◆	■◆	■◆	■◆	■◆	■								
22			■◆	■◆	■◆	■◆											
25	■◆	■◆	■◆	■◆	■◆	■◆	■◆	■◆	■								
28			■◆	■◆	■◆	■◆											
30	■◆	■◆	■◆	■◆	■◆	■◆	■◆	■◆	■◆								

CLICK HERE TO RETURN TO THE CONTENTS PAGE



+ 37 064 411 786



Inquiry@invayear.com



www.invayear.com

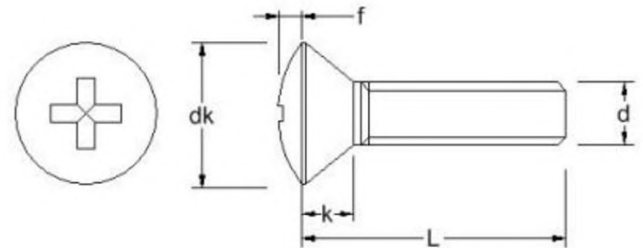

Material grades: A2: ■ A4: ◆

Drive	#1	#1	#1	#2	#2	#3	#4	#4									
dk	3.8	4.7	5.6	7.5	9.2	11	14.5	18									
f	0.5	0.6	0.75	1.0	1.25	1.5	2.0	2.5									
k	1.2	1.5	1.65	2.2	2.5	3.0	4.0	5.0									
Pitch	0.40	0.45	0.5	0.7	0.8	1.0	1.25	1.5									
Length/dim	M2	M2.5	M3	M4	M5	M6	M8	M10									
35			■ ◆	■ ◆	■ ◆	■ ◆	■ ◆	■ ◆									
40			■ ◆	■ ◆	■ ◆	■ ◆	■ ◆	■ ◆									
45			■ ◆	■ ◆	■ ◆	■ ◆	■ ◆										
50			■ ◆	■ ◆	■ ◆	■ ◆	■ ◆	■ ◆									
55				■ ◆	■ ◆	■ ◆											
60				■ ◆	■ ◆	■ ◆	■ ◆	■ ◆									
65				■ ◆	■ ◆	■ ◆											
70				■ ◆	■ ◆	■ ◆	■ ◆										
75				■ ◆	■ ◆	■ ◆											
80				■ ◆	■ ◆	■ ◆	■ ◆										
85					■ ◆	■ ◆											
90					■ ◆	■ ◆	■ ◆										
95					◆	■ ◆											
100					■ ◆	■ ◆	■ ◆										

[CLICK HERE TO RETURN TO THE CONTENTS PAGE](#)



+ 37 064 411 786



Inquiry@invayear.com

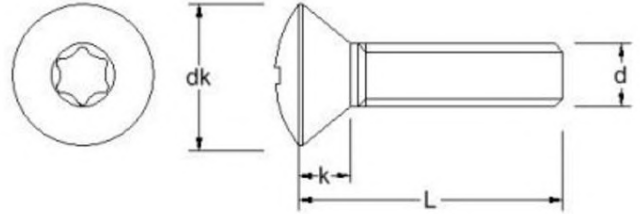

www.invayear.com

TX RAISED COUNTERSUNK MACHINE SCREWS DIN 966 TX

Material grades: A2: ■ A4: ◆

Drive	T6	T8	T10	T20	T25	T30												
dk	3.8	4.7	5.6	7.5	9.2	11												
f	0.5	0.6	0.75	1.0	1.25	1.5												
k	1.2	1.5	1.65	2.2	2.5	3.0												
Pitch	0.40	0.45	0.5	0.7	0.8	1.0												
Length/dim	M2	M2.5	M3	M4	M5	M6												
3	■ ◆																	
4	■ ◆	■ ◆	■ ◆															
5	■ ◆	■ ◆	■ ◆	■ ◆														
6	■ ◆	■ ◆	■ ◆	■ ◆	■ ◆													
8	■ ◆	■ ◆	■ ◆	■ ◆	■ ◆	■ ◆												
10	■ ◆	■ ◆	■ ◆	■ ◆	■ ◆	■ ◆	■ ◆											
12	■ ◆	■ ◆	■ ◆	■ ◆	■ ◆	■ ◆	■ ◆											
14	■ ◆	■ ◆	■ ◆	■ ◆	■ ◆	■ ◆	■ ◆											
16	■ ◆	■ ◆	■ ◆	■ ◆	■ ◆	■ ◆	■ ◆											
18	■ ◆	■ ◆	■ ◆	■ ◆	■ ◆	■ ◆	■ ◆											
20	■ ◆	■ ◆	■ ◆	■ ◆	■ ◆	■ ◆	■ ◆											
22			■ ◆	■ ◆	■ ◆	■ ◆	■ ◆											
25	■ ◆	■ ◆	■ ◆	■ ◆	■ ◆	■ ◆	■ ◆											
28			■ ◆	■ ◆	■ ◆	■ ◆	■ ◆											
30	■ ◆	■ ◆	■ ◆	■ ◆	■ ◆	■ ◆	■ ◆											

[CLICK HERE TO RETURN TO THE CONTENTS PAGE](#)



+ 37 064 411 786



Inquiry@invayear.com



www.invayear.com

DIN 966 TX

TX RAISED COUNTERSUNK MACHINE SCREWS DIN 966 TX

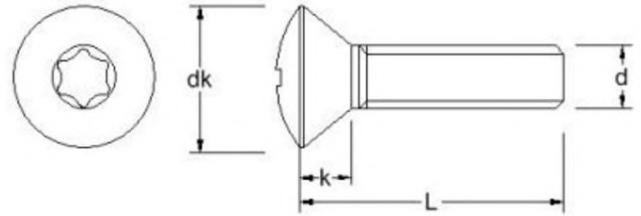

Material grades: A2: ■ A4: ◆

Drive	T6	T8	T10	T20	T25	T30												
dk	3.8	4.7	5.6	7.5	9.2	11												
f	0.5	0.6	0.75	1.0	1.25	1.5												
k	1.2	1.5	1.65	2.2	2.5	3.0												
Pitch	0.40	0.45	0.5	0.7	0.8	1.0												
Length/dim	M2	M2.5	M3	M4	M5	M6												
35			■ ◆	■ ◆	■ ◆	■ ◆												
40			■ ◆	■ ◆	■ ◆	■ ◆												
45			■ ◆	■ ◆	■ ◆	■ ◆												
50			■ ◆	■ ◆	■ ◆	■ ◆												
55				■ ◆	■ ◆	■ ◆												
60				■ ◆	■ ◆	■ ◆												
65				■ ◆	■ ◆	■ ◆												
70				■ ◆	■ ◆	■ ◆												
75				■ ◆	■ ◆	■ ◆												
80				■ ◆	■ ◆	■ ◆												
85					■ ◆	■ ◆												
90					■ ◆	■ ◆												
95					■ ◆	■ ◆												
100					■ ◆	■ ◆												

[CLICK HERE TO RETURN TO THE CONTENTS PAGE](#)



+ 37 064 411 786



Inquiry@invayear.com

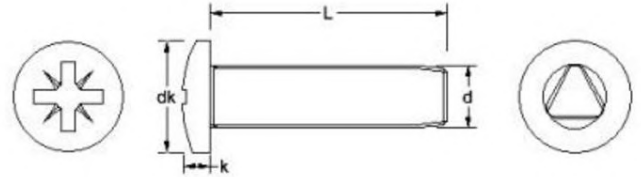

www.invayear.com

 Material grades: **A2**: ■

Drive	#1	#1	#2	#3	#3										
dk (Max)	4.7	5.3	7.64	9.14	11.57										
k (Max)	1.96	2.26	2.92	3.52	4.3										
Pitch	0.45	0.5	0.7	0.8	1.0										
Length/dim	M2.5	M3	M4	M5	M6										
5	■	■													
6	■	■	■												
8	■	■	■	■											
10	■	■	■	■	■										
12	■	■	■	■	■										
16		■	■	■	■										
20		■	■	■	■										
25			■	■	■										
30			■	■	■										

[CLICK HERE TO RETURN TO THE CONTENTS PAGE](#)



+ 37 064 411 786



Inquiry@invayear.com

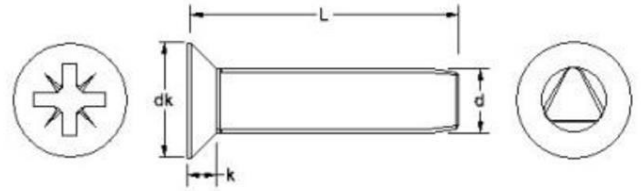

www.invayear.com

POZI COUNTERSUNK THREAD ROLLING SCREWS DIN 7500M

 Material grades: **A2**

Drive	#1	#1	#2	#2	#3										
dk	4.4	5.2	8.0	8.9	11										
k (Max)	1.5	1.65	2.7	2.7	3.0										
Pitch	0.45	0.5	0.7	0.8	1.0										
Length/dim	M2.5	M3	M4	M5	M6										
5	■	■													
6	■	■	■												
8	■	■	■	■											
10	■	■	■	■	■										
12	■	■	■	■	■										
16		■	■	■	■										
20		■	■	■	■										
25			■	■	■										
30			■	■	■										

[CLICK HERE TO RETURN TO THE CONTENTS PAGE](#)



+ 37 064 411 786



Inquiry@invayear.com



www.invayear.com

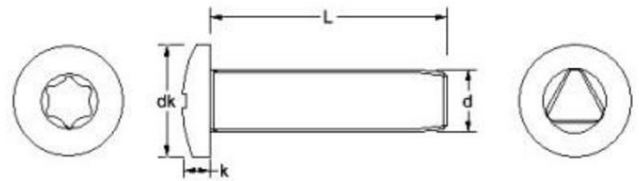

Material grades: A2: ■

dk (Max)	4.7	5.3	7.64	9.14	11.57														
k (Max)	1.96	2.26	2.92	3.52	4.30														
Pitch	0.45	0.5	0.7	0.8	1.0														
Length/dim	M2.5	M3	M4	M5	M6														
5	■	■																	
6	■	■	■																
8	■	■	■	■															
10	■	■	■	■	■														
12	■	■	■	■	■														
14				■															
16		■	■	■	■														
20		■	■	■	■														
25			■	■	■														
30			■	■	■														

[CLICK HERE TO RETURN TO THE CONTENTS PAGE](#)



+ 37 064 411 786



Inquiry@invayear.com

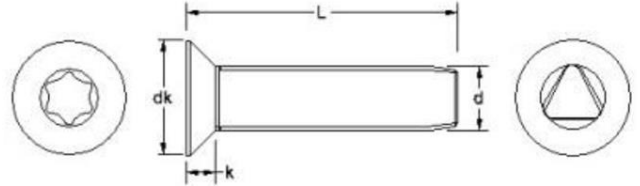

www.invayear.com

TX COUNTERSUNK THREAD ROLLING SCREWS DIN 7500M TX

 Material grades: **A2**

dk (Max)	4.4	5.2	8.04	8.94	11														
k	1.5	1.65	2.7	2.7	3.0														
Pitch	0.45	0.5	0.7	0.8	1.0														
Length/dim	M2.5	M3	M4	M5	M6														
5	■																		
6	■	■																	
8	■	■	■																
10	■	■	■	■	■														
12	■	■	■	■	■														
16		■	■	■	■														
20		■	■	■	■														
25		■	■	■	■														
30			■	■	■														

[CLICK HERE TO RETURN TO THE CONTENTS PAGE](#)



+ 37 064 411 786

Inquiry@invayear.com

www.invayear.com

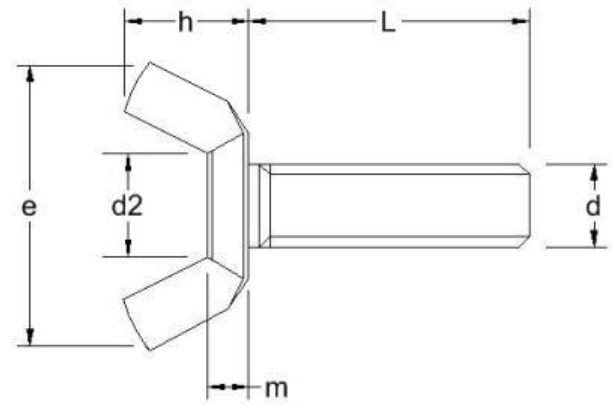

Material grades: A2: ■ A4: ◆

d2	4.5	5.2	6.7	8.4	9.1	11												
e (Min)	15.3	17.6	22.5	27.8	30.3	36.2												
h	7.2	8.6	11	13.6	14.8	17.7												
m	2.4	2.9	4.1	5.1	5.6	6.8												
Pitch	0.50	0.70	0.80	1.00	1.25	1.50												
Length/dim	M3	M4	M5	M6	M8	M10												
10	◆	◆	◆	◆	■													
12	◆	◆	◆	◆	■													
16	◆	◆	◆	◆	◆	◆												
20	◆	◆	◆	◆	◆	◆												
25	◆	◆	◆	◆	◆	◆												
30	◆	◆	◆	◆	◆	◆												
35		◆	◆	◆	◆	◆												
40		◆	◆	◆	◆	◆												
45			◆	◆	◆	◆												
50			◆	◆	◆	◆												
55					◆	◆												
60					◆	◆												

CLICK HERE TO RETURN TO THE CONTENTS PAGE



+ 37 064 411 786



Inquiry@invayear.com

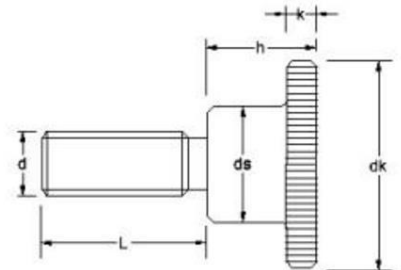

www.invayear.com

KNURLED THUMB SCREWS DIN 464

 Material grades: **A2**

dk	12	16	20	24	30	36													
ds	6	8	10	12	16	20													
h	7.5	9.5	11.5	15.0	18.0	23.0													
k	2.5	3.5	4.0	5.0	6.0	8.0													
Pitch	0.5	0.7	0.8	1.0	1.25	1.5													
Length/dim	M3	M4	M5	M6	M8	M10													
4	■																		
5	■	■																	
6	■	■	■																
8	■	■	■	■															
10	■	■	■	■															
12	■	■	■	■	■														
16	■	■	■	■	■														
20	■	■	■	■	■	■													
25		■	■	■	■	■													
30		■		■	■	■													

[CLICK HERE TO RETURN TO THE CONTENTS PAGE](#)



+ 37 064 411 786



Inquiry@invayear.com

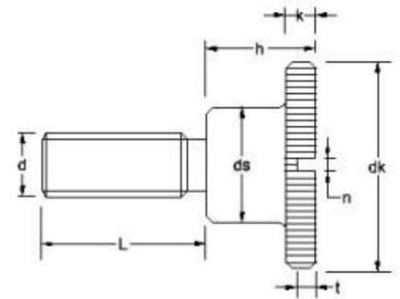
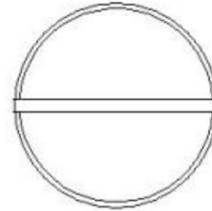

www.invayear.com

 Material grades: **A2**

dk	12	16	20	24															
ds	6	8	10	12															
h	7.5	9.5	11.5	15.0															
k	2.5	3.5	4.0	5.0															
n	0.8	1.0	1.2	1.6															
Pitch	0.5	0.7	0.8	1.0															
t (Min)	1.8	2.2	2.8	3.5															
Length/dim	M3	M4	M5	M6															
6	■	■	■																
8	■	■	■																
10	■	■	■	■															
12	■	■	■	■															
16	■	■	■	■															
20	■	■	■	■															

[CLICK HERE TO RETURN TO THE CONTENTS PAGE](#)



+ 37 064 411 786



Inquiry@invayear.com

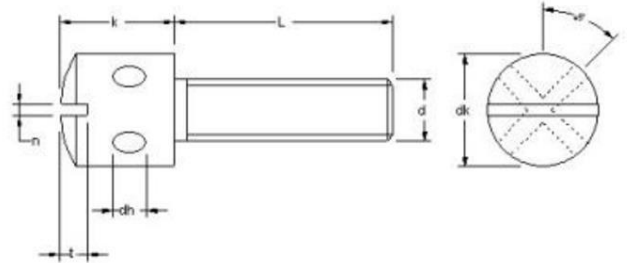

www.invayear.com

SLOTTED CAPSTAN SCREWS DIN 404

 Material grades: **A2**

dh	1.5	2.0	2.5	3.0															
dk	5.5	7.0	8.5	10.0															
k	4.0	5.0	6.5	8.0															
n	0.8	1.0	1.2	1.6															
Pitch	0.5	0.7	0.8	1.0															
t (Min)	1.0	1.4	1.7	2.2															
Length/dim	M3	M4	M5	M6															
4	■																		
5	■	■																	
6	■	■																	
8	■	■	■																
10	■	■	■	■															
12	■	■	■	■															
16	■	■	■	■															
20	■	■	■	■															
25		■	■	■															
30		■	■	■															

[CLICK HERE TO RETURN TO THE CONTENTS PAGE](#)



+ 37 064 411 786

Inquiry@invayear.com

www.invayear.com

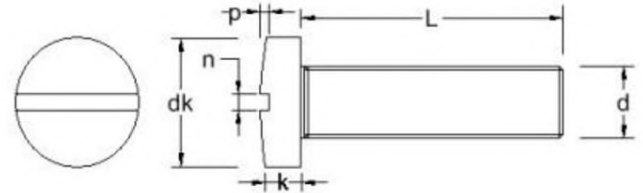
 Material grades: **A2:** ■

dk (Max)	0.096	0.118	0.118	0.140	0.140	0.161	0.161	0.183	0.183	0.205	0.226	0.226	0.270	0.313	0.313	0.357	0.414
k (Max)	0.055	0.066	0.066	0.083	0.083	0.095	0.095	0.107	0.107	0.120	0.132	0.132	0.156	0.180	0.180	0.205	0.237
n (Max)	0.023	0.026	0.026	0.031	0.031	0.035	0.035	0.039	0.039	0.043	0.048	0.048	0.054	0.060	0.060	0.067	0.075
p (Max)	0.025	0.031	0.031	0.037	0.037	0.043	0.043	0.048	0.048	0.054	0.060	0.060	0.071	0.083	0.083	0.094	0.109
Length/dim	0-80	1-64	1-72	2-56	2-64	3-48	3-56	4-40	4-48	5-40	6-32	6-40	8-32	10-24	10-32	12-24	1/4-20
1/8	■	■	■	■	■	■	■	■	■								
5/32	■																
3/16	■	■	■	■	■	■	■	■	■	■	■		■	■	■		
1/4	■	■	■	■	■	■	■	■	■	■	■	■	■	■	■		
5/16	■	■	■	■	■	■	■	■	■	■	■	■	■	■	■	■	■
3/8	■	■	■	■	■	■	■	■	■	■	■	■	■	■	■	■	■
7/16	■	■	■	■	■	■	■	■	■	■	■	■	■	■	■	■	■
1/2	■	■	■	■	■	■	■	■	■	■	■	■	■	■	■	■	■
9/16	■							■	■	■	■	■	■				
5/8	■	■	■	■	■	■	■	■	■	■	■	■	■	■	■	■	■
3/4	■	■	■	■	■	■	■	■	■	■	■	■	■	■	■	■	■
7/8	■	■	■	■	■	■	■	■	■	■	■	■	■	■	■	■	■
1	■	■	■	■	■	■	■	■	■	■	■	■	■	■	■	■	■
1.1/8											■	■	■				
1.1/4						■		■		■	■	■	■	■	■	■	■
1.1/2						■		■		■	■	■	■	■	■	■	■

CLICK HERE TO RETURN TO THE CONTENTS PAGE



+ 37 064 411 786



Inquiry@invayear.com

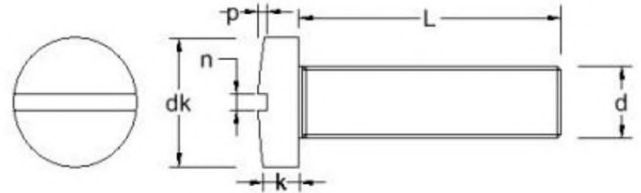

www.invayear.com

SLOT FILLISTER MACHINE SCREWS ANSI B18.6.3

 Material grades: **A2**: ■

dk (Max)	0.414	0.518	0.622																
k (Max)	0.237	0.295	0.355																
n (Max)	0.075	0.084	0.094																
p (Max)	0.109	0.137	0.164																
Length/dim	1/4-28	5/16-18	3/8-16																
1/8																			
5/32																			
3/16																			
1/4																			
5/16	■																		
3/8	■	■																	
7/16																			
1/2	■	■	■																
9/16																			
5/8	■	■	■																
3/4	■	■	■																
7/8	■	■	■																
1	■	■	■																
1.1/8																			
1.1/4	■	■	■																
1.1/2	■	■	■																

CLICK HERE TO RETURN TO THE CONTENTS PAGE



+ 37 064 411 786



Inquiry@invayear.com

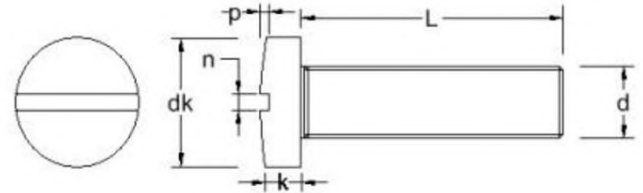

www.invayear.com

 Material grades: **A2**

Material grades: A2	0.096	0.118	0.118	0.140	0.140	0.161	0.161	0.183	0.183	0.205	0.226	0.226	0.270	0.313	0.313	0.357	0.414
dk (Max)	0.096	0.118	0.118	0.140	0.140	0.161	0.161	0.183	0.183	0.205	0.226	0.226	0.270	0.313	0.313	0.357	0.414
k (Max)	0.055	0.066	0.066	0.083	0.083	0.095	0.095	0.107	0.107	0.120	0.132	0.132	0.156	0.180	0.180	0.205	0.237
n (Max)	0.023	0.026	0.026	0.031	0.031	0.035	0.035	0.039	0.039	0.043	0.048	0.048	0.054	0.060	0.060	0.067	0.075
p (Max)	0.025	0.031	0.031	0.037	0.037	0.043	0.043	0.048	0.048	0.054	0.060	0.060	0.071	0.083	0.083	0.094	0.109
Length/dim	0-80	1-64	1-72	2-56	2-64	3-48	3-56	4-40	4-48	5-40	6-32	6-40	8-32	10-24	10-32	12-24	1/4-20
1.3/4											■	■	■	■	■	■	■
2											■	■	■	■	■	■	■
2.1/4														■	■		
2.1/2														■	■	■	■
2.3/4														■	■		
3														■	■	■	■
3.1/2																	■
4																	■
4.1/2																	
5																	
6																	

CLICK HERE TO RETURN TO THE CONTENTS PAGE



+ 37 064 411 786



Inquiry@invayear.com

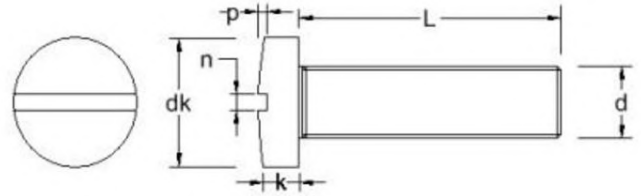

www.invayear.com

SLOT FILLISTER MACHINE SCREWS ANSI B18.6.3

 Material grades: **A2**

dk (Max)	0.414	0.518	0.622																	
k (Max)	0.237	0.295	0.355																	
n (Max)	0.075	0.084	0.094																	
p (Max)	0.109	0.137	0.164																	
Length/dim	1/4-28	5/16-18	3/8-16																	
1.3/4	■	■	■																	
2	■	■	■																	
2.1/4																				
2.1/2	■	■	■																	
2.3/4																				
3	■	■	■																	
3.1/2	■	■	■																	
4	■	■	■																	
4.1/2		■																		
5		■	■																	
6			■																	

CLICK HERE TO RETURN TO THE CONTENTS PAGE



+ 37 064 411 786



Inquiry@invayear.com



www.invayear.com

SLOT BINDING MACHINE SCREWS ANSI B18.6.3

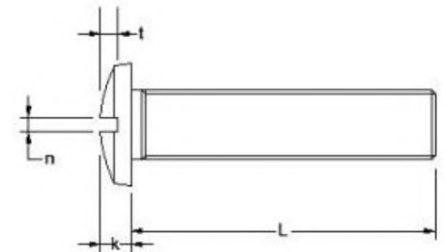
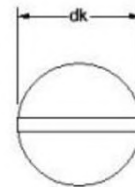

Material grades: A2: ■

dk	0.181	0.208	0.235	0.263	0.290	0.344	0.399	0.399	0.525	0.525	0.656	0.788				
k (Max)	0.050	0.059	0.068	0.078	0.087	0.105	0.123	0.123	0.165	0.165	0.209	0.253				
n (Max)	0.031	0.035	0.039	0.043	0.048	0.054	0.060	0.060	0.075	0.075	0.084	0.094				
p (Max)	0.030	0.036	0.042	0.048	0.053	0.065	0.077	0.077	0.105	0.105	0.134	0.163				
Length/dim	2-56	3-48	4-40	5-40	6-32	8-32	10-24	10-32	1/4-20	1/4-28	5/16-18	3/8-16				
1/8	■	■	■	■												
3/16	■	■	■	■	■											
1/4	■	■	■	■	■	■	■	■								
5/16	■	■	■	■	■	■	■	■	■	■						
3/8	■	■	■	■	■	■	■	■	■	■	■					
7/16	■	■	■	■	■	■	■	■	■	■	■					
1/2	■	■	■	■	■	■	■	■	■	■	■	■				
9/16	■	■	■	■	■											
5/8	■	■	■	■	■	■	■	■	■	■	■	■				
3/4	■	■	■	■	■	■	■	■	■	■	■	■				
7/8	■	■	■	■	■	■	■	■	■	■	■	■				
1	■	■	■	■	■	■	■	■	■	■	■	■				
1.1/4			■	■	■	■	■	■	■	■	■	■				
1.1/2			■	■	■	■	■	■	■	■	■	■				
1.3/4					■	■	■	■	■	■	■	■				
2					■	■	■	■	■	■	■	■				
2.1/4									■	■	■	■				
2.1/2									■	■	■	■				
2.3/4									■	■	■	■				
3									■	■	■	■				
3.1/2													■			
4																■

[CLICK HERE TO RETURN TO THE CONTENTS PAGE](#)



+ 37 064 411 786



Inquiry@invayear.com

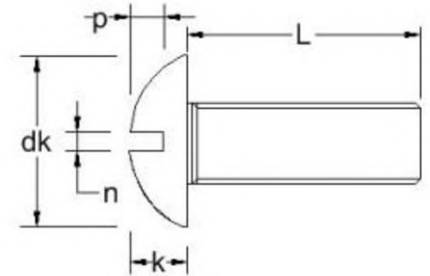
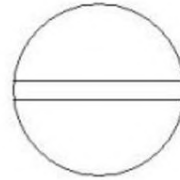

www.invayear.com

SLOT ROUND MACHINE SCREWS ANSI B18.6.3

 Material grades: **A2**: ■

dk (Max)	0.162	0.187	0.211	0.236	0.260	0.309	0.359	0.359	0.472	0.472	0.590	0.708						
k (Max)	0.069	0.078	0.086	0.095	0.103	0.120	0.137	0.137	0.175	0.175	0.216	0.256						
n (Max)	0.031	0.035	0.039	0.043	0.048	0.054	0.060	0.060	0.075	0.075	0.084	0.094						
p (Max)	0.048	0.053	0.058	0.063	0.068	0.077	0.087	0.087	0.109	0.109	0.132	0.155						
Length/dim	2-56	3-48	4-40	5-40	6-32	8-32	10-24	10-32	1/4-20	1/4-28	5/16-18	3/8-16						
1/8	■	■	■	■	■													
3/16	■	■	■	■	■													
1/4	■	■	■	■	■	■	■	■										
5/16	■	■	■	■	■	■	■	■	■	■								
3/8	■	■	■	■	■	■	■	■	■	■	■							
7/16	■	■	■	■	■	■	■	■	■	■	■	■						
1/2	■	■	■	■	■	■	■	■	■	■	■	■	■					
9/16	■	■	■	■	■													
5/8	■	■	■	■	■	■	■	■	■	■	■	■	■					
3/4	■	■	■	■	■	■	■	■	■	■	■	■	■	■				
7/8	■	■	■	■	■	■	■	■	■	■	■	■	■	■				
1	■	■	■	■	■	■	■	■	■	■	■	■	■	■				
1.1/4			■	■	■	■	■	■	■	■	■	■	■	■				
1.1/2			■	■	■	■	■	■	■	■	■	■	■	■				
1.3/4					■	■	■	■	■	■	■	■	■	■				
2					■	■	■	■	■	■	■	■	■	■				
2.1/4							■	■	■	■	■	■	■	■				
2.1/2							■	■	■	■	■	■	■	■				
2.3/4							■	■	■	■	■	■	■	■				
3							■	■	■	■	■	■	■	■				
3.1/2																		■
4																		■

[CLICK HERE TO RETURN TO THE CONTENTS PAGE](#)

+ 37 064 411 786

Inquiry@invayear.com

www.invayear.com

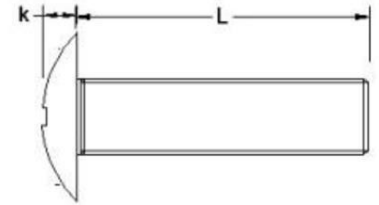

Material grades: A2: ■

Drive	#2	#2	#2	#2	#3	#3	#4	#4									
dk (Max)	0.321	0.384	0.448	0.448	0.573	0.573	0.698	0.823									
k (Max)	0.086	0.102	0.128	0.128	0.150	0.150	0.183	0.215									
Length/dim	6-32	8-32	10-24	10-32	1/4-20	1/4-28	5/16-18	3/8-16									
1/4	■	■	■	■													
5/16	■	■	■	■													
3/8	■	■	■	■	■	■											
7/16	■	■	■	■	■	■											
1/2	■	■	■	■	■	■	■	■									
5/8	■	■	■	■	■	■	■	■	■								
3/4	■	■	■	■	■	■	■	■	■								
7/8	■	■	■	■	■	■	■	■	■								
1	■	■	■	■	■	■	■	■	■								
1.1/4		■	■	■	■	■	■	■	■								
1.1/2		■	■	■	■	■	■	■	■								
1.3/4			■	■	■	■	■	■	■								
2			■	■	■	■	■	■	■								
2.1/2					■	■	■	■	■								
3					■	■	■	■	■								

[CLICK HERE TO RETURN TO THE CONTENTS PAGE](#)



+ 37 064 411 786



Inquiry@invayear.com

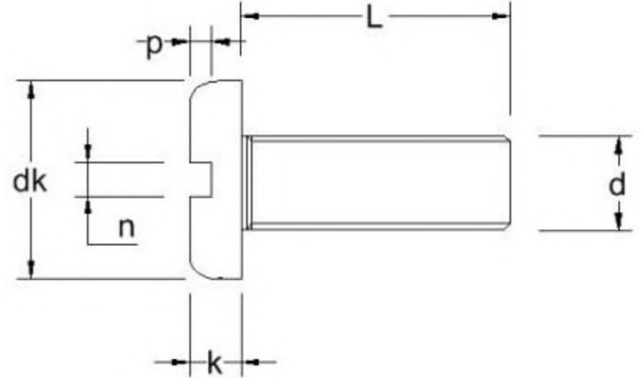

www.invayear.com

SLOT PAN MACHINE SCREWS ANSI B18.6.3

Material grades: A2: ■ A4: ◆

dk (Max)	0.116	0.142	0.142	0.167	0.193	0.219	0.219	0.245	0.270	0.322	0.373	0.373	0.425	0.492	0.492	0.615	0.740
k (Max)	0.039	0.046	0.046	0.053	0.060	0.068	0.068	0.075	0.082	0.096	0.110	0.110	0.125	0.144	0.144	0.178	0.212
n (Max)	0.023	0.026	0.026	0.031	0.035	0.039	0.039	0.043	0.048	0.054	0.060	0.060	0.067	0.075	0.075	0.084	0.094
p (Max)	0.022	0.027	0.027	0.031	0.036	0.040	0.040	0.045	0.050	0.058	0.068	0.068	0.077	0.087	0.087	0.106	0.124
Length/dim	0-80	1-64	1-72	2-56	3-48	4-40	4-48	5-40	6-32	8-32	10-24	10-32	12-24	1/4-20	1/4-28	5/16-18	3/8-16
1/8	■	■	■	■	■	◆	■		◆								
3/16	■	■	■	■	■	◆	■	■	◆	◆	◆	◆					
1/4	■	■	■	■	■	◆	■	■	◆	◆	◆	◆	■	◆	■		
5/16	■	■	■	■	■	◆	■	■	◆	◆	◆	◆	■	◆	■		
3/8	■	■	■	■	■	◆	■	■	◆	◆	◆	◆	■	◆	■	◆	
7/16	■	■	■	■	■	◆	■	■	◆	◆	◆	◆	■	◆	■		
1/2	■	■	■	■	■	◆	■	■	◆	◆	◆	◆	■	◆	■	◆	◆
9/16	■	■	■	■		◆	■	■	◆	◆							
5/8	■	■	■	■	■	◆	■	■	◆	◆	◆	◆	■	◆	■	◆	◆
3/4	■	■	■	■	■	◆	■	■	◆	◆	◆	◆	■	◆	■	◆	◆
7/8	■	■	■	■	■	◆	■	■	◆	◆	◆	◆	■	◆	■	◆	◆
1	■	■	■	■	■	◆	■	■	◆	◆	◆	◆	■	◆	■	◆	◆
1.1/8						■											
1.1/4				■	■	■		■	◆	◆	■	■	■	◆	■	■	■
1.1/2				■	■	■		■	◆	◆	■	■	■	◆	■	■	■
1.3/4						■			◆	◆	■	■	■	◆	■	■	■

CLICK HERE TO RETURN TO THE CONTENTS PAGE



+ 37 064 411 786



Inquiry@invayear.com



www.invayear.com

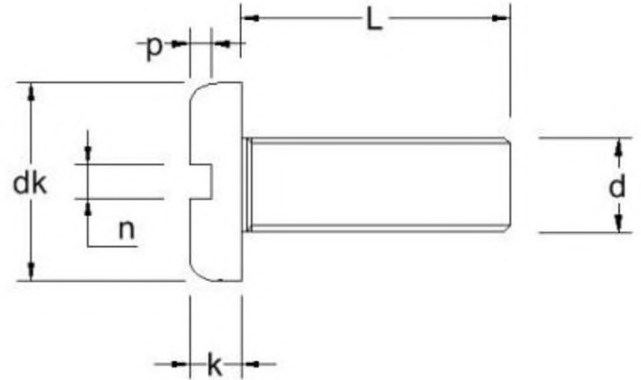

Material grades: A2: ■ A4: ◆

dk (Max)	0.116	0.142	0.142	0.167	0.193	0.219	0.219	0.245	0.270	0.322	0.373	0.373	0.425	0.492	0.492	0.615	0.740
k (Max)	0.039	0.046	0.046	0.053	0.060	0.068	0.068	0.075	0.082	0.096	0.110	0.110	0.125	0.144	0.144	0.178	0.212
n (Max)	0.023	0.026	0.026	0.031	0.035	0.039	0.039	0.043	0.048	0.054	0.060	0.060	0.067	0.075	0.075	0.084	0.094
p (Max)	0.022	0.027	0.027	0.031	0.036	0.040	0.040	0.045	0.050	0.058	0.068	0.068	0.077	0.087	0.087	0.106	0.124
Length/dim	0-80	1-64	1-72	2-56	3-48	4-40	4-48	5-40	6-32	8-32	10-24	10-32	12-24	1/4-20	1/4-28	5/16-18	3/8-16
2						■			■◆	■◆	■	■	■	■◆	■	■	■
2.1/4									■	■	■	■					
2.1/2									■	■	■	■	■	■			■
2.3/4									■	■	■	■					
3									■	■	■	■	■	■			■
3.1/2														■			■
4														■			■
4.1/2																	■
5																	■
6																	■

[CLICK HERE TO RETURN TO THE CONTENTS PAGE](#)

+ 37 064 411 786

Inquiry@invayear.com

www.invayear.com

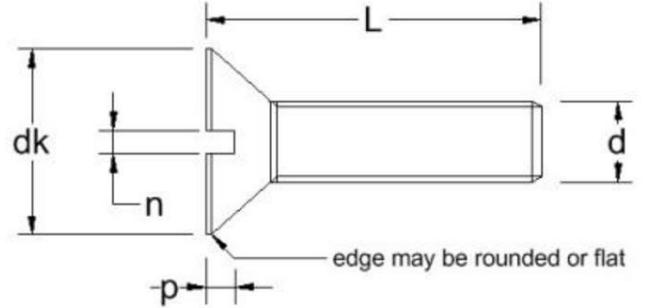
SLOT COUNTERSUNK MACHINE SCREWS ANSI B18.6.3

Material grades: A2: ■ A4: ◆

dk (Max)	0.112	0.137	0.137	0.162	0.162	0.212	0.237	0.262	0.262	0.312	0.362	0.362	0.412	0.477	0.477	0.597	0.597
k	0.035	0.043	0.043	0.051	0.051	0.067	0.075	0.083	0.083	0.100	0.116	0.116	0.132	0.153	0.153	0.191	0.191
L1	1/8	1/8	1/8	1/8	1/8	3/16	3/16	3/16	3/16	1/4	5/16	5/16	3/8	7/16	7/16	1/2	1/2
n (Max)	0.023	0.026	0.026	0.031	0.031	0.039	0.043	0.048	0.048	0.054	0.060	0.060	0.067	0.075	0.075	0.084	0.084
τ (Max)	0.015	0.019	0.019	0.023	0.023	0.030	0.034	0.038	0.038	0.045	0.053	0.053	0.060	0.070	0.070	0.088	0.088
Length/dim	0-80	1-64	1-72	2-56	2-64	4-40	5-40	6-32	6-40	8-32	10-24	10-32	12-24	1/4-20	1/4-28	5/16-18	5/16-24
3/32	■																
1/8	■	■	■	■	■	◆		◆	■								
5/32	■	■	■	■	■												
3/16	■	■	■	■	■	◆	■	◆		◆	◆	◆					
1/4	■	■	■	■	■	◆	■	◆	■	◆	◆	◆	■	◆	◆		
5/16	■	■	■	■	■	◆	■	◆	■	◆	◆	◆	■	◆	◆		
3/8	■	■	■	■	■	◆	■	◆	■	◆	◆	◆	■	◆	◆	◆	◆
7/16	■	■	■	■	■		■	◆	■	◆	◆	◆	■	◆	◆		
1/2	■	■	■	■	■	◆	■	◆	■	◆	◆	◆	■	◆	◆	◆	◆
9/16	■	■	■	■	■	◆	■	◆	■	◆							
5/8	■	■	■	■	■	◆	■	◆	■	◆	◆	◆	■	◆	◆	◆	◆
3/4	■	■	■	■	■	◆	■	◆	■	◆	◆	◆	■	◆	◆	◆	◆
7/8	■	■	■	■	■	◆	■	◆	■	◆	◆	◆	■	◆	◆	◆	◆
1	■	■	■	■	■	◆	■	◆	■	◆	◆	◆	■	◆	◆	◆	◆
1.1/4				■	■	◆	■	◆	■	◆	◆	◆	■	◆	■	◆	■

CLICK HERE TO RETURN TO THE CONTENTS PAGE



+ 37 064 411 786



Inquiry@invayear.com



www.invayear.com

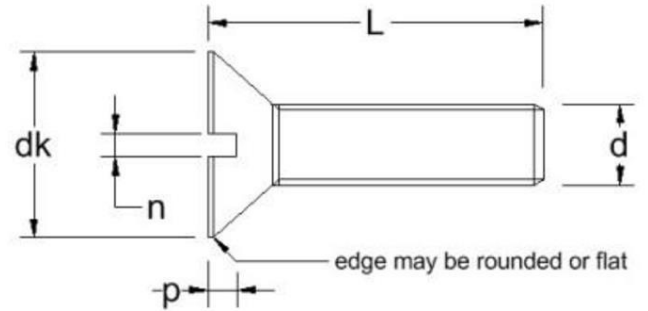

Material grades: A2: ■ A4: ◆

Material grades: A2: ■ A4: ◆																				
dk (Max)	0.717	0.815	1.050																	
k	0.230	0.223	0.298																	
L1	9/16	3/4	*																	
n (Max)	0.094	0.106	0.133																	
τ (Max)	0.106	0.103	0.137																	
Length/dim	3/8-16	1/2-13	5/8-11																	
3/32																				
1/8																				
5/32																				
3/16																				
1/4																				
5/16																				
3/8																				
7/16																				
1/2	■ ◆																			
9/16																				
5/8	■ ◆	■ ◆																		
3/4	■ ◆	■ ◆																		
7/8	■ ◆	■ ◆																		
1	■ ◆	■ ◆	■ ◆																	
1.1/4	■ ◆	■ ◆	■ ◆																	

CLICK HERE TO RETURN TO THE CONTENTS PAGE



+ 37 064 411 786



Inquiry@invayear.com

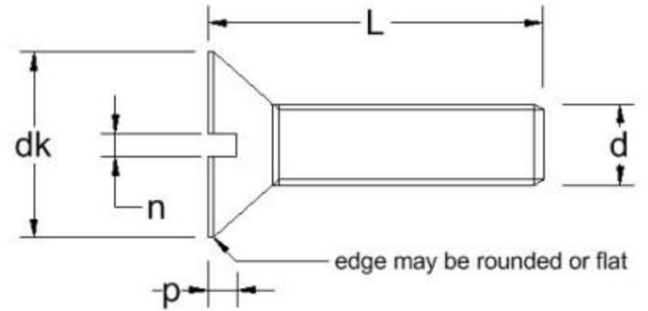

www.invayear.com

SLOT COUNTERSUNK MACHINE SCREWS ANSI B18.6.3

Material grades: A2: ■ A4: ◆

dk (Max)	0.112	0.137	0.137	0.162	0.162	0.212	0.237	0.262	0.262	0.312	0.362	0.362	0.412	0.477	0.477	0.597	0.597
k	0.035	0.043	0.043	0.051	0.051	0.067	0.075	0.083	0.083	0.100	0.116	0.116	0.132	0.153	0.153	0.191	0.191
L1	1/8	1/8	1/8	1/8	1/8	3/16	3/16	3/16	3/16	1/4	5/16	5/16	3/8	7/16	7/16	1/2	1/2
n (Max)	0.023	0.026	0.026	0.031	0.031	0.039	0.043	0.048	0.048	0.054	0.060	0.060	0.067	0.075	0.075	0.084	0.084
τ (Max)	0.015	0.019	0.019	0.023	0.023	0.030	0.034	0.038	0.038	0.045	0.053	0.053	0.060	0.070	0.070	0.088	0.088
Length/dim	0-80	1-64	1-72	2-56	2-64	4-40	5-40	6-32	6-40	8-32	10-24	10-32	12-24	1/4-20	1/4-28	5/16-18	5/16-24
1.1/2				■	■	■◆	■	■◆	■	■◆	■◆	■◆	■	■◆	■	■◆	■
1.3/4						■◆		■◆	■	■◆	■◆	■◆	■	■◆	■	■◆	■
2						■◆		■◆	■	■◆	■◆	■◆	■	■◆	■	■◆	■
2.1/4								■◆		■◆	■◆	■◆		■◆			
2.1/2								■◆		■◆	■◆	■◆	■	■◆			■◆
2.3/4								■◆		■◆	■◆	■◆					
3								■◆		■◆	■◆	■◆	■	■◆		■◆	
3.1/2														■◆		■◆	
4														■◆		■◆	
4.1/2																■◆	
5																■◆	

CLICK HERE TO RETURN TO THE CONTENTS PAGE



+ 37 064 411 786



Inquiry@invayear.com



www.invayear.com

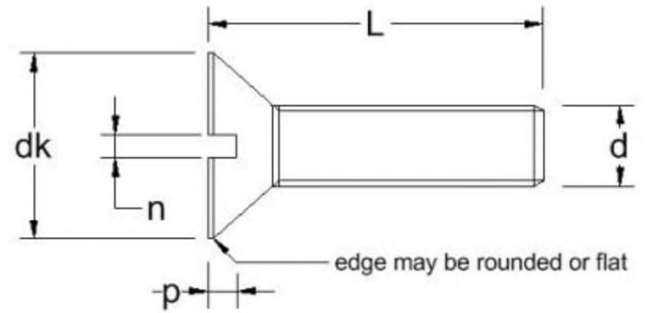

Material grades: A2: ■ A4: ◆

dk (Max)	0.717	0.815	1.050																
k	0.230	0.223	0.298																
L1	9/16	3/4	*																
n (Max)	0.094	0.106	0.133																
t (Max)	0.106	0.103	0.137																
Length/dim	3/8-16	1/2-13	5/8-11																
1.1/2	■ ◆	■ ◆	■ ◆																
1.3/4	■ ◆	■ ◆	■ ◆																
2	■ ◆	■ ◆	■ ◆																
2.1/4	■ ◆	■ ◆	■ ◆																
2.1/2	■ ◆	■ ◆	■ ◆																
2.3/4																			
3	■ ◆	■ ◆	■ ◆																
3.1/2	■ ◆	■ ◆	■ ◆																
4	■ ◆	■ ◆	■ ◆																
4.1/2																			
5	■ ◆	■ ◆	■ ◆																
6	■ ◆	■ ◆	■ ◆																

CLICK HERE TO RETURN TO THE CONTENTS PAGE



+ 37 064 411 786



Inquiry@invayear.com

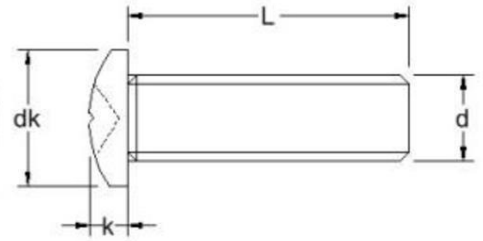
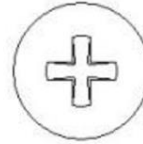

www.invayear.com

PHILLIPS PAN MACHINE SCREWS ANSI B18.6.3

Material grades: A2: ■ A4: ◆

Drive	#0	#0	#0	#1	#1	#1	#1	#1	#2	#2	#2	#2	#2	#3	#3	#3	#4
dk (Max)	0.116	0.142	0.142	0.167	0.193	0.193	0.219	0.219	0.245	0.270	0.322	0.373	0.373	0.425	0.492	0.492	0.615
k (Max)	0.044	0.053	0.053	0.062	0.071	0.071	0.080	0.080	0.089	0.097	0.115	0.133	0.133	0.151	0.175	0.175	0.218
Length/dim	0-80	1-64	1-72	2-56	3-48	3-56	4-40	4-48	5-40	6-32	8-32	10-24	10-32	12-24	1/4-20	1/4-28	5/16-18
1/8	■	■	■	◆	◆	■	◆	■	◆	◆							
5/32				◆			◆	■									
3/16	■	■	■	◆	◆	■	◆	■	◆	◆	◆	◆	◆				
1/4	■	■	■	◆	◆	■	◆	■	◆	◆	◆	◆	◆				
5/16	■	■	■	◆	◆	■	◆	■	◆	◆	◆	◆	◆	■	◆	◆	
3/8	■	■	■	◆	◆	■	◆	■	◆	◆	◆	◆	◆	■	◆	◆	◆
7/16	■	■	■	◆	◆	■	◆	■	◆	◆	◆	◆	◆	■	◆	◆	◆
1/2	■	■	■	◆	◆	■	◆	■	◆	◆	◆	◆	◆	■	◆	◆	◆
9/16				◆			◆	■		◆	◆	◆	◆				
5/8	■	■	■	◆	◆	■	◆	■	◆	◆	◆	◆	◆	■	◆	◆	◆
3/4	■	■	■	◆	◆	■	◆	■	◆	◆	◆	◆	◆	■	◆	◆	◆
7/8	■	■	■	◆	◆	■	◆	■	◆	◆	◆	◆	◆	■	◆	◆	◆
1	■	■	■	◆	◆	■	◆	■	◆	◆	◆	◆	◆	■	◆	◆	◆
1.1/8				◆			◆			◆	◆	◆	◆		◆	■	
1.1/4				◆			◆		◆	◆	◆	◆	◆	■	◆	■	◆
1.3/8											◆	◆	◆				
1.1/2				◆			◆		◆	◆	◆	◆	◆	■	◆	■	◆

CLICK HERE TO RETURN TO THE CONTENTS PAGE



+ 37 064 411 786



Inquiry@invayear.com



www.invayear.com

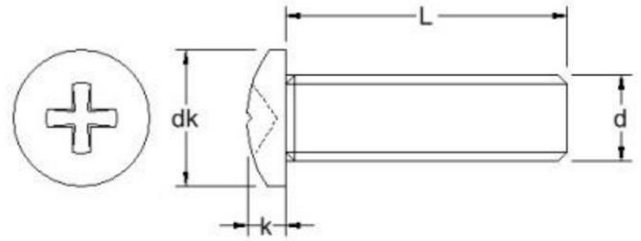

Material grades: A2: ■ A4: ◆

Drive	#4																		
dk (Max)	0.740																		
k (Max)	0.261																		
Length/dim	3/8-16																		
1/8																			
5/32																			
3/16																			
1/4																			
5/16																			
3/8																			
7/16																			
1/2	■ ◆																		
9/16																			
5/8	■ ◆																		
3/4	■ ◆																		
7/8	■ ◆																		
1	■ ◆																		
1.1/8																			
1.1/4	■ ◆																		
1.3/8																			
1.1/2	■ ◆																		

[CLICK HERE TO RETURN TO THE CONTENTS PAGE](#)



+ 37 064 411 786



Inquiry@invayear.com

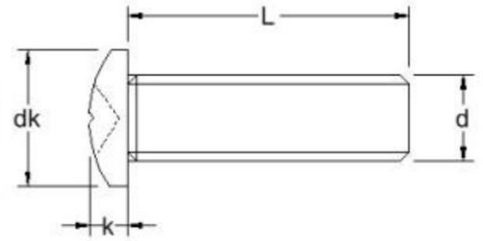
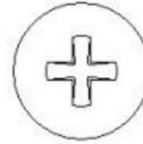

www.invayear.com

PHILLIPS PAN MACHINE SCREWS ANSI B18.6.3

Material grades: A2: ■ A4: ◆

Drive	#0	#0	#0	#1	#1	#1	#1	#1	#2	#2	#2	#2	#2	#3	#3	#3	#4
dk (Max)	0.116	0.142	0.142	0.167	0.193	0.193	0.219	0.219	0.245	0.270	0.322	0.373	0.373	0.425	0.492	0.492	0.615
k (Max)	0.044	0.053	0.053	0.062	0.071	0.071	0.080	0.080	0.089	0.097	0.115	0.133	0.133	0.151	0.175	0.175	0.218
Length/dim	0-80	1-64	1-72	2-56	3-48	3-56	4-40	4-48	5-40	6-32	8-32	10-24	10-32	12-24	1/4-20	1/4-28	5/16-18
1.5/8												■◆	■◆				
1.3/4							■◆		■◆	■◆	■◆	■◆	■◆	■	■◆	■	■◆
2							■◆		■◆	■◆	■◆	■◆	■◆	■	■◆	■	■◆
2.1/4										■◆	■◆	■◆	■◆		■◆	■	■◆
2.1/2							■◆			■◆	■◆	■◆	■◆	■	■◆	■	■◆
2.3/4										■◆	■◆	■◆	■◆		■◆	■	■◆
3							■◆			■◆	■◆	■◆	■◆	■	■◆	■	■◆
3.1/4												■◆					
3.1/2											■◆	■◆	■◆		■		■◆
4											■◆	■◆	■◆		■		■◆
4.1/2															■		■
5															■		■
6															■		■

CLICK HERE TO RETURN TO THE CONTENTS PAGE



+ 37 064 411 786



Inquiry@invayear.com



www.invayear.com

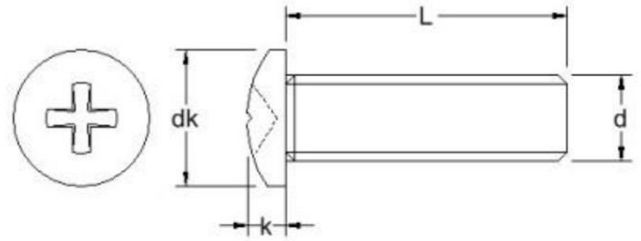

Material grades: A2: ■ A4: ◆

Drive	#4																		
dk (Max)	0.740																		
k (Max)	0.261																		
Length/dim	3/8-16																		
1.5/8																			
1.3/4	■ ◆																		
2	■ ◆																		
2.1/4																			
2.1/2	■ ◆																		
2.3/4																			
3	■ ◆																		
3.1/4																			
3.1/2	■ ◆																		
4	■ ◆																		
4.1/2	■																		
5	■																		
6	■																		

CLICK HERE TO RETURN TO THE CONTENTS PAGE



+ 37 064 411 786



Inquiry@invayear.com

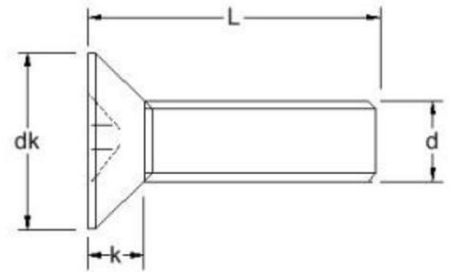
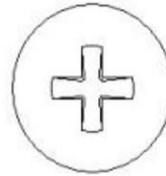

www.invayear.com

PHILLIPS COUNTERSUNK MACHINE SCREWS ANSI B18.6.3

Material grades: A2: ■ A4: ◆

Drive	#0	#0	#0	#1	#1	#1	#1	#1	#2	#2	#2	#2	#2	#3	#3	#3	#4
dk (Max)	0.112	0.137	0.137	0.162	0.187	0.187	0.212	0.212	0.237	0.262	0.312	0.362	0.362	0.412	0.477	0.477	0.597
k	0.035	0.043	0.043	0.051	0.059	0.059	0.067	0.067	0.075	0.083	0.100	0.116	0.116	0.132	0.153	0.153	0.191
L1	1/8	1/8	1/8	1/8	1/8	1/8	3/16	3/16	3/16	3/16	1/4	5/16	5/16	3/8	7/16	7/16	1/2
Length/dim	0-80	1-64	1-72	2-56	3-48	3-56	4-40	4-48	5-40	6-32	8-32	10-24	10-32	12-24	1/4-20	1/4-28	5/16-18
1/8	■	■	■	◆			◆	■									
5/32				◆													
3/16	■	■	■	◆	■	■	◆	■	■	◆							
1/4	■	■	■	◆	■	■	◆	■	■	◆	◆	◆	◆				
5/16	■	■	■	◆	■	■	◆	■	■	◆	◆	◆	◆	■			
3/8	■	■	■	◆	■	■	◆	■	■	◆	◆	◆	◆	■	◆	◆	◆
7/16	■	■	■	◆	■		◆	■	■	◆	◆	◆	◆	■	◆	◆	◆
1/2	■	■	■	◆	■	■	◆	■	■	◆	◆	◆	◆	■	◆	◆	◆
9/16	■	■	■	◆			◆	■		◆							
5/8	■	■	■	◆	■	■	◆	■	■	◆	◆	◆	◆	■	◆	◆	◆
3/4	■	■	■	◆	■	■	◆	■	■	◆	◆	◆	◆	■	◆	◆	◆
7/8		■	■	◆	■	■	◆	■	■	◆	◆	◆	◆	■	◆	◆	◆
1		■	■	◆	■	■	◆	■	■	◆	◆	◆	◆	■	◆	◆	◆
1.1/8				◆													
1.1/4				◆	■		◆	■	■	◆	◆	◆	◆	■	◆	■	◆
1.1/2				◆	■		◆	■	■	◆	◆	◆	◆	■	◆	■	◆

CLICK HERE TO RETURN TO THE CONTENTS PAGE



+ 37 064 411 786



Inquiry@invayear.com

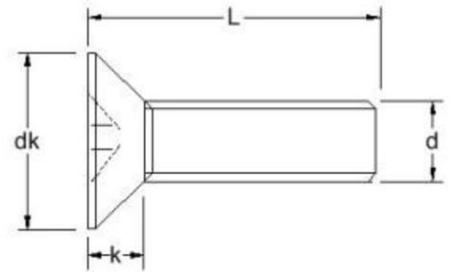
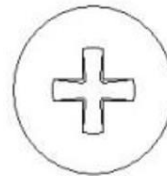

www.invayear.com

PHILLIPS COUNTERSUNK MACHINE SCREWS ANSI B18.6.3

Material grades: A2: ■ A4: ◆

Drive	#0	#0	#0	#1	#1	#1	#1	#1	#2	#2	#2	#2	#2	#3	#3	#3	#4
dk (Max)	0.112	0.137	0.137	0.162	0.187	0.187	0.212	0.212	0.237	0.262	0.312	0.362	0.362	0.412	0.477	0.477	0.597
k	0.035	0.043	0.043	0.051	0.059	0.059	0.067	0.067	0.075	0.083	0.100	0.116	0.116	0.132	0.153	0.153	0.191
L1	1/8	1/8	1/8	1/8	1/8	1/8	3/16	3/16	3/16	3/16	1/4	5/16	5/16	3/8	7/16	7/16	1/2
Length/dim	0-80	1-64	1-72	2-56	3-48	3-56	4-40	4-48	5-40	6-32	8-32	10-24	10-32	12-24	1/4-20	1/4-28	5/16-18
1.3/4							■◆	■	■	■◆	■◆	■◆	■◆	■	■◆	■	■◆
2							■◆	■	■	■◆	■◆	■◆	■◆	■	■◆	■	■◆
2.1/4															■◆	■	■◆
2.1/2										■◆	■◆	■◆	■◆	■	■◆	■	■◆
2.3/4															■◆	■	
3										■◆	■◆	■◆	■◆	■	■◆	■	■◆
3.1/2											■◆	■◆	■◆		■◆		■◆
4											■◆	■◆	■◆		■◆		■◆
5															■◆		■◆
6																	■◆

CLICK HERE TO RETURN TO THE CONTENTS PAGE



+ 37 064 411 786



Inquiry@invayear.com

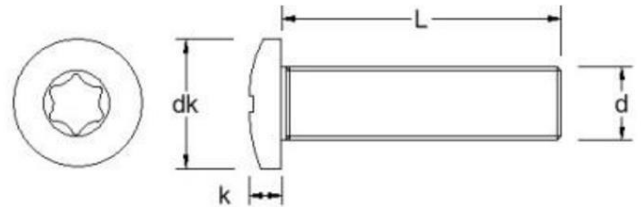

www.invayear.com

TX PAN MACHINE SCREWS

 Material grades: **A2**: ■

dk (Max)	0.219	0.270	0.322	0.373	0.373	0.492	0.615	0.740									
k (Max)	0.080	0.097	0.115	0.133	0.133	0.175	0.218	0.261									
Length/dim	4-40	6-32	8-32	10-24	10-32	1/4-20	5/16-18	3/8-16									
1/4	■	■	■														
5/16	■																
3/8	■	■	■														
1/2	■	■	■	■	■	■											
3/4		■	■	■	■	■	■	■									
1		■	■	■	■	■	■	■									
1.1/4				■	■	■	■	■									
1.1/2				■	■	■		■									

CLICK HERE TO RETURN TO THE CONTENTS PAGE



+ 37 064 411 786



Inquiry@invayear.com

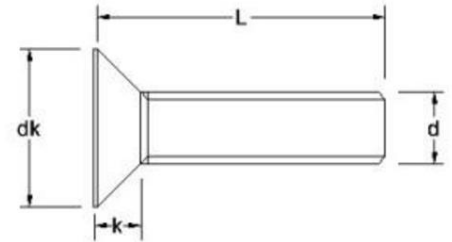
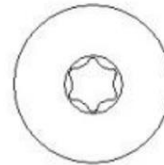

www.invayear.com

 Material grades: **A2**: ■

dk (Max)	0.212	0.262	0.312	0.362	0.362	0.477											
k	0.067	0.083	0.100	0.116	0.116	0.153											
Length/dim	4-40	6-32	8-32	10-24	10-32	1/4-20											
1/4	■	■															
3/8	■	■	■														
1/2	■	■	■	■	■	■											
3/4		■		■	■	■											

CLICK HERE TO RETURN TO THE CONTENTS PAGE



+ 37 064 411 786



Inquiry@invayear.com

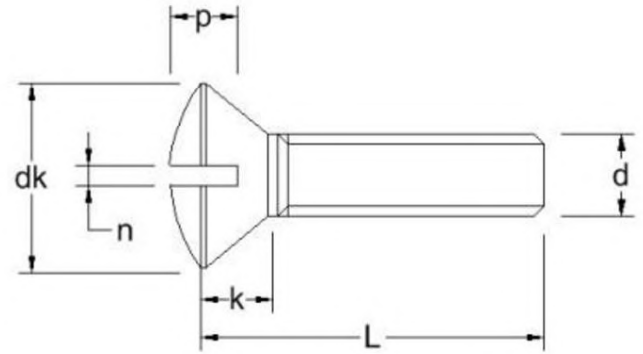

www.invayear.com

SLOT RAISED COUNTERSUNK MACHINE SCREWS ANSI B18.6.3

 Material grades: **A2**

dk	0.162	0.212	0.237	0.262	0.312	0.362	0.362	0.477										
k (Max)	0.080	0.104	0.116	0.128	0.152	0.176	0.176	0.232										
n (Max)	0.031	0.039	0.043	0.048	0.054	0.060	0.060	0.075										
p (Max)	0.045	0.059	0.067	0.074	0.088	0.103	0.103	0.136										
Length/dim	2-56	4-40	5-40	6-32	8-32	10-24	10-32	1/4-20										
3/16	■																	
1/4	■	■	■	■														
5/16	■	■	■	■	■	■	■											
3/8	■	■	■	■	■	■	■	■										
7/16	■	■	■	■	■	■	■	■										
1/2	■	■	■	■	■	■	■	■										
5/8	■	■	■	■	■	■	■	■	■									
3/4	■	■	■	■	■	■	■	■	■									
7/8		■	■	■	■	■	■	■	■									
1	■	■	■	■	■	■	■	■	■									
1.1/4		■	■	■	■	■	■	■	■									
1.1/2		■	■	■	■	■	■	■	■									
1.3/4				■	■	■	■	■	■									
2				■	■	■	■	■	■									
2.1/2						■	■	■	■									
3								■	■									

[CLICK HERE TO RETURN TO THE CONTENTS PAGE](#)



+ 37 064 411 786



Inquiry@invayear.com



www.invayear.com

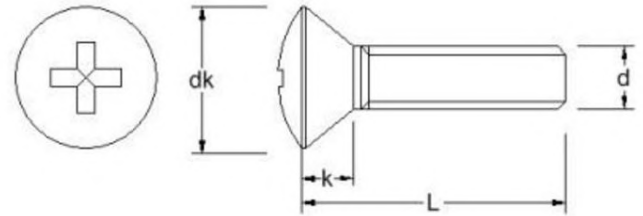

Material grades: A2: ■ A4: ◆

Drive	#1	#1		#2	#2	#2	#2	#3	#3									
dk (Max)	0.162	0.212		0.262	0.312	0.362	0.362	0.477	0.477									
k (Max)	0.080	0.104		0.128	0.152	0.176	0.176	0.232	0.232									
Length/dim	2-56	4-40	5-40	6-32	8-32	10-24	10-32	1/4-20	1/4-28									
3/16	■																	
1/4	■	◆	■	◆														
5/16	■	◆	■	◆	◆	◆	◆											
3/8	■	◆	■	◆	◆	◆	◆	◆	■	■								
7/16	■	◆	■	◆	◆	◆	◆	◆	◆	■								
1/2	■	◆	■	◆	◆	◆	◆	◆	◆	■								
5/8	■	◆	■	◆	◆	◆	◆	◆	◆	■								
3/4	■	◆	■	◆	◆	◆	◆	◆	◆	■								
7/8		◆	■	◆	◆	◆	◆	◆	◆	■								
1	■	◆	■	◆	◆	◆	◆	◆	◆	■								
1.1/4		◆	■	◆	◆	◆	◆	◆	◆									
1.1/2		◆	■	◆	◆	◆	◆	◆	◆									
1.3/4				◆	◆	◆	◆	◆	◆									
2				◆	◆	◆	◆	◆	◆									
2.1/2						◆	◆	◆	◆									
3								◆	◆									

[CLICK HERE TO RETURN TO THE CONTENTS PAGE](#)



+ 37 064 411 786



Inquiry@invayear.com

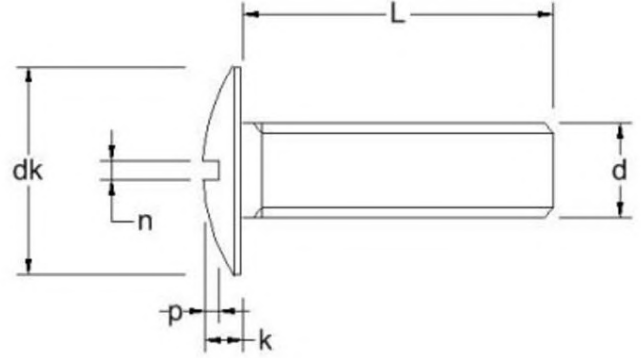

www.invayear.com

SLOT MUSHROOM MACHINE SCREWS ANSI B18.6.3

 Material grades: **A2**: ■

dk (Max)	0.321	0.384	0.448	0.448	0.573	0.573	0.698	0.823									
k (Max)	0.086	0.102	0.128	0.128	0.150	0.150	0.183	0.215									
n (Max)	0.048	0.054	0.060	0.060	0.075	0.075	0.084	0.094									
p (Max)	0.050	0.058	0.068	0.068	0.087	0.087	0.106	0.124									
Length/dim	6-32	8-32	10-24	10-32	1/4-20	1/4-28	5/16-18	3/8-16									
1/4	■	■	■	■													
5/16	■	■	■	■													
3/8	■	■	■	■	■	■											
7/16	■	■			■	■											
1/2	■	■	■	■	■	■	■	■									
5/8	■	■	■	■	■	■	■	■	■								
3/4	■	■	■	■	■	■	■	■	■								
7/8	■	■	■	■	■	■	■	■	■								
1	■	■	■	■	■	■	■	■	■								
1.1/4		■	■	■	■	■	■	■	■								
1.1/2		■	■	■	■	■	■	■	■								
1.3/4			■	■	■	■	■	■	■								
2			■	■	■	■	■	■	■								
2.1/2					■	■	■	■	■								
3					■	■	■	■	■								

[CLICK HERE TO RETURN TO THE CONTENTS PAGE](#)

+ 37 064 411 786

Inquiry@invayear.com

www.invayear.com

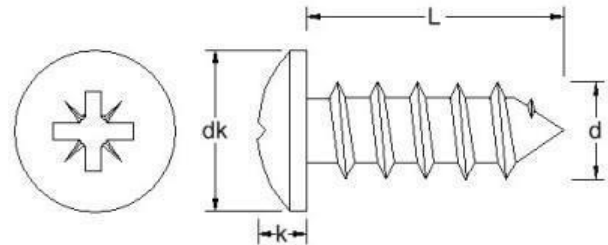
DIN 7981C Z
POZI PAN AB SELF TAPPING SCREWS DIN 7981C Z

Material grades: A2: ■ A4: ◆

dk (Max)	4.2	5.6	6.9	7.5	8.2	9.5	10.8	12.5									
k (Max)	1.8	2.2	2.6	2.8	3.05	3.55	3.95	4.55									
Length/dim	NO.2	NO.4	NO.6	NO.7	NO.8	NO.10	NO.12	NO.14									
3/16	■	■															
1/4	◆	◆	◆	◆													
5/16	■	■	◆														
3/8	◆	◆	◆	◆	◆	◆											
1/2	◆	◆	◆	◆	◆	◆	◆	◆									
5/8	◆	◆	◆	◆	◆	◆	◆	◆	◆								
3/4	◆	◆	◆	◆	◆	◆	◆	◆	◆								
7/8	◆	◆	◆	◆	◆	◆	◆	◆	◆								
1	◆	◆	◆	◆	◆	◆	◆	◆	◆								
1.1/4	■	◆	◆	◆	◆	◆	◆	◆	◆								
1.1/2			◆	◆	◆	◆	◆	◆	◆								
1.3/4			◆	◆	◆	◆	◆	◆	◆								
2			◆	◆	◆	◆	◆	◆	◆								
2.1/2			■	◆	◆	◆	◆	◆	◆								
2.3/4				◆	◆	◆	◆	◆	◆								
3				◆	◆	◆	◆	◆	◆								
3.1/2							◆	◆	◆								

CLICK HERE TO RETURN TO THE CONTENTS PAGE



+ 37 064 411 786



Inquiry@invayear.com

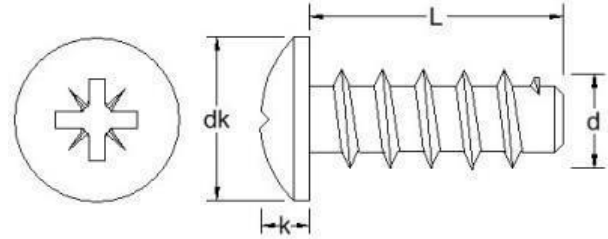

www.invayear.com

POZI PAN B SELF TAPPING SCREWS DIN 7981F Z

Material grades: A2:■

dk (Max)	4.2	5.6	6.9	7.5	8.2	9.5	10.8											
k (Max)	1.8	2.2	2.6	2.8	3.05	3.55	3.95											
Length/dim	NO.2	NO.4	NO.6	NO.7	NO.8	NO.10	NO.12											
3/16	■																	
1/4	■	■	■															
5/16	■	■	■															
3/8	■	■	■	■	■													
1/2	■	■	■		■	■												
5/8		■		■	■	■												
3/4		■		■	■	■												
7/8					■	■												
1				■		■	■											

[CLICK HERE TO RETURN TO THE CONTENTS PAGE](#)

+ 37 064 411 786

Inquiry@invayear.com

www.invayear.com

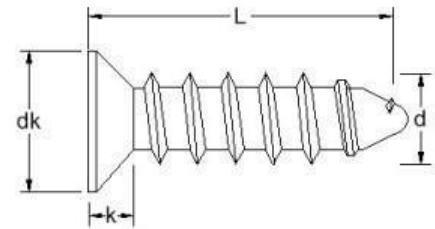
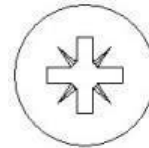
DIN 7982C Z
POZI COUNTERSUNK AB SELF TAPPING SCREWS DIN 7982C Z

Material grades: A2: ■ A4: ◆

dk (Max)	4.3	5.5	6.8	7.5	8.1	9.5	10.8	12.4									
k (Max)	1.3	1.7	2.1	2.3	2.5	3	3.4	3.8									
Length/dim	NO.2	NO.4	NO.6	NO.7	NO.8	NO.10	NO.12	NO.14									
3/16	■◆																
1/4	■◆	■◆	■◆														
5/16	■◆	■◆	■◆														
3/8	■◆	■◆	■◆	■◆	■◆	■◆											
1/2	■◆	■◆	■◆	■◆	■◆	■◆	■◆	■◆									
5/8	■◆	■◆	■◆	■◆	■◆	■◆	■◆	■◆	■◆								
3/4	■◆	■◆	■◆	■◆	■◆	■◆	■◆	■◆	■◆								
7/8	■◆	■◆	■◆	■◆	■◆	■◆	■◆	■◆	■◆								
1	■◆	■◆	■◆	■◆	■◆	■◆	■◆	■◆	■◆								
1.1/4		■◆	■◆	■◆	■◆	■◆	■◆	■◆	■◆								
1.1/2		■◆	■◆	■◆	■◆	■◆	■◆	■◆	■◆								
1.3/4			■◆	■◆	■◆	■◆	■◆	■◆	■◆								
2			■◆	■◆	■◆	■◆	■◆	■◆	■◆								
2.1/2			■	■◆	■◆	■◆	■◆	■◆	■◆								
2.3/4				■◆	■◆	■◆	■◆	■◆	■◆								
3				■	■	■◆	■◆	■◆	■◆								
3.1/2						■◆	■◆	■◆	■◆								

CLICK HERE TO RETURN TO THE CONTENTS PAGE



+ 37 064 411 786



Inquiry@invayear.com

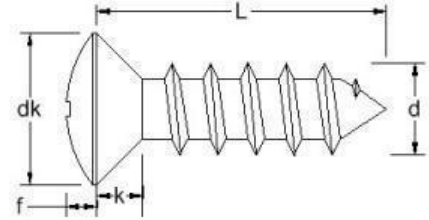
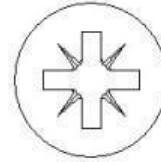

www.invayear.com

POZI RAISED COUNTERSUNK AB SELF TAPPING SCREWS DIN 7983C Z

Material grades: A2: ■ A4: ◆

dk (Max)	4.3	5.5	6.8	7.5	8.1	9.5	10.8	12.4									
f	0.7	0.9	1.2	1.3	1.4	1.5	1.7	2									
k	1.3	1.7	2.1	2.3	2.5	3	3.4	3.8									
Length/dim	NO.2	NO.4	NO.6	NO.7	NO.8	NO.10	NO.12	NO.14									
1/4	◆	◆	◆	◆													
3/8	◆	◆	◆	◆	◆	■											
1/2	◆	◆	◆	◆	◆	◆	◆	◆									
5/8	◆	◆	◆	◆	◆	◆	◆	◆									
3/4	◆	◆	◆	◆	◆	◆	◆	◆									
7/8	◆	◆	◆	◆	◆	◆	◆	◆									
1	◆	◆	◆	◆	◆	◆	◆	◆									
1.1/4	◆	◆	◆	◆	◆	◆	◆	◆									
1.1/2			◆	◆	◆	◆	◆	◆									
1.3/4			■	◆	◆	◆	◆	◆									
2			■	◆	◆	◆	◆	◆									
2.1/2					◆	◆	◆	◆									
2.3/4					◆	◆	◆	◆									
3						◆	◆	◆									
3.1/2						◆	◆	◆									
4						■	■	◆									

CLICK HERE TO RETURN TO THE CONTENTS PAGE



+ 37 064 411 786



Inquiry@invayear.com

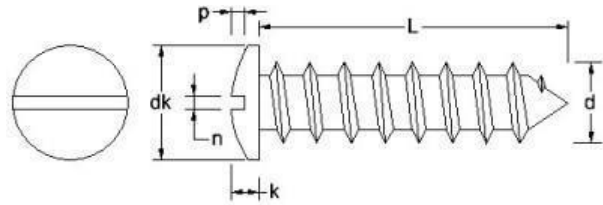

www.invayear.com

DIN 7971C
SLOT PAN AB SELF TAPPING SCREWS DIN 7971C

Material grades: A2: ■

dk (Max)	4.2	5.6	6.9	7.5	8.2	9.5	10.8	12.5										
k (Max)	1.35	1.75	2.1	2.25	2.45	2.8	3.2	3.65										
n	0.6	0.8	1	1	1.2	1.2	1.6	1.6										
p (Max)	0.8	1	1.25	1.4	1.5	1.7	1.95	2.2										
Length/dim	NO.2	NO.4	NO.6	NO.7	NO.8	NO.10	NO.12	NO.14										
1/4	■	■	■	■	■													
5/16			■															
3/8	■	■	■	■	■	■												
1/2	■	■	■	■	■	■	■	■										
5/8	■	■	■	■	■	■	■	■	■									
3/4	■	■	■	■	■	■	■	■	■									
7/8	■	■	■	■	■	■	■	■	■									
1	■	■	■	■	■	■	■	■	■									
1.1/4		■	■	■	■	■	■	■	■									
1.1/2			■	■	■	■	■	■	■									
1.3/4					■	■	■	■	■									
2				■	■	■	■	■	■									
2.1/2						■	■	■	■									
2.3/4						■	■	■	■									
3						■	■											
4						■												

[CLICK HERE TO RETURN TO THE CONTENTS PAGE](#)

+ 37 064 411 786

Inquiry@invayear.com

www.invayear.com

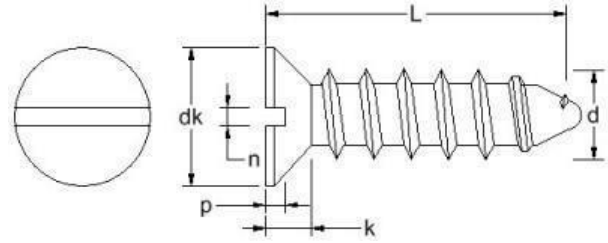
SLOT COUNTERSUNK AB SELF TAPPING SCREWS DIN 7972C

Material grades: A2: ■

dk (Max)	4.3	5.5	6.8	7.5	8.1	9.5	10.8	12.4										
k	1.3	1.7	2.1	2.3	2.5	3	3.4	3.8										
n	0.6	0.8	1	1	1.2	1.2	1.6	1.6										
p (Max)	0.6	0.75	0.95	1.05	1.15	1.35	1.5	1.75										
Length/dim	NO.2	NO.4	NO.6	NO.7	NO.8	NO.10	NO.12	NO.14										
1/4	■	■	■															
3/8	■	■	■	■	■													
1/2	■	■	■	■	■	■	■	■										
5/8	■	■	■	■	■	■	■	■										
3/4	■	■	■	■	■	■	■	■										
7/8	■	■	■	■	■	■	■	■										
1	■	■	■	■	■	■	■	■										
1.1/4			■	■	■	■	■	■										
1.1/2			■	■	■	■	■	■										
1.3/4				■	■	■	■	■										
2					■	■	■	■										
2.1/2						■	■	■										
2.3/4						■	■	■										
3						■	■	■										

CLICK HERE TO RETURN TO THE CONTENTS PAGE



+ 37 064 411 786



Inquiry@invayear.com

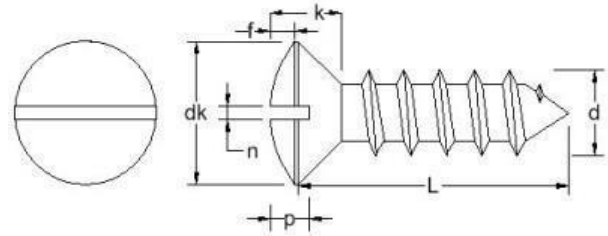

www.invayear.com

DIN 7973C
SLOT RAISED COUNTERSUNK AB SELF TAPPING SCREWS DIN 7973C

 Material grades: **A2**

dk (Max)	4.3	5.5	6.8	7.5	8.1	9.5	10.8	12.4									
f	*	0.9	1.2	1.3	1.4	*	*	*									
k	1.3	1.7	2.1	2.3	2.5	3	3.4	3.8									
n	0.6	0.8	1	1	1.2	1.2	1.6	1.6									
p (Max)	1.15	1.5	1.9	2.05	2.25	2.6	2.95	3.45									
Length/dim	NO.2	NO.4	NO.6	NO.7	NO.8	NO.10	NO.12	NO.14									
1/4	■	■	■														
3/8	■	■	■	■	■	■											
1/2	■	■	■	■	■	■	■	■									
5/8	■	■	■	■	■	■	■	■									
3/4	■	■	■	■	■	■	■	■									
7/8	■	■	■	■	■	■	■	■									
1	■	■	■	■	■	■	■	■									
1.1/4		■	■	■	■	■	■	■									
1.1/2			■	■	■	■	■	■									
1.3/4			■	■	■	■	■	■									
2					■	■	■	■									
2.1/2						■	■										
2.3/4						■											

[CLICK HERE TO RETURN TO THE CONTENTS PAGE](#)



+ 37 064 411 786

Inquiry@invayear.com

www.invayear.com

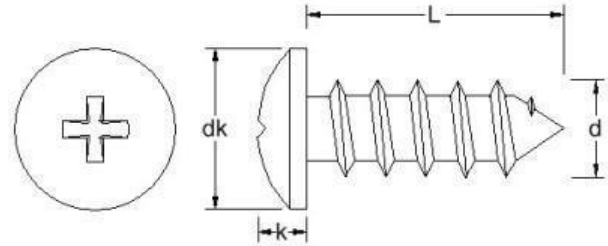
PHILLIPS PAN AB SELF TAPPING SCREWS DIN 7981C H

Material grades: A2: ■ A4: ◆

dk (Max)	4.2	5.6	6.9	7.5	8.2	9.5	10.8	12.5										
k (Max)	1.8	2.2	2.6	2.8	3.05	3.55	3.95	4.55										
Length/dim	NO.2	NO.4	NO.6	NO.7	NO.8	NO.10	NO.12	NO.14										
3/16	■◆																	
1/4	■◆	■◆	■◆	■◆	■◆													
3/8	■◆	■◆	■◆	■◆	■◆	■◆	■											
1/2	■◆	■◆	■◆	■◆	■◆	■◆	■◆	■◆										
5/8	■◆	■◆	■◆	■◆	■◆	■◆	■◆	■◆										
3/4	■◆	■◆	■◆	■◆	■◆	■◆	■◆	■◆										
7/8	■◆	■◆	■◆	■◆	■◆	■◆	■◆	■◆										
1	■◆	■◆	■◆	■◆	■◆	■◆	■◆	■◆										
1.1/4	■◆	■◆	■◆	■◆	■◆	■◆	■◆	■◆										
1.1/2		■◆	■◆	■◆	■◆	■◆	■◆	■◆										
1.3/4			■◆	■◆	■◆	■◆	■◆	■◆										
2			■◆	■◆	■◆	■◆	■◆	■◆										
2.1/4					■	■	■											
2.1/2			■◆	■◆	■◆	■◆	■◆	■◆										
2.3/4			■◆	■◆	■◆	■◆	■◆	■◆										
3				■◆	■◆	■◆	■◆	■◆										
3.1/2					■	■◆	■◆	■◆										
4					■	■◆	■◆	■◆										
5						■	■											

[CLICK HERE TO RETURN TO THE CONTENTS PAGE](#)

+ 37 064 411 786

Inquiry@invayear.com

www.invayear.com

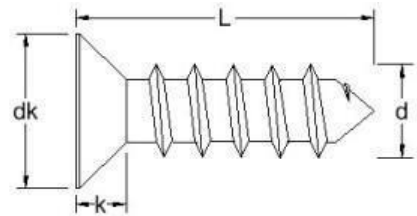
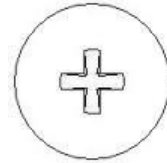
DIN 7982C H
PHILLIPS COUNTERSUNK AB SELF TAPPING SCREWS DIN 7982C H

Material grades: A2: ■ A4: ◆

dk (Max)	4.3	5.5	6.8	7.5	8.1	9.5	10.8	12.4									
k (Max)	1.3	1.7	2.1	2.3	2.5	3	3.4	3.8									
Length/dim	NO.2	NO.4	NO.6	NO.7	NO.8	NO.10	NO.12	NO.14									
1/4	◆	◆	◆	◆													
3/8	◆	◆	◆	◆	◆	◆											
1/2	◆	◆	◆	◆	◆	◆	◆	◆									
5/8	◆	◆	◆	◆	◆	◆	◆	◆									
3/4	◆	◆	◆	◆	◆	◆	◆	◆									
7/8	◆	◆	◆	◆	◆	◆	◆	◆									
1	◆	◆	◆	◆	◆	◆	◆	◆									
1.1/4	◆	◆	◆	◆	◆	◆	◆	◆									
1.1/2		◆	◆	◆	◆	◆	◆	◆									
1.3/4			◆	◆	◆	◆	◆	◆									
2			◆	◆	◆	◆	◆	◆									
2.1/4				◆		◆	◆										
2.1/2			◆	◆	◆	◆	◆	◆									
2.3/4			◆	◆	◆	◆	◆	◆									
3				◆	◆	◆	◆	◆									
3.1/2					◆	◆	◆	◆									
4					◆	◆	◆	◆									
5						◆	◆										

[CLICK HERE TO RETURN TO THE CONTENTS PAGE](#)



+ 37 064 411 786



Inquiry@invayear.com

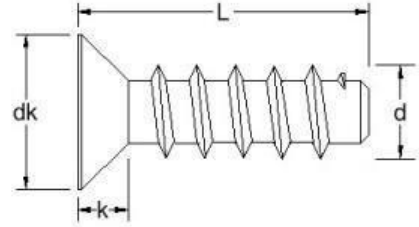
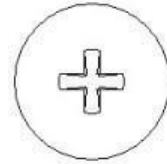

www.invayear.com

PHILLIPS COUNTERSUNK B SELF TAPPING SCREWS DIN 7982F H

Material grades: A2: ■

dk (Max)	5.5	6.8	7.5	8.1	9.5	10.8										
k (Max)	1.7	2.1	2.3	2.5	3	3.4										
Length/dim	NO.4	NO.6	NO.7	NO.8	NO.10	NO.12										
3/8	■															
1/2	■	■		■	■											
5/8	■	■	■	■	■	■										
3/4		■	■	■	■	■										
7/8		■	■		■	■										
1		■	■	■	■	■										
1.1/4			■	■	■											

[CLICK HERE TO RETURN TO THE CONTENTS PAGE](#)



+ 37 064 411 786



Inquiry@invayear.com

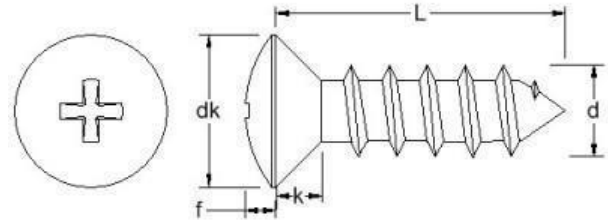

www.invayear.com

DIN 7983C H
PHILLIPS RAISED COUNTERSUNK AB SELF TAPPING SCREWS DIN 7983C H

Material grades: A2: ■ A4: ◆

dk (Max)	4.3	5.5	6.8	7.5	8.1	9.5	10.8	12.4									
f	0.7	0.9	1.2	1.3	1.4	1.5	1.7	2									
k	1.3	1.7	2.1	2.3	2.5	3	3.4	3.8									
Length/dim	NO.2	NO.4	NO.6	NO.7	NO.8	NO.10	NO.12	NO.14									
1/4	■◆	■◆	■														
3/8	■◆	■◆	■◆		■◆	■											
1/2	■◆	■◆	■◆	■◆	■◆	■◆	■◆	■◆									
5/8	■◆	■◆	■◆	■◆	■◆	■◆	■◆	■◆									
3/4	■◆	■◆	■◆	■◆	■◆	■◆	■◆	■◆									
7/8	■◆	■◆	■◆	■◆	■◆	■◆	■◆	■◆									
1	■◆	■◆	■◆	■◆	■◆	■◆	■◆	■◆									
1.1/4	■	■◆	■◆	■◆	■◆	■◆	■◆	■◆									
1.1/2		■	■◆	■◆	■◆	■◆	■◆	■◆									
1.3/4			■◆	■◆	■◆	■◆	■◆	■◆									
2			■◆	■◆	■◆	■◆	■◆	■◆									
2.1/2				■	■◆	■◆	■◆	■◆									
2.3/4				■	■◆	■◆	■◆	■◆									
3					■	■◆	■◆	■◆									
3.1/2						■◆	■◆	■◆									
4						■◆	■◆	◆									
5								■									

[CLICK HERE TO RETURN TO THE CONTENTS PAGE](#)



+ 37 064 411 786



Inquiry@invayear.com

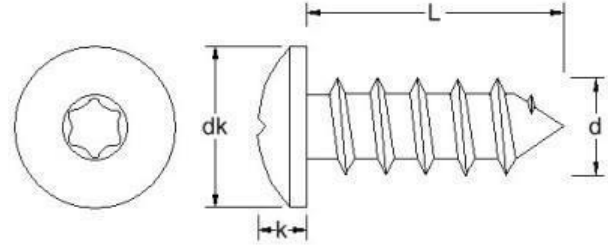

www.invayear.com

TX PAN AB SELF TAPPING SCREWS DIN 7981C TX

Material grades: A2: ■ A4: ◆

dk (Max)	4.2	5.6	6.9	7.5	8.2	9.5	10.8	12.5									
k (Max)	1.8	2.2	2.6	2.8	3.05	3.55	3.95	4.55									
Length/dim	NO.2	NO.4	NO.6	NO.7	NO.8	NO.10	NO.12	NO.14									
1/4	■◆	■◆	■◆	■													
3/8	■◆	■◆	■◆	■◆	■◆	■											
1/2	■◆	■◆	■◆	■◆	■◆	■◆	■◆	■◆									
5/8	■◆	■◆	■◆	■◆	■◆	■◆	■◆	■◆									
3/4	■◆	■◆	■◆	■◆	■◆	■◆	■◆	■◆									
7/8	■◆	■◆	■◆	■◆	■◆	■◆	■◆	■◆	■								
1	■◆	■◆	■◆	■◆	■◆	■◆	■◆	■◆	■◆								
1.1/4		■◆	■◆	■◆	■◆	■◆	■◆	■◆	■◆								
1.1/2			■◆	■◆	■◆	■◆	■◆	■◆	■◆								
1.3/4			■◆	■◆	■◆	■◆	■◆	■◆	■◆								
2			■◆	■◆	■◆	■◆	■◆	■◆	■◆								
2.1/2				■◆	■◆	■◆	■◆	■◆	■◆								
2.3/4						■◆	■◆	■◆	■◆								
3							◆	■◆	■◆								

CLICK HERE TO RETURN TO THE CONTENTS PAGE



+ 37 064 411 786



Inquiry@invayear.com



www.invayear.com

DIN 7982C TX

TX COUNTERSUNK AB SELF TAPPING SCREWS DIN 7982C TX

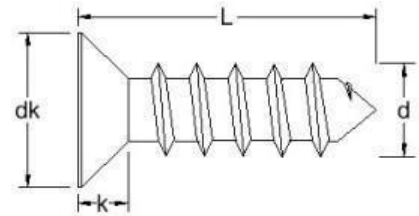
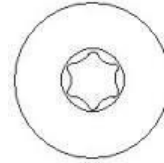

Material grades: A2: ■ A4: ◆

dk (Max)	4.3	5.5	6.8	7.5	8.1	9.5	10.8	12.4									
k (Max)	1.3	1.7	2.1	2.3	2.5	3	3.4	3.8									
Length/dim	NO.2	NO.4	NO.6	NO.7	NO.8	NO.10	NO.12	NO.14									
1/4	■◆	■◆	■◆	■													
3/8	■◆	■◆	■◆	■	■◆												
1/2	■◆	■◆	■◆	■◆	■◆	■◆	■◆	■◆									
5/8	■◆	■◆	■◆	■◆	■◆	■◆	■◆	■◆									
3/4	■◆	■◆	■◆	■◆	■◆	■◆	■◆	■◆									
7/8	■◆	■◆	■◆	■◆	■◆	■◆	■◆	■◆									
1	■◆	■◆	■◆	■◆	■◆	■◆	■◆	■◆									
1.1/4		◆	■◆	■◆	■◆	■◆	■◆	■◆									
1.1/2			■◆	■◆	■◆	■◆	■◆	■◆									
1.3/4			■◆	■◆	■◆	■◆	■◆	■◆									
2			■◆	■◆	■◆	■◆	■◆	■◆									
2.1/2				■◆	■◆	■◆	■◆	■◆									
2.3/4							■◆	■◆									
3					◆		■◆	■◆									

[CLICK HERE TO RETURN TO THE CONTENTS PAGE](#)



+ 37 064 411 786



Inquiry@invayear.com

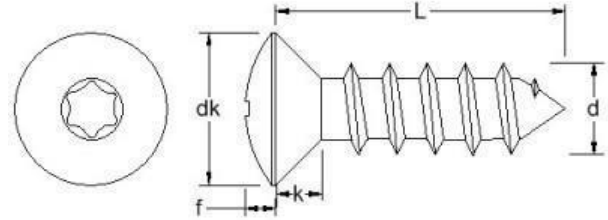

www.invayear.com

TX RAISED COUNTERSUNK AB SELF TAPPING SCREWS DIN 7983C TX

Material grades: A2: ■ A4: ◆

dk (Max)	*	5.5	6.8	7.5	8.1	9.5	10.8	12.4										
f (Max)	*	0.9	1.2	1.3	1.4	1.5	1.7	2										
k (Max)	*	1.7	2.1	2.3	2.5	3	3.4	3.8										
Length/dim	NO.2	NO.4	NO.6	NO.7	NO.8	NO.10	NO.12	NO.14										
1/4	◆	◆	◆	◆														
3/8	◆	◆	◆	◆	◆	◆												
1/2	◆	◆	◆	◆	◆	◆	◆	◆										
5/8	◆	◆	◆	◆	◆	◆	◆	◆	◆									
3/4	◆	◆	◆	◆	◆	◆	◆	◆	◆									
7/8	◆	■	◆	◆	◆	◆	◆	◆	◆									
1	◆	◆	◆	◆	◆	◆	◆	◆	◆									
1.1/4		◆	◆	◆	◆	◆	◆	◆	◆									
1.1/2			◆	◆	◆	◆	◆	◆	◆									
1.3/4			◆	◆	◆	◆	◆	◆	◆									
2			◆	◆	◆	◆	◆	◆	◆									
2.1/2					◆	◆	◆	◆	◆									
2.3/4						◆	◆	◆	◆									
3						◆	◆	◆	◆									

CLICK HERE TO RETURN TO THE CONTENTS PAGE



+ 37 064 411 786



Inquiry@invayear.com



www.invayear.com

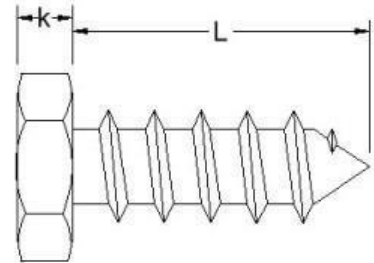
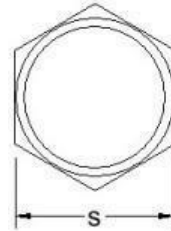

Material grades: A2: ■

k (Max)	*	2.42	2.42	2.92	3.12	4.15	4.95	5.95								
s	*	5.5	7	7	8	8	10	13								
Length/dim	NO.4	NO.6	NO.7	NO.8	NO.10	NO.12	NO.14	NO.16								
3/8	■	■	■	■	■											
1/2	■	■	■	■	■	■	■									
5/8	■	■	■	■	■	■	■	■								
3/4	■	■	■	■	■	■	■	■								
7/8	■	■	■	■	■	■	■	■								
1	■	■	■	■	■	■	■	■								
1.1/4	■	■	■	■	■	■	■	■								
1.1/2	■	■	■	■	■	■	■	■								
1.3/4	■	■	■	■	■	■	■	■								
2		■	■	■	■	■	■	■								
2.1/4					■		■									
2.1/2			■	■	■	■	■	■								
2.3/4				■	■	■	■	■								
3					■	■	■									
3.1/2					■	■	■									
4					■	■	■									
4.1/2					■	■	■									
5					■	■	■									

CLICK HERE TO RETURN TO THE CONTENTS PAGE



+ 37 064 411 786



Inquiry@invayear.com

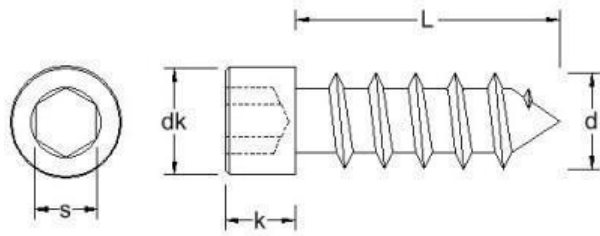

www.invayear.com

SOCKET CAP HEAD SELF TAPPING SCREWS

Material grades: A2: ■ A4: ◆

dk (Max)	8.5	10	10																
k (Max)	5	6	6																
s	4	5	5																
Length/dim	NO.10	NO.12	NO.14																
3/8	■ ◆	■ ◆	■ ◆																
1/2	■ ◆	■ ◆	■ ◆																
5/8	■ ◆	■ ◆	■ ◆																
3/4	■ ◆	■ ◆	■ ◆																
7/8	■ ◆	■ ◆	■ ◆																
1	■ ◆	■ ◆	■ ◆																
1.1/4	■ ◆	■ ◆	■ ◆																
1.1/2	■ ◆	■ ◆	■ ◆																
1.5/8		■ ◆																	
1.3/4	■ ◆	■ ◆	■ ◆																
2	■ ◆	■ ◆	■ ◆																
2.1/4	■ ◆	■ ◆	■ ◆																
2.1/2	■ ◆	■ ◆	■ ◆																
2.3/4	■ ◆	■ ◆	■ ◆																

CLICK HERE TO RETURN TO THE CONTENTS PAGE



+ 37 064 411 786



Inquiry@invayear.com



www.invayear.com

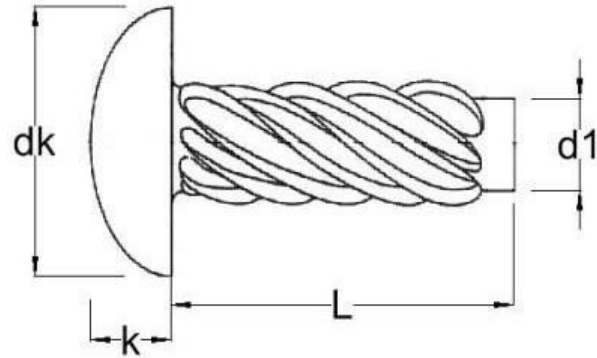

Material grades: A2: ■

d1 (Max)	0.049	0.063	0.083	0.096	0.116	0.136	0.150	0.177	0.202								
dk (Max)	0.099	0.127	0.162	0.211	0.260	0.309	0.359	0.408	0.457								
k (Max)	0.034	0.049	0.069	0.086	0.103	0.120	0.137	0.153	0.170								
Length/dim	NO.00	NO.0	NO.2	NO.4	NO.6	NO.8	NO.10	NO.12	NO.14								
1/8	■	■	■														
3/16	■	■	■	■													
1/4	■	■	■	■	■	■											
5/16	■	■	■	■	■	■											
3/8	■	■	■	■	■	■	■										
1/2			■		■	■	■	■	■								
5/8					■												
3/4					■												

CLICK HERE TO RETURN TO THE CONTENTS PAGE



+ 37 064 411 786



Inquiry@invayear.com

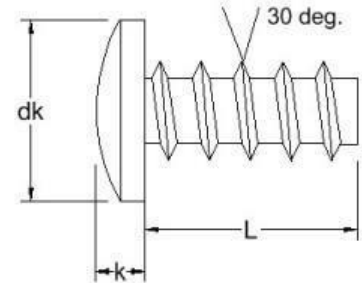
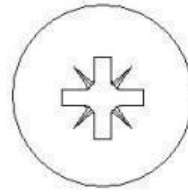

www.invayear.com

POZI PAN POLYTECH 30

Material grades: A2:■

Drive	#1	#1	#2	#2															
dk (Max)	3.9	5.3	6.1	7.0															
k (Max)	1.5	2.0	2.5	2.7															
Length/dim	2.5	3.0	3.5	4.0															
6	■	■																	
8	■	■	■	■															
10		■	■	■															
12		■	■	■															
14		■	■	■															
16		■	■	■															
18		■	■	■															
20		■	■	■															
25			■	■															

[CLICK HERE TO RETURN TO THE CONTENTS PAGE](#)



+ 37 064 411 786



Inquiry@invayear.com



www.invayear.com

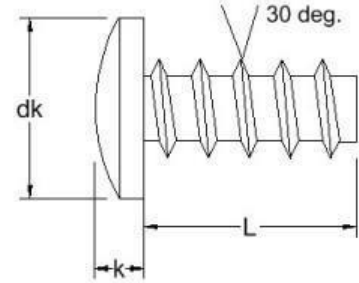
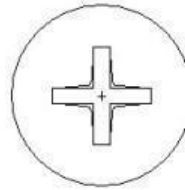

Material grades: A2:■

Drive	#1	#2	#2															
dk (Max)	5.3	6.0	7.14															
k (Max)	2.2	2.55	2.7															
Length/dim	3.0	3.5	4.0															
8	■	■	■															
10	■	■	■															
12	■	■	■															
14	■	■	■															
16	■	■	■															
20	■	■	■															
25	■	■	■															

[CLICK HERE TO RETURN TO THE CONTENTS PAGE](#)



+ 37 064 411 786

Inquiry@invayear.com

www.invayear.com

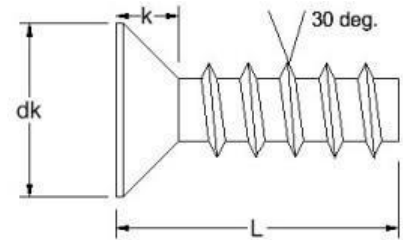
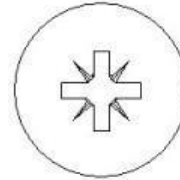
POZI COUNTERSUNK POLYTECH 30

Material grades: A2:■

Drive	#1	#2	#2															
dk (Max)	5.5	7.3	8.4															
k (Max)	2.05	2.8	3.25															
Length/dim	3.0	3.5	4.0															
8	■	■																
10	■	■	■															
12	■	■	■															
14		■	■															
16		■	■															

[CLICK HERE TO RETURN TO THE CONTENTS PAGE](#)

+ 37 064 411 786

Inquiry@invayear.com

www.invayear.com

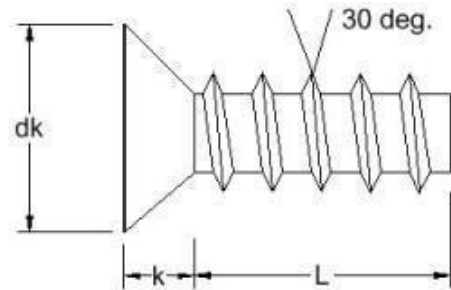
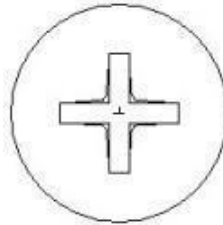

Material grades: A2: ■

Drive	#1	#2	#2																
dk (Max)	5.2	6.7	7.7																
k (Max)	2.2	2.55	2.7																
Length/dim	3.0	3.5	4.0																
8	■	■	■																
10	■	■	■																
12	■	■	■																
14	■	■	■																
16	■	■	■																

CLICK HERE TO RETURN TO THE CONTENTS PAGE



+ 37 064 411 786



Inquiry@invayear.com

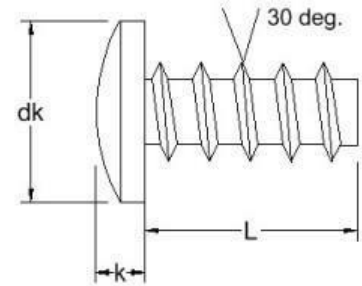
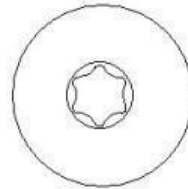

www.invayear.com

TX PAN POLYTECH 30

Material grades: A2: ■

Drive	TX7	TX10	TX10	TX20	TX20														
dk (Max)	4.2	5.6	6.9	7.5	8.2														
k (Max)	1.6	2.1	2.3	2.6	2.9														
Length/dim	2.5	3.0	3.5	4.0	5.0														
6	■	■																	
8	■	■	■	■															
10		■	■	■	■														
12		■	■	■	■														
14		■	■	■															
16		■	■	■	■														
18		■	■	■															
20		■	■	■	■														
25				■	■														
30					■														

[CLICK HERE TO RETURN TO THE CONTENTS PAGE](#)



+ 37 064 411 786



Inquiry@invayear.com

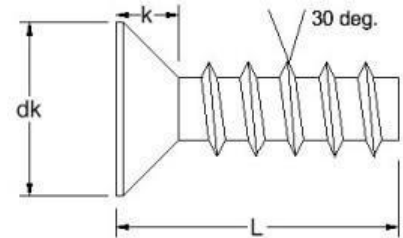
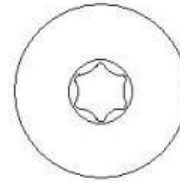

www.invayear.com

 Material grades: **A2**

Drive	TX10	TX10	TX20	TX20													
dk (Max)	5.5	7.3	8.4	9.3													
k (Max)	2.05	2.80	3.25	3.40													
Length/dim	3.0	3.5	4.0	5.0													
6	■																
8	■	■															
10	■	■	■	■													
12	■	■	■	■													
16	■	■	■	■													
20			■	■													
25				■													

CLICK HERE TO RETURN TO THE CONTENTS PAGE



+ 37 064 411 786



Inquiry@invayear.com

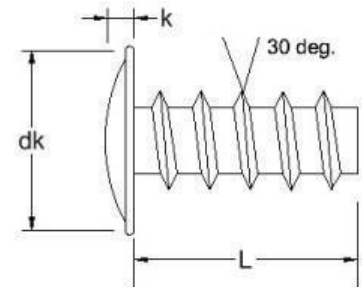
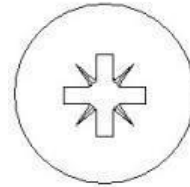

www.invayear.com

POZI FLANGED POLYTECH 30

Material grades: A2: ■

Drive	#1	#2	#2															
dk (Max)	6.0	7.0	8.0															
k (Max)	2.1	2.4	2.5															
Length/dim	3.0	3.5	4.0															
8	■																	
10	■	■	■															
12	■	■	■															
14	■	■	■															
16		■	■															

[CLICK HERE TO RETURN TO THE CONTENTS PAGE](#)



+ 37 064 411 786



Inquiry@invayear.com



www.invayear.com

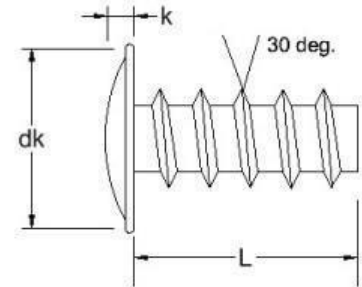
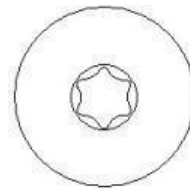

Material grades: A2:■

Drive	T10	T10	T20	T20														
dk (Max)	6.0	7.0	8.0	10														
k (Max)	2.1	2.4	2.5	3.2														
Length/dim	3.0	3.5	4.0	5.0														
8	■																	
10	■	■	■															
12	■	■	■	■														
14	■	■	■	■														
16		■	■	■														

[CLICK HERE TO RETURN TO THE CONTENTS PAGE](#)



+ 37 064 411 786

Inquiry@invayear.com

www.invayear.com

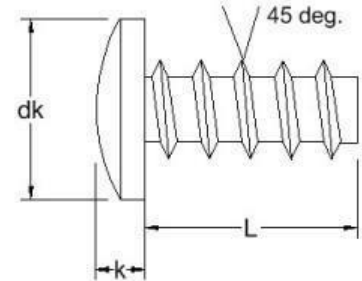
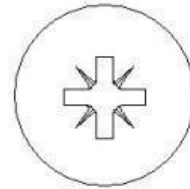
POZI PAN POLYFIX 45

Material grades: A2:■

Drive	#1	#1	#1	#2														
dk (Max)	4.0	5.0	6.0	7.0														
k (Max)	1.6	1.95	2.3	2.45														
Length/dim	2.5	3.0	3.5	4.0														
6	■	■	■															
8	■	■	■	■														
10	■	■	■	■														
12	■	■	■	■														
16		■	■	■														
20		■	■	■														
25			■	■														

[CLICK HERE TO RETURN TO THE CONTENTS PAGE](#)



+ 37 064 411 786



Inquiry@invayear.com



www.invayear.com

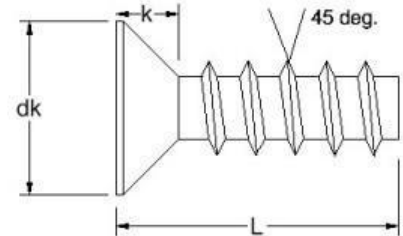
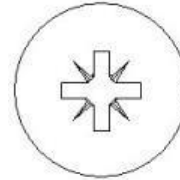

Material grades: A2:■

Drive	#1	#1	#2															
dk (Max)	5.5	6.3	7.35															
k (Max)	1.60	1.65	1.90															
Length/dim	3.0	3.5	4.0															
6		■																
8	■	■	■															
10	■	■	■															
12	■	■	■															
16	■	■	■															
20	■	■	■															

[CLICK HERE TO RETURN TO THE CONTENTS PAGE](#)



+ 37 064 411 786



Inquiry@invayear.com

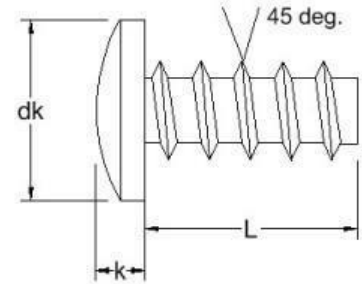
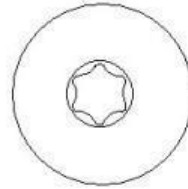

www.invayear.com

TX PAN POLYFIX 45

Material grades: A2: ■

Drive	TX8	TX10	TX15															
dk (Max)	5.0	6.0	7.0															
k (Max)	1.95	2.3	2.45															
Length/dim	3.0	3.5	4.0															
6	■	■	■															
8	■	■	■															
10	■	■	■															
12	■	■	■															
16	■	■	■															
20	■	■	■															

CLICK HERE TO RETURN TO THE CONTENTS PAGE



+ 37 064 411 786



Inquiry@invayear.com



www.invayear.com

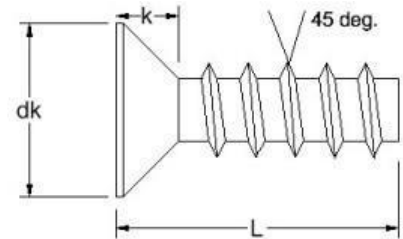
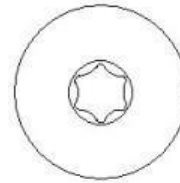

Material grades: A2: ■

Drive	TX8	TX10	TX15																
dk (Max)	5.5	6.3	7.35																
k (Max)	1.60	1.65	1.90																
Length/dim	3.0	3.5	4.0																
6	■	■																	
8	■	■	■																
10	■	■	■																
12	■	■	■																
16	■	■	■																
20	■	■	■																

CLICK HERE TO RETURN TO THE CONTENTS PAGE



+ 37 064 411 786



Inquiry@invayear.com

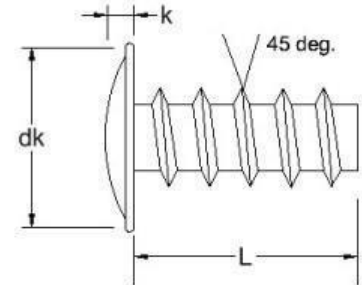
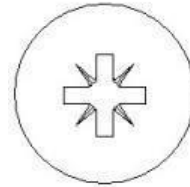

www.invayear.com

POZI FLANGED POLYFIX 45

Material grades: A2: ■

Drive	#1	#2	#2															
dk (Max)	6.0	8.0	9.6															
k (Max)	1.60	2.00	2.30															
Length/dim	3.5	4.0	5.0															
6	■																	
8	■	■																
10	■	■																
12	■	■																
16	■	■	■															
20	■	■	■															
25	■	■	■															

[CLICK HERE TO RETURN TO THE CONTENTS PAGE](#)

+ 37 064 411 786

Inquiry@invayear.com

www.invayear.com

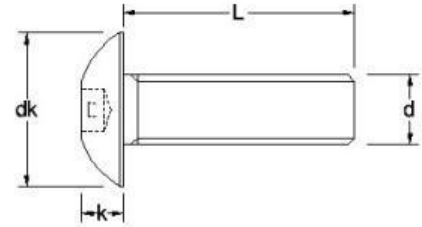
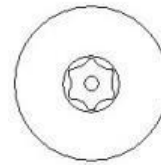
SECURITY SCREWS
PIN TX BUTTON SCREWS

Material grades: A2: ■

dk	5.5	7.4	9.3	10.4	13.7	17												
k	1.6	2.1	2.7	3.2	4.3	5.8												
Pitch	0.5	0.7	0.8	1.0	1.25	1.5												
Length/dim	M3	M4	M5	M6	M8	M10												
6	■	■																
8	■	■	■	■														
10	■	■	■	■	■													
12	■	■	■	■	■													
16	■	■	■	■	■	■												
20	■	■	■	■	■	■												
25	■	■	■	■	■	■												
30	■	■	■	■	■	■												
35		■	■		■	■												
40		■	■	■	■	■												
45		■	■															
50		■	■	■	■	■												
60		■	■	■	■	■												
65						■												
70					■	■												
75					■													
80				■	■	■												
100					■													

CLICK HERE TO RETURN TO THE CONTENTS PAGE



+ 37 064 411 786



Inquiry@invayear.com

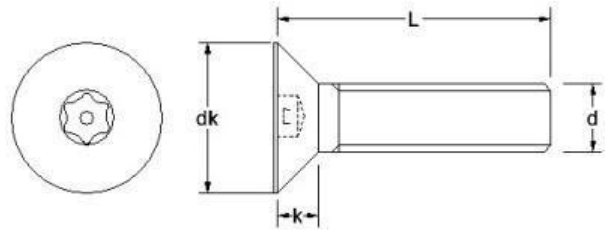

www.invayear.com

PIN TX COUNTERSUNK SCREWS

Material grades: A2: ■

dk	5.6	7.8	9.8	11.6	15.2	17.4											
k	2	2.3	2.8	3.3	5	5.1											
Pitch	0.5	0.7	0.8	1.0	1.25	1.5											
Length/dim	M3	M4	M5	M6	M8	M10											
6	■	■															
8	■	■	■	■													
10	■	■	■	■													
12	■	■	■	■													
16	■	■	■	■	■												
20	■	■	■	■	■												
25	■	■	■	■	■	■											
30		■	■	■	■												
35						■											
40		■	■	■	■	■											
50		■	■	■	■	■											
55					■												
60			■	■	■	■											
70		■		■													
80			■	■	■	■											

[CLICK HERE TO RETURN TO THE CONTENTS PAGE](#)



+ 37 064 411 786



Inquiry@invayear.com



www.invayear.com

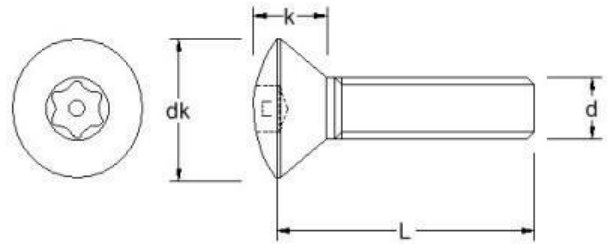

Material grades: A2: ■

dk	6.4																			
k	1.8																			
Pitch	0.60																			
Length/dim	M3.5																			
12	■																			
20	■																			
25	■																			
30	■																			
35	■																			
40	■																			
50	■																			
75	■																			

CLICK HERE TO RETURN TO THE CONTENTS PAGE



+ 37 064 411 786



Inquiry@invayear.com

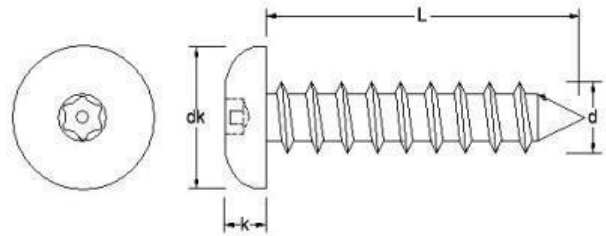

www.invayear.com

PIN TX BUTTON SELF TAPPING SCREWS

Material grades: A2: ■

dk	6.7	7.4	9.3	10.2	11													
k	2.6	2.2	2.6	3.1	3.4													
Length/dim	NO.6	NO.8	NO.10	NO.12	NO.14													
3/8	■	■																
1/2	■	■	■															
5/8	■	■	■															
3/4	■	■	■															
1	■	■	■	■	■													
1.1/4		■	■	■	■													
1.1/2	■	■	■	■	■													
2		■	■	■	■													
2.1/2				■														
3				■														

[CLICK HERE TO RETURN TO THE CONTENTS PAGE](#)

+ 37 064 411 786

Inquiry@invayear.com

www.invayear.com

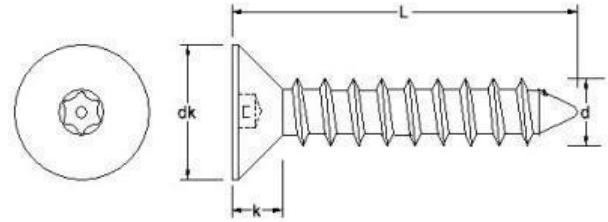

Material grades: A2:■

dk	4.9	6.6	7.9	9.3	10.6	12.4													
k	1.5	2.1	2.5	3	3.4	3.8													
Length/dim	NO.4	NO.6	NO.8	NO.10	NO.12	NO.14													
1/2	■	■	■	■															
5/8		■	■	■															
3/4	■	■	■	■															
1		■	■	■	■	■													
1.1/4		■	■	■	■	■													
1.1/2		■	■	■	■	■													
2			■	■	■	■													
2.1/2			■	■	■														
3				■	■														
4				■															

CLICK HERE TO RETURN TO THE CONTENTS PAGE



+ 37 064 411 786



Inquiry@invayear.com

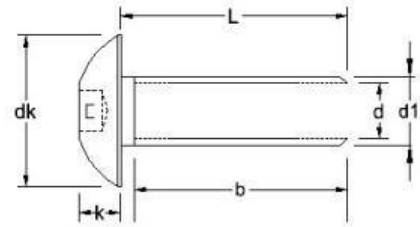
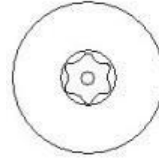

www.invayear.com

PIN TX BARREL NUTS

Material grades: A2: ■

b	6	6	9	20	12	25	14											
dI	5.2	6.3	8	8	10	10	12.5											
dk	9	10	12	12	14.3	14.3	18											
k	2.8	3.3	4.4	4.4	5	5	5.8											
L	9	10	12	25	16	30	20											
Pitch	0.7	0.8	1.0	1.0	1.25	1.25	1.5											
Length/dim	M4	M5	M6	M6	M8	M8	M10											
10	■	■																
12			■															
16					■													
20							■											
25				■														
30						■												

[CLICK HERE TO RETURN TO THE CONTENTS PAGE](#)

+ 37 064 411 786

Inquiry@invayear.com

www.invayear.com

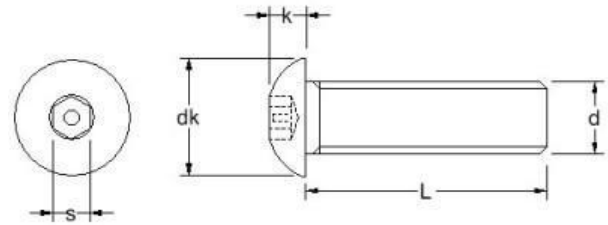

Material grades: A2: ■

dk	5.5	7.4	9.3	10.3	13.7	17.1	20.4										
k	1.5	2.2	2.7	3.2	4.4	5.6	6.5										
Pitch	0.5	0.7	0.8	1.0	1.25	1.5	1.75										
Length/dim	M3	M4	M5	M6	M8	M10	M12										
8		■															
10	■	■	■	■													
12	■	■	■	■	■												
16	■	■	■	■	■	■											
20	■	■	■	■	■	■	■										
25		■	■	■	■	■	■										
30		■	■	■	■	■	■										
35						■											
40		■	■	■	■	■	■										
50			■	■	■	■	■										
60			■	■	■	■	■										
100						■											

[CLICK HERE TO RETURN TO THE CONTENTS PAGE](#)



+ 37 064 411 786



Inquiry@invayear.com

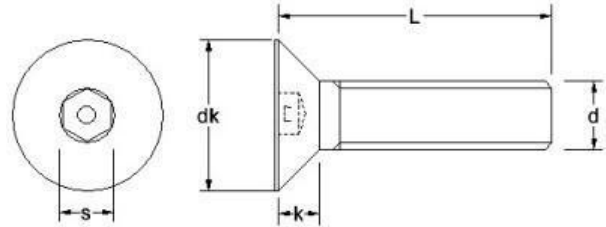

www.invayear.com

PIN HEX COUNTERSUNK SCREWS

Material grades: A2: ■

dk	5.7	7.7	9.8	11.8	15.1	19.3	23.2										
k	1.7	2.3	2.8	3.3	5	6.7	7.4										
Pitch	0.5	0.7	0.8	1.0	1.25	1.5	1.75										
Length/dim	M3	M4	M5	M6	M8	M10	M12										
8		■	■	■													
10	■	■	■	■													
12	■	■	■	■	■												
16	■	■	■	■	■												
20	■	■	■	■	■	■	■										
25		■	■	■	■	■	■										
30		■	■	■	■	■	■										
35					■												
40		■	■	■	■	■	■										
50			■	■	■	■	■										
60			■	■	■	■											

[CLICK HERE TO RETURN TO THE CONTENTS PAGE](#)

+ 37 064 411 786

Inquiry@invayear.com

www.invayear.com

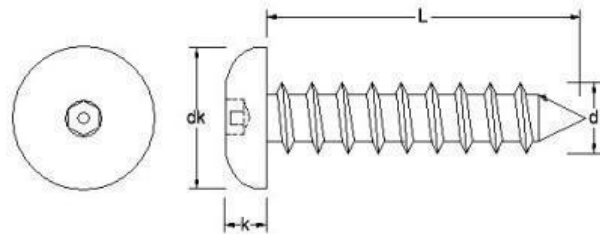
PIN HEX BUTTON SELF TAPPING SCREWS

Material grades: A2: ■

dk	6.7	7.4	9.3	10.3	11													
k	2.5	2.1	2.6	3.2	3.4													
Length/dim	NO.6	NO.8	NO.10	NO.12	NO.14													
3/8	■																	
1/2	■	■	■															
5/8	■	■	■															
3/4	■	■	■	■	■													
1	■	■	■	■	■													
1.1/4		■	■	■	■													
1.1/2	■	■	■	■	■													
2		■	■	■	■													
2.1/2			■															

[CLICK HERE TO RETURN TO THE CONTENTS PAGE](#)

+ 37 064 411 786

Inquiry@invayear.com

www.invayear.com

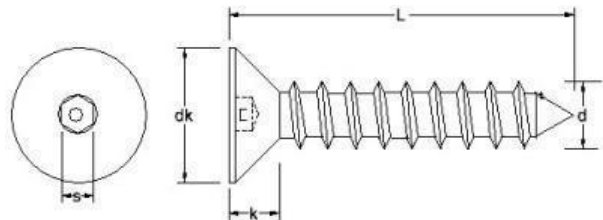

Material grades: A2:■

dk	6.6	7.9	9.3	10.4	12.4													
k	2.1	2.5	3	3.4	3.8													
Length/dim	NO.6	NO.8	NO.10	NO.12	NO.14													
3/8	■																	
1/2	■	■	■															
5/8	■	■	■															
3/4	■	■	■	■	■													
1	■	■	■	■	■													
1.1/4		■	■	■	■													
1.1/2	■	■	■	■	■													
2		■	■	■	■													
2.1/2			■															

[CLICK HERE TO RETURN TO THE CONTENTS PAGE](#)



+ 37 064 411 786



Inquiry@invayear.com

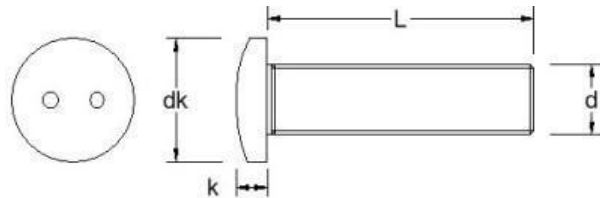

www.invayear.com

2HOLE PAN SCREWS

Material grades: A2:■

dk	5.8	7.8	9.8	11.8														
k	1.7	2.4	2.9	3.5														
Pitch	0.5	0.7	0.8	1.0														
Length/dim	M3	M4	M5	M6														
6		■																
8			■															
10	■	■																
12	■	■	■	■														
16	■	■	■	■														
20		■	■	■														
25		■	■	■														
30			■	■														
35				■														
40				■														
45				■														
50				■														

[CLICK HERE TO RETURN TO THE CONTENTS PAGE](#)



+ 37 064 411 786

Inquiry@invayear.com

www.invayear.com

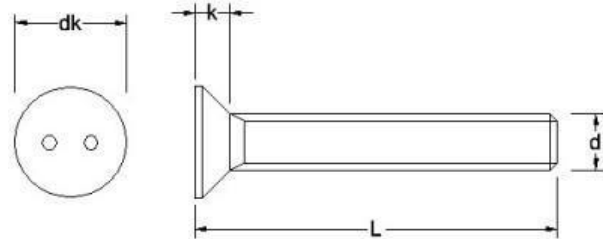
SECURITY SCREWS
2HOLE COUNTERSUNK SCREWS

Material grades: A2:■

dk	5.5	7.3	9.0	10.7														
k	1.7	2.2	2.5	3.0														
Pitch	0.5	0.7	0.8	1.0														
Length/dim	M3	M4	M5	M6														
8	■																	
10	■	■																
12	■	■	■	■														
16	■	■	■	■														
20	■	■	■	■														
25	■	■	■	■														
30	■	■	■	■														
35	■	■	■															
40				■														

[CLICK HERE TO RETURN TO THE CONTENTS PAGE](#)



+ 37 064 411 786



Inquiry@invayear.com

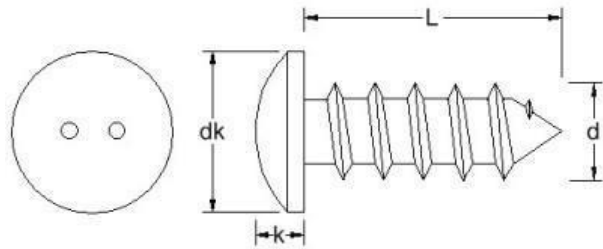

www.invayear.com

SECURITY SCREWS
2HOLE PAN SELF TAPPING SCREWS

Material grades: A2: ■

dk	5.4	6.7	8.0	9.2	10.5	12.2											
k	1.6	2.0	2.3	2.7	3.1	3.5											
Length/dim	NO.4	NO.6	NO.8	NO.10	NO.12	NO.14											
3/8	■	■	■	■													
1/2	■	■	■	■	■												
5/8		■	■	■		■											
3/4	■	■	■	■		■											
1	■	■	■	■	■	■											
1.1/4		■	■	■	■	■											
1.1/2	■	■	■	■	■	■											
2		■	■	■	■	■											
2.1/2				■													

[CLICK HERE TO RETURN TO THE CONTENTS PAGE](#)

+ 37 064 411 786

Inquiry@invayear.com

www.invayear.com

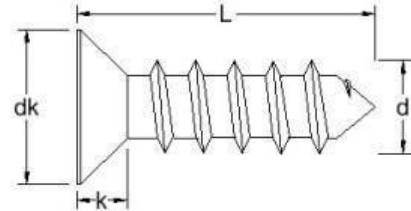
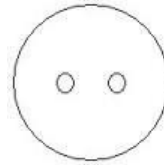
2HOLE COUNTERSUNK SELF TAPPING SCREWS

Material grades: A2: ■

dk	5.5	6.6	7.8	8.9	10.1	12.3												
k	1.7	2.1	2.5	3	3.4	3.9												
Length/dim	NO.4	NO.6	NO.8	NO.10	NO.12	NO.14												
3/8	■	■	■															
1/2	■	■	■	■														
5/8		■	■	■		■												
3/4	■	■	■	■		■												
1	■	■	■	■	■	■												
1.1/4	■	■	■	■	■	■												
1.1/2	■	■	■	■	■	■												
2		■	■	■	■	■												
2.1/2				■														

[CLICK HERE TO RETURN TO THE CONTENTS PAGE](#)

+ 37 064 411 786

Inquiry@invayear.com

www.invayear.com

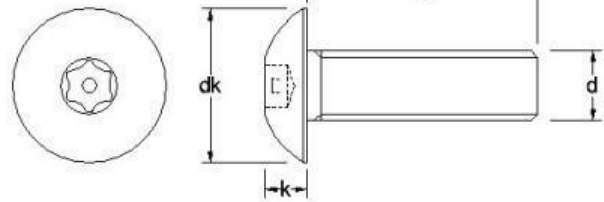

Material grades: A2: ■

dk (Max)	0.213	0.262	0.312	0.361	0.361	0.437	0.547	0.656									
k (Max)	0.059	0.073	0.087	0.101	0.101	0.132	0.166	0.199									
Length/dim	4-40	6-32	8-32	10-24	10-32	1/4-20	5/16-18	3/8-16									
1/4	■	■	■	■													
3/8	■	■	■	■	■												
1/2	■	■	■	■	■	■											
5/8			■	■	■	■											
3/4		■	■	■	■	■	■	■									
1		■	■	■	■	■	■	■									
1.1/4			■	■	■	■	■	■									
1.1/2				■	■	■	■	■									
2						■											

[CLICK HERE TO RETURN TO THE CONTENTS PAGE](#)



+ 37 064 411 786



Inquiry@invayear.com

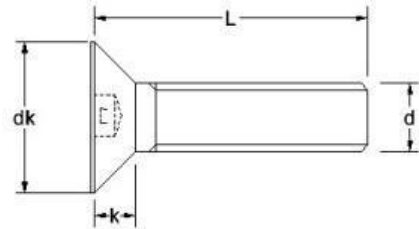
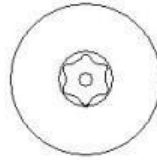

www.invayear.com

PIN TX COUNTERSUNK SCREWS

Material grades: A2: ■

dk (Max)	0.307	0.359	0.411	0.411	0.531													
k (Max)	0.097	0.112	0.127	0.127	0.161													
Length/dim	6-32	8-32	10-24	10-32	1/4-20													
3/8	■	■																
1/2	■	■	■	■	■													
3/4	■	■	■	■	■													
1	■	■	■	■	■													
1.1/2					■													

[CLICK HERE TO RETURN TO THE CONTENTS PAGE](#)

+ 37 064 411 786

Inquiry@invayear.com

www.invayear.com

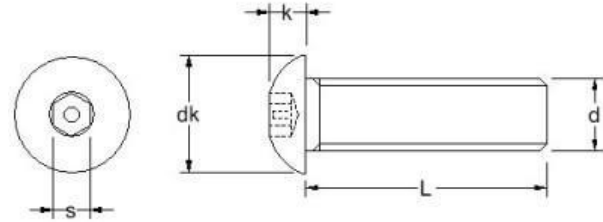
 Material grades: **A2**

dk (Max)	0.262	0.312	0.361	0.361	0.437	0.547	0.656											
k (Max)	0.073	0.087	0.101	0.101	0.132	0.166	0.199											
s	1/8	1/8	5/32	5/32	5/32	3/16	7/32											
Length/dim	6-32	8-32	10-24	10-32	1/4-20	5/16-18	3/8-16											
1/4	■		■	■														
3/8	■	■	■	■														
1/2	■	■	■	■	■	■	■											
5/8			■	■	■													
3/4	■	■	■	■	■	■	■											
1	■	■	■	■	■	■	■											
1.1/4			■	■	■	■	■											
1.1/2		■	■	■	■	■	■											
1.3/4																		
2			■	■	■	■	■											
2.1/4																		
2.1/2																		
2.3/4																		
3																		
3.1/4																		
4																		

CLICK HERE TO RETURN TO THE CONTENTS PAGE



+ 37 064 411 786



Inquiry@invayear.com

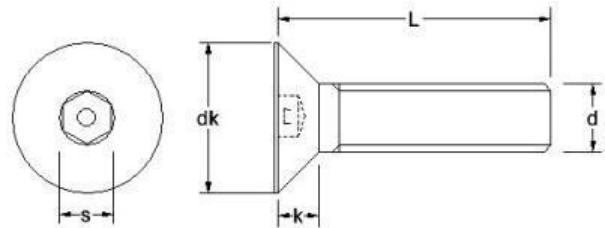

www.invayear.com

PIN HEX COUNTERSUNK SCREWS

Material grades: A2: ■

dk (Max)	0.307	0.359	0.411	0.411	0.531	0.656	0.781											
k (Max)	0.097	0.112	0.127	0.127	0.161	0.198	0.234											
s	1/8	1/8	5/32	5/32	5/32	3/16	7/32											
Length/dim	6-32	8-32	10-24	10-32	1/4-20	5/16-18	3/8-16											
3/8	■	■	■	■														
1/2	■	■	■	■	■	■												
3/4	■	■	■	■	■	■	■											
1		■	■	■	■	■	■											
1.1/4					■													
1.1/2			■	■	■													

[CLICK HERE TO RETURN TO THE CONTENTS PAGE](#)

+ 37 064 411 786

Inquiry@invayear.com

www.invayear.com

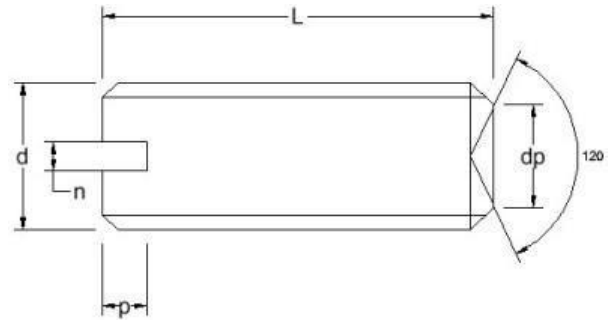
SLOTTED SET SCREWS CUP POINT DIN 438

Material grades: A2: ■

dp (Max)	2	2.5	3	5														
n	0.6	0.8	1	1.2														
Pitch	0.7	0.8	1.0	1.25														
p	1.12	1.28	1.6	2														
Length/dim	M4	M5	M6	M8														
6	■		■															
8	■																	
10	■	■		■														
12	■			■														
16	■	■	■	■														
20	■	■		■														
25		■		■														
35				■														

[CLICK HERE TO RETURN TO THE CONTENTS PAGE](#)

+ 37 064 411 786

Inquiry@invayear.com

www.invayear.com

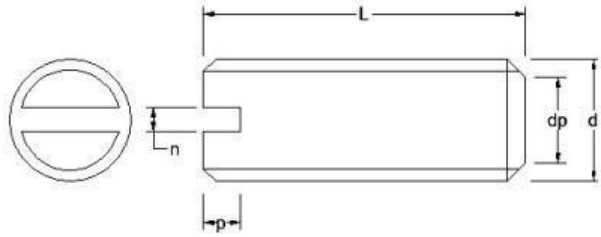
SLOTTED SET SCREWS FLAT POINT DIN 551

Material grades: A2: ■ A4: ◆

dp (Max)	*	*	*	1	1.5	2	2.5	3.5	4	5.5							
n	0.2	0.2	0.25	0.25	0.4	0.4	0.6	0.8	1	1.2							
Pitch	0.25	0.3	0.35	0.4	0.45	0.5	0.7	0.8	1.0	1.25							
p	0.4	0.48	0.56	0.64	0.72	0.8	1.12	1.28	1.6	2							
Length/dim	M1.2	M1.4	M1.6	M2	M2.5	M3	M4	M5	M6	M8	M10	M12					
1.5	■																
2	■	■	■	■													
2.5				■													
3	■	■	■	■	■	■											
4	■	■	■	■	■	■	◆	■									
5	■	■	■	■	■	■	◆	◆									
6	■	■	■	■	■	■	◆	◆	◆	■							
8	■	■	■	■	■	■	◆	◆	◆	◆	■						
10	■	■	■	■	■	■	◆	◆	◆	◆	◆	◆					
12				■	■	■	◆	◆	◆	◆	◆	◆	■				
16					■	■	◆	◆	◆	◆	◆	■					
18										■	◆						
20						■	◆	◆	◆	◆	◆	◆					
25							◆	◆	◆	◆	◆	◆	■				
30							◆	◆	◆	◆	◆	◆	■				
35							◆	◆	◆	◆	◆	◆					
40							◆	◆	◆	◆	◆	◆	■				
45							■	■	◆	◆	◆	◆					
50							■	■	◆	◆	◆	◆					
55									◆								
60									◆	◆	◆	◆					
70									■	■	■	■					
80										■	■	■					
90											■	■					

CLICK HERE TO RETURN TO THE CONTENTS PAGE



+ 37 064 411 786



Inquiry@invayear.com

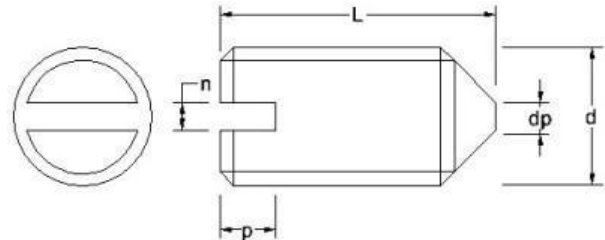

www.invayear.com

SLOTTED SET SCREWS CONE POINT DIN 553

Material grades: A2: ■ A4: ◆

n (Min)	0.31	0.31	0.46	0.46	0.66	0.86	1.06	1.26	1.66	2.10							
Pitch	0.35	0.4	0.45	0.5	0.7	0.8	1.0	1.25	1.5	1.75							
p (Min)	0.56	0.64	0.72	0.80	1.12	1.28	1.60	2.00	2.40	2.80							
Length/dim	M1.6	M2	M2.5	M3	M4	M5	M6	M8	M10	M12							
2	■	■															
2.5		■															
3	■	■	■	■													
4	■	■	■	■	■												
5	■	■	■	■	■												
6	■	■	■	■	◆	◆	◆										
8	■	■	■	■	◆	◆	◆	◆									
10	■	■	■	■	◆	◆	◆	◆	◆								
12		■		■	◆	◆	◆	◆	◆								
14				■													
16				■	◆	◆	◆	◆	◆								
18							■	■									
20				■	◆	◆	◆	◆	◆	■							
25					◆	◆	◆	◆	◆								
30					◆	◆	◆	◆	◆								
35						■	◆	■	■	■							
40					■	■	◆	◆	◆	■							
45								■									
50					■	■		◆	◆								

[CLICK HERE TO RETURN TO THE CONTENTS PAGE](#)

+ 37 064 411 786

Inquiry@invayear.com

www.invayear.com

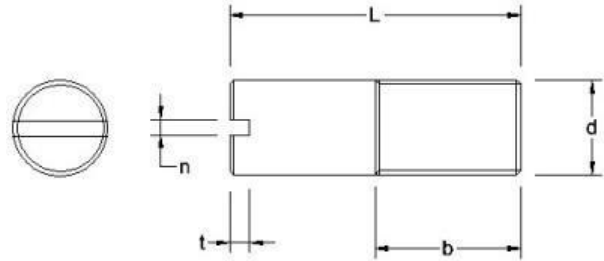
SLOTTED SET SCREWS PART THREAD DIN 427

Material grades: A2: ■ A4: ◆

	b	3.6	4.8	6.0	7.2	9.6	12.0											
n		0.4	0.6	0.8	1	1.2	1.6											
Pitch		0.5	0.7	0.8	1.0	1.25	1.5											
t		1.25-1.50	1.75-2.05	2.00-2.35	2.50-2.90	3.10-3.60	3.75-4.25											
Length/dim	M3	M4	M5	M6	M8	M10												
6	■◆																	
8	■◆	■◆	■◆															
10	■◆	■◆	■◆															
12	■◆	■◆	■◆	■◆														
16	■◆	■◆	■◆	■◆	■◆													
20	■◆	■◆	■◆	■◆	■◆	■◆												
25		■◆	■◆	■◆	■◆	■◆	■◆											
30		■◆	■◆	■◆	■◆	■◆	■◆											
35		■◆	■◆	■◆	■◆	■◆	■◆											
40		■◆	■◆	■◆	■◆	■◆	■◆											
45						■◆	■◆											
50						■◆	■◆											

CLICK HERE TO RETURN TO THE CONTENTS PAGE



+ 37 064 411 786



Inquiry@invayear.com

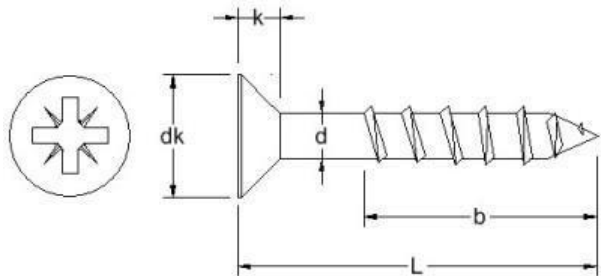

www.invayear.com

 Material grades: **A2**

b	0.6 x L	0.6 x L	0.6 x L	0.6 x L	0.6 x L	0.6 x L											
dk	5.6	6.5	7.5	8.3	9.2	11											
k	1.65	1.93	2.2	2.35	2.5	3											
Length/dim	3.0	3.5	4.0	4.5	5.0	6.0											
12	■	■															
16	■	■	■														
20	■	■	■	■	■												
25	■	■	■	■	■	■											
30	■	■	■	■	■	■											
35		■	■	■	■	■											
40		■	■	■	■	■											
45			■	■	■	■											
50		■	■	■	■	■											
60			■	■	■	■											
65				■	■	■											
70			■	■	■	■											
75					■	■											
80					■	■											
90					■	■											
100					■	■											
110						■											
120						■											

[CLICK HERE TO RETURN TO THE CONTENTS PAGE](#)



+ 37 064 411 786

Inquiry@invayear.com

www.invayear.com

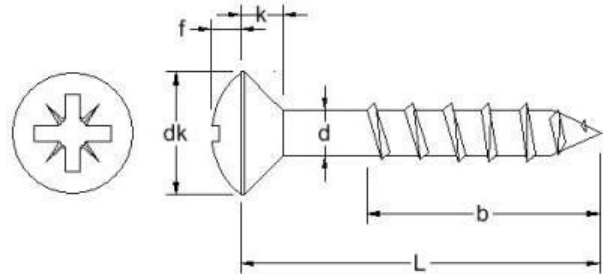
POZI RAISED COUNTERSUNK WOODSCREWS DIN 7995 Z

Material grades: A2:■

b	0.6 x L	0.6 x L	0.6 x L	0.6 x L	0.6 x L	0.6 x L												
dk	5.6	6.5	7.5	8.3	9.2	11												
f	0.75	0.9	1.0	1.1	1.25	1.5												
k	1.65	1.93	2.2	2.35	2.5	3												
Length/dim	3.0	3.5	4.0	4.5	5.0	6.0												
12	■	■																
16	■	■	■															
20	■	■	■	■	■	■												
25	■	■	■	■	■	■												
30	■	■	■	■	■	■												
35	■	■	■	■	■	■												
40			■	■	■	■												
45			■	■	■	■												
50			■	■	■	■												
55				■														
60			■	■	■	■												
65				■	■	■												
70			■	■	■	■												
75					■	■												
80				■	■	■												
90				■	■	■												
100				■	■	■												

[CLICK HERE TO RETURN TO THE CONTENTS PAGE](#)



+ 37 064 411 786



Inquiry@invayear.com

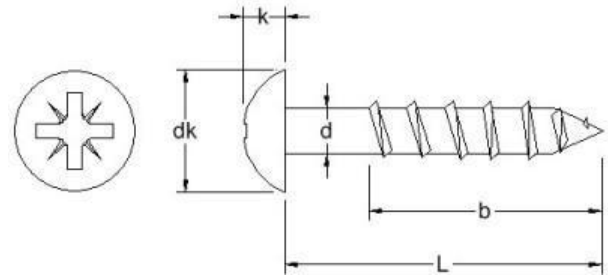

www.invayear.com

DIN 7996 Z
POZI ROUND WOODSCREWS DIN 7996 Z

 Material grades: **A2**

b	0.6 x L	0.6 x L	0.6 x L	0.6 x L	0.6 x L	0.6 x L												
dk	6.1	7	8	9	10	12												
k	2.1	2.35	2.8	3.1	3.5	4.2												
Length/dim	3.0	3.5	4.0	4.5	5.0	6.0												
12	■																	
16	■	■	■		■													
20	■	■	■		■													
25	■	■	■	■	■													
30	■	■	■	■	■	■												
35	■	■	■	■	■	■												
40		■	■	■	■	■												
45			■	■	■	■												
50		■	■	■	■	■												
60			■	■	■	■												
65				■														
70			■	■	■	■												
80			■		■	■												
90					■													

CLICK HERE TO RETURN TO THE CONTENTS PAGE



+ 37 064 411 786



Inquiry@invayear.com

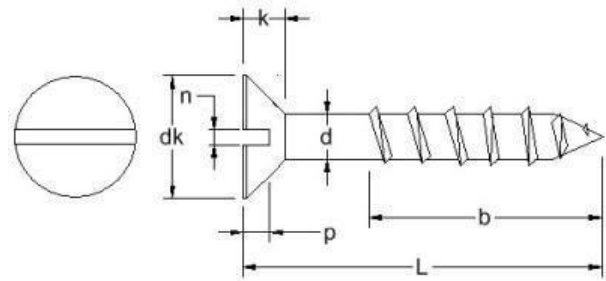

www.invayear.com

SLOT COUNTERSUNK WOODSCREWS DIN 97

Material grades: A2: ■ A4: ◆

b	0.6 x L	0.6 x L	0.6 x L	0.6 x L	0.6 x L	0.6 x L	0.6 x L	0.6 x L	0.6 x L								
dk	4.7	5.6	6.5	7.5	8.3	9.2	10.2	11	14.5								
k	1.5	1.65	1.93	2.2	2.35	2.5	2.75	3	4								
n	0.6	0.8	0.8	1.0	1.0	1.2	1.2	1.6	2.0								
p (Max)	0.7	0.85	1.0	1.1	1.2	1.3	1.4	1.6	2.1								
Length/dim	2.5	3.0	3.5	4.0	4.5	5.0	5.5	6.0	8.0								
10	◆	◆		◆													
12	◆	◆	◆	◆													
16	◆	◆	◆	◆	◆	◆											
20	◆	◆	◆	◆	◆	◆	■	◆									
25	◆	◆	◆	◆	◆	◆	■	◆									
30		◆	◆	◆	◆	◆	■	◆	◆								
35		◆	◆	◆	◆	◆	■	◆									
40		◆	◆	◆	◆	◆	■	◆	◆								
45			◆	◆	◆	◆	■	◆									
50			◆	◆	◆	◆	■	◆	◆								
60				◆	◆	◆	■	◆	◆								
65						◆	■	◆									
70				◆	◆	◆	■	◆	◆								
75						◆	■	◆	◆								
80					◆	◆	■	◆	◆								
90						◆	■	◆	◆								
100						◆	■	◆	◆								
110								■									
120								■									

[CLICK HERE TO RETURN TO THE CONTENTS PAGE](#)

+ 37 064 411 786

Inquiry@invayear.com

www.invayear.com

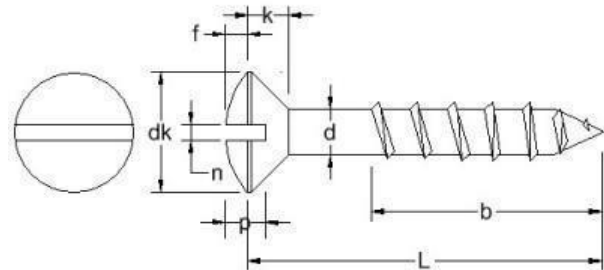
SLOT RAISED COUNTERSUNK WOODSCREWS DIN 95

Material grades: A2: ■ A4: ◆

b	0.6 x L	0.6 x L	0.6 x L	0.6 x L	0.6 x L	0.6 x L	0.6 x L	0.6 x L										
dk	4.7	5.6	6.5	7.5	8.3	9.2	10.2	11										
f	0.6	0.75	0.9	1.0	1.1	1.25	1.4	1.5										
k	1.5	1.65	1.93	2.2	2.35	2.5	2.75	3										
n	0.6	0.8	0.8	1.0	1.0	1.2	1.2	1.6										
p (Max)	1.2	1.45	1.7	1.9	2.1	2.3	2.5	2.8										
Length/dim	2.5	3.0	3.5	4.0	4.5	5.0	5.5	6.0										
10	◆	◆																
12	◆	◆	◆	◆														
16	◆	◆	◆	◆	◆	◆												
20	◆	◆	◆	◆	◆	◆	■	◆										
25	◆	◆	◆	◆	◆	◆	■	◆										
30		◆	◆	◆	◆	◆	■	◆										
35		◆	◆	◆	◆	◆	■	◆										
40		◆	◆	◆	◆	◆	■	◆										
45			◆	◆	◆	◆	■	◆										
50			◆	◆	◆	◆	■	◆										
55						◆		◆										
60				◆	◆	◆	■	◆										
65					◆	◆	■	◆										
70				◆	◆	◆	■	◆										
75						◆	■	◆										
80						◆	■	◆										
90						◆	■	◆										
100						◆	■	■										
110								■										
120								■										

[CLICK HERE TO RETURN TO THE CONTENTS PAGE](#)

+ 37 064 411 786

Inquiry@invayear.com

www.invayear.com

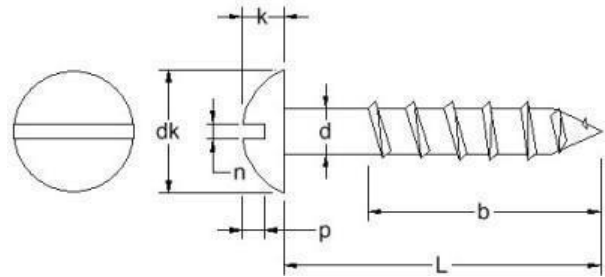
SLOT ROUND WOODSCREWS DIN 96

Material grades: A2: ■ A4: ◆

b	0.6 x L	0.6 x L	0.6 x L	0.6 x L	0.6 x L	0.6 x L	0.6 x L	0.6 x L									
dk	5	6	7	8	9	10	11	12									
k	1.7	2.1	2.4	2.8	3.1	3.5	3.8	4.2									
n	0.6	0.8	0.8	1.0	1.0	1.2	1.2	1.6									
p (Max)	1.1	1.35	1.6	1.8	2.0	2.3	2.5	2.7									
Length/dim	2.5	3.0	3.5	4.0	4.5	5.0	5.5	6.0									
10	■◆	■◆															
12	■◆	■◆	■◆	■◆													
16	■◆	■◆	■◆	■◆	■◆	■◆											
20	■◆	■◆	■◆	■◆	■◆	■◆		■◆									
25	■◆	■◆	■◆	■◆	■◆	■◆	■◆	■◆	■◆								
30		■◆	■◆	■◆	■◆	■◆	■◆	■◆	■◆	■◆							
35		■◆	■◆	■◆	■◆	■◆	■◆	■◆	■◆	■◆							
40		■◆	■◆	■◆	■◆	■◆	■◆	■◆	■◆	■◆							
45			■◆	■◆	■◆	■◆	■◆	■◆	■◆	■◆							
50			■◆	■◆	■◆	■◆	■◆	■◆	■◆	■◆							
55						■◆											
60				■◆	■◆	■◆	■◆	■◆	■◆	■◆							
65					■◆	■◆	■◆	■◆	■◆	■◆							
70				■◆	■◆	■◆	■◆	■◆	■◆	■◆							
75						■◆	■◆	■◆	■◆	■◆							
80							■◆	■	■◆								
90							■◆	■	■◆								
100							■◆	■	■◆								
110									■								
120										■							

CLICK HERE TO RETURN TO THE CONTENTS PAGE



+ 37 064 411 786



Inquiry@invayear.com

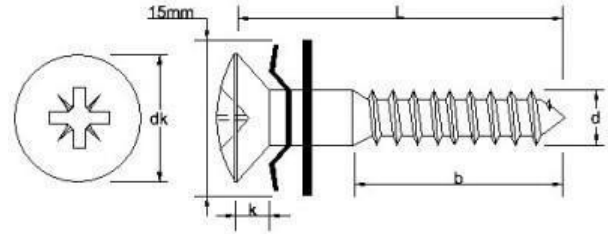

www.invayear.com

 Material grades: **A2**

b	0.6 x L	0.6 x L																			
Drive #	2	2																			
dk	8.3	9.2																			
k	2.35	2.5																			
Length/dim	4.5	5.0																			
20	■																				
25	■																				
30	■																				
35	■																				
40	■																				
45	■																				
50	■																				
55	■																				
60	■																				
65	■																				
70	■																				
80	■																				
90	■																				
100	■																				
120	■																				
150	■																				
180		■																			
200		■																			
220		■																			
250		■																			
280		■																			
300		■																			

CLICK HERE TO RETURN TO THE CONTENTS PAGE



+ 37 064 411 786



Inquiry@invayear.com

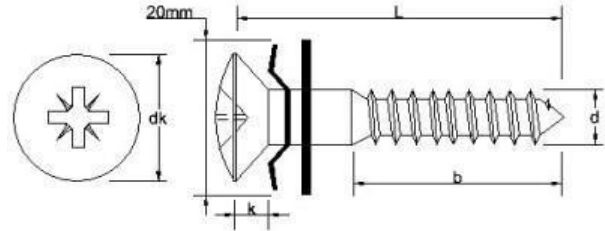

www.invayear.com

POZI RAISED COUNTERSUNK WOODSCREWS DIN 7995 20MM SEALING WASHER

Material grades: A2: ■

b	0.6 x L	0.6 x L																	
Drive #	2	2																	
dk	8.3	9.2																	
k	2.35	2.5																	
Length/dim	4.5	5.0																	
20	■																		
25	■																		
30	■																		
35	■																		
40	■																		
45	■																		
50	■																		
55	■																		
60	■																		
65	■																		
70	■																		
80	■																		
100	■																		
120	■																		
150	■																		
180		■																	
200		■																	
220		■																	
250		■																	
280		■																	
300		■																	

[CLICK HERE TO RETURN TO THE CONTENTS PAGE](#)

+ 37 064 411 786

Inquiry@invayear.com

www.invayear.com

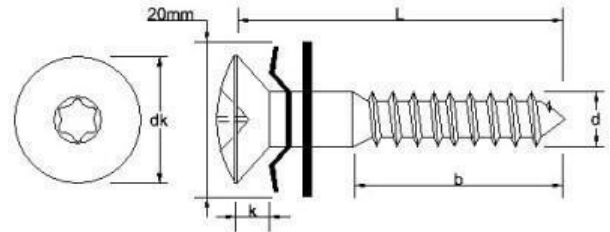
TX RAISED COUNTERSUNK WOODSCREWS DIN 7995 20MM SEALING WASHER

Material grades: A2:■

b	0.6 x L	0.6 x L																	
Drive #	TX20	TX20																	
dk	8.3	9.2																	
k	2.35	2.5																	
Length/dim	4.5	5.0																	
20	■																		
25	■																		
30	■																		
35	■																		
40	■																		
45	■																		
50	■																		
55	■																		
60	■																		
65	■																		
70	■																		
80	■																		
100	■																		
120	■																		
150	■																		
180		■																	
200		■																	
220		■																	
250		■																	
280		■																	
300		■																	

[CLICK HERE TO RETURN TO THE CONTENTS PAGE](#)

+ 37 064 411 786

Inquiry@invayear.com

www.invayear.com

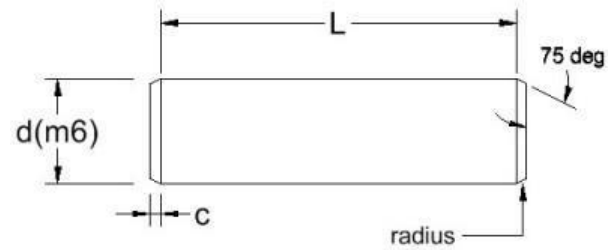
DOWEL PINS DIN 7

Material grades: A2: ■ A4: ◆

c	0.15	0.23	0.3	0.4	0.45	0.6	0.75	0.9	1.2	1.5	1.8	2.5	3				
Length/dim	1.0	1.5	2.0	2.5	3.0	4.0	5.0	6.0	8.0	10	12	16	20				
3	◆	■	■														
4	◆	◆	◆	◆	◆												
5	◆	◆	◆	◆	◆	◆											
6	◆	◆	◆	◆	◆	◆	◆										
8	◆	◆	◆	◆	◆	◆	◆	◆									
10	◆	◆	◆	◆	◆	◆	◆	◆	◆	◆	■						
12	◆	◆	◆	◆	◆	◆	◆	◆	◆	◆	◆						
14	◆	◆	◆	◆	◆	◆		◆	◆	◆	◆						
16	◆	◆	◆	◆	◆	◆	◆	◆	◆	◆	◆						
18	■	◆	◆	◆	◆	◆	◆	◆	◆	◆	◆						
20	■	◆	◆	◆	◆	◆	◆	◆	◆	◆	◆						
22							◆										
24		◆	◆	◆	◆	◆	◆	◆	◆	◆	◆						
26										◆							
28		◆	◆	■	◆	◆	◆	◆	◆	◆	◆	◆					
30					■			◆	◆	◆	◆						
32			■	■	◆	◆	◆	◆	◆	◆	◆	◆	◆				
36					◆	◆	◆	◆	◆	◆	◆	◆	◆	◆			
40					◆	◆	◆	◆	◆	◆	◆	◆	◆	◆			
45						◆	◆	◆	◆	◆	◆	◆	◆				
50						◆	◆	◆	◆	◆	◆	◆	◆				
55								◆	■	◆							
60						■		◆	◆	◆	◆	◆	◆				
70								◆	◆	◆	◆	◆	◆				
80								■	◆	◆	◆	◆	◆				
90									■	◆	◆	◆	◆				
100										◆	◆	◆	◆				
120												■					

CLICK HERE TO RETURN TO THE CONTENTS PAGE



+ 37 064 411 786



Inquiry@invayear.com

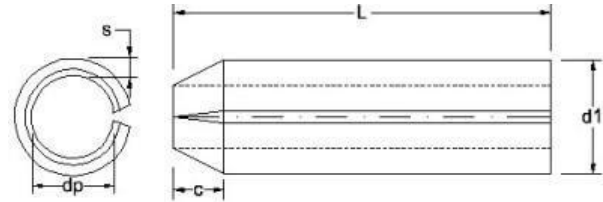

www.invayear.com

SLOTTED SPRING PINS DIN 1481/ISO 8752

Material grades: A2: ■

c	0.15	0.25	0.35	0.4	0.5	0.6	0.65	0.8	0.9	1.2	2.0	2.0	2.0	*			
d1 (Min)	1.2	1.7	2.3	2.8	3.3	3.8	4.4	4.9	5.4	6.4	8.5	10.5	12.5	*			
dp (Min)	0.8	1.1	1.5	1.8	2.1	2.3	2.8	2.9	3.4	3.9	5.5	6.5	7.5	*			
s	0.2	0.3	0.4	0.5	0.6	0.75	0.8	1.0	1.0	1.25	1.5	2.0	2.5	*			
Length/dim	1.0	1.5	2.0	2.5	3.0	3.5	4.0	4.5	5.0	6.0	8.0	10	12	14			
4	■	■	■	■	■	■	■										
5	■	■	■	■	■	■	■										
6	■	■	■	■	■	■	■		■								
8	■	■	■	■	■	■	■		■								
10	■	■	■	■	■	■	■	■	■	■	■	■	■				
12	■	■	■	■	■	■	■		■	■	■	■	■				
14	■	■	■	■	■	■	■	■	■	■	■	■	■				
16	■	■	■	■	■	■	■	■	■	■	■	■	■				
18	■	■	■	■	■	■	■	■	■	■	■	■	■				
20	■	■	■	■	■	■	■	■	■	■	■	■	■	■			
22			■	■	■	■	■	■	■	■	■	■	■				
24			■	■	■		■	■	■	■	■	■	■				
25					■	■	■		■								
26			■	■	■	■	■	■	■	■	■	■	■				
28			■	■	■	■	■	■	■	■	■	■	■				
30			■	■	■	■	■	■	■	■	■	■	■				

[CLICK HERE TO RETURN TO THE CONTENTS PAGE](#)

+ 37 064 411 786

Inquiry@invayear.com

www.invayear.com

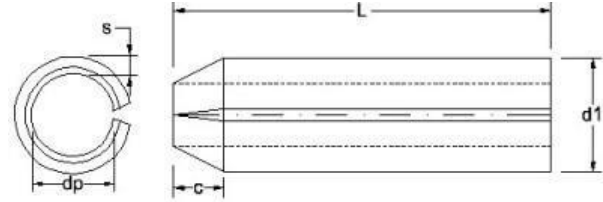
SLOTTED SPRING PINS DIN 1481/ISO 8752

Material grades: A2:■

c	0.15	0.25	0.35	0.4	0.5	0.6	0.65	0.8	0.9	1.2	2.0	2.0	2.0	*			
d1 (Min)	1.2	1.7	2.3	2.8	3.3	3.8	4.4	4.9	5.4	6.4	8.5	10.5	12.5	*			
dp (Min)	0.8	1.1	1.5	1.8	2.1	2.3	2.8	2.9	3.4	3.9	5.5	6.5	7.5	*			
s	0.2	0.3	0.4	0.5	0.6	0.75	0.8	1.0	1.0	1.25	1.5	2.0	2.5	*			
Length/dim	1.0	1.5	2.0	2.5	3.0	3.5	4.0	4.5	5.0	6.0	8.0	10	12	14			
32					■	■	■	■	■	■	■	■					
35									■								
36					■	■	■	■	■	■	■	■	■	■			
40					■	■	■	■	■	■	■	■	■	■			
45							■	■	■	■	■	■	■	■			
50							■	■	■	■	■	■	■	■			
55									■	■	■	■					
60									■	■	■	■	■				
65									■		■	■					
70									■	■	■	■	■				
75										■	■	■					
80										■	■	■					
85											■	■					
90											■	■					
95											■						
100											■	■					
120												■					

[CLICK HERE TO RETURN TO THE CONTENTS PAGE](#)

+ 37 064 411 786

Inquiry@invayear.com

www.invayear.com

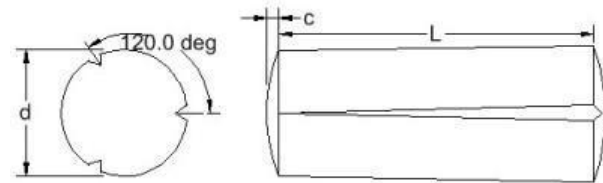

Material grades: A2: ■

c	0.30	0.40	0.50	0.63	0.80	1.00												
Length/dim	2	3	4	5	6	8												
6	■																	
8	■	■	■	■														
10	■	■	■	■	■	■												
12	■	■	■	■	■	■												
16	■	■	■	■	■	■												
18	■	■	■	■	■	■												
20	■	■	■	■	■	■												
25		■	■	■	■	■												
30			■	■	■	■												
35			■	■	■	■												
40			■	■	■	■												
45					■	■												
50					■	■												
60					■	■												

[CLICK HERE TO RETURN TO THE CONTENTS PAGE](#)



+ 37 064 411 786



Inquiry@invayear.com

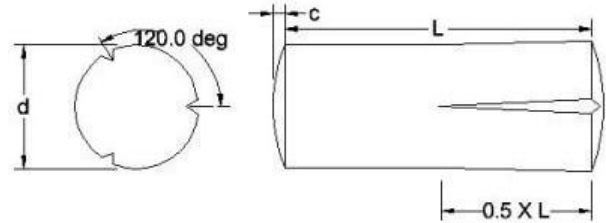

www.invayear.com

HALF LENGTH TAPER GROOVED PINS DIN 1472

Material grades: A2:■

c	0.30	0.40	0.50	0.60	0.80	1.00												
Length/dim	2	3	4	5	6	8												
3	■																	
4	■																	
5	■																	
6	■																	
8	■	■	■	■														
10	■	■	■	■	■	■												
12	■	■	■	■	■	■												
16	■	■	■	■	■	■												
18	■	■	■	■	■	■												
20	■	■	■	■	■	■												
25		■	■	■	■	■												
30			■	■	■	■												
35			■	■	■	■												
40			■	■	■	■												
45					■	■												
50					■	■												
60					■	■												

[CLICK HERE TO RETURN TO THE CONTENTS PAGE](#)



+ 37 064 411 786



Inquiry@invayear.com



www.invayear.com

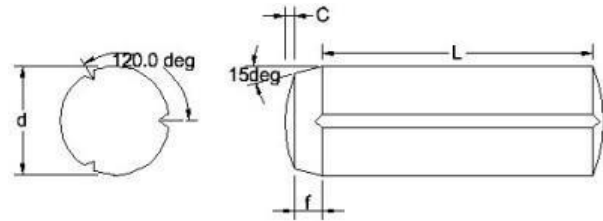

Material grades: A2:■

c	0.25	0.40	0.50	0.60	0.80	1.00												
f	0.9	1.3	1.8	2.0	2.5	2.8												
Length/dim	2	3	4	5	6	8												
5	■																	
6	■	■																
8	■	■	■															
10	■	■	■	■	■	■												
12	■	■	■	■	■	■	■											
14	■	■																
16	■	■	■	■	■	■	■											
18	■	■	■	■	■	■	■											
20	■	■	■	■	■	■	■											
22		■		■														
25		■	■	■	■	■	■											
30		■	■	■	■	■	■											
32		■	■	■														
35			■	■	■	■	■											
36					■													
40			■	■	■	■	■											
45				■	■	■	■											
50			■	■	■	■	■											
60					■	■												
70						■												

[CLICK HERE TO RETURN TO THE CONTENTS PAGE](#)



+ 37 064 411 786



Inquiry@invayear.com

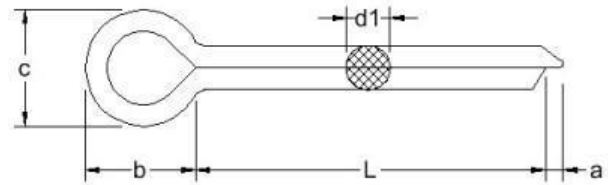

www.invayear.com

SPLIT PINS DIN 94

Material grades: A2: ■ A4: ◆

	0.80-1.60	1.25-2.50	1.25-2.50	1.25-2.00	1.25-2.00	1.60-3.20	2.00-4.00	2.00-4.00	2.00-4.00	2.00-4.00	3.20-6.30	3.20-6.30				
a	0.80-1.60	1.25-2.50	1.25-2.50	1.25-2.00	1.25-2.00	1.60-3.20	2.00-4.00	2.00-4.00	2.00-4.00	2.00-4.00	3.20-6.30	3.20-6.30				
b	3	3	3.2	4	5	6.4	8	10	12.6	16	20	26				
c	1.60-1.80	1.70-2.00	2.40-2.80	3.20-3.60	4.00-4.60	5.10-5.80	6.50-7.40	8.00-9.20	10.30-11.80	13.10-15.00	16.60-19.00	21.70-24.80				
d1	0.8-0.9	0.9-1.0	1.3-1.4	1.7-1.8	2.1-2.3	2.7-2.9	3.5-3.7	4.4-4.6	5.7-5.9	7.3-7.5	9.3-9.5	12.1-12.4				
Length/dim	1.0	1.2	1.6	2.0	2.5	3.2	4.0	5.0	6.3	8.0	10	13				
6	◆	◆	◆	■												
8	◆	◆	◆	◆												
10	◆	◆	◆	◆	■	◆										
12	◆	◆	◆	◆	◆	◆										
16	◆	◆	◆	◆	◆	◆	◆	◆								
18	◆	◆	◆	◆	◆	◆	◆	◆	◆							
20	◆	◆	◆	◆	◆	◆	◆	◆	◆	◆						
22	◆	◆	◆	◆	◆	◆	◆	◆	◆	◆						
25	◆	◆	◆	◆	◆	◆	◆	◆	◆	◆						
28	◆	◆	◆	◆	◆	◆	◆	◆	◆	◆						
32	◆	◆	◆	◆	◆	◆	◆	◆	◆	◆	◆	■				
36	■	◆	◆	◆	◆	◆	◆	◆	◆	◆	◆	■				
40	■	◆	◆	◆	◆	◆	◆	◆	◆	◆	◆	■				
45	■	◆	◆	◆	◆	◆	◆	◆	◆	◆	◆	◆	◆			
50			■	■	◆	◆	◆	◆	◆	◆	◆	◆				
56						◆	◆	◆	◆	◆	◆	◆	◆			
63						◆	◆	◆	◆	◆	◆	◆	◆			
71						■	◆	◆	◆	◆	◆	◆	◆			
80						■	◆	◆	◆	◆	◆	◆	◆			
90							◆	◆	◆	◆	◆	◆	◆	◆		
100							◆	◆	◆	◆	◆	◆	◆	◆		
112									◆	◆	◆	◆	◆	◆		
125									■	◆	◆	◆	◆	◆		
140										◆	◆	◆	◆	◆		

CLICK HERE TO RETURN TO THE CONTENTS PAGE



+ 37 064 411 786



Inquiry@invayear.com

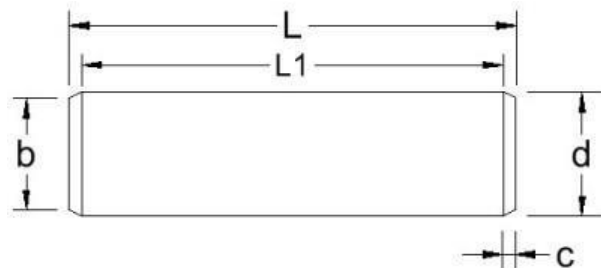

www.invayear.com

ANSI B18.8.2
DOWEL PINS ANSI B18.8.2

Material grades: A2: ■ A4: ◆

b (Max)	0.058	0.089	0.120	0.180	0.240	0.302	0.365	0.424	0.486	0.611	0.735						
c (Max)	0.020	0.031	0.041	0.062	0.083	0.104	0.125	0.146	0.167	0.208	0.250						
Hole Size	0.0620 - 0.0625	0.0932 - 0.0937	0.1245 - 0.1250	0.1870 - 0.1875	0.2495 - 0.2500	0.3120 - 0.3125	0.3745 - 0.3750	0.4370 - 0.4375	0.4995 - 0.5000	0.6245 - 0.6250	0.7495 - 0.7500						
Length/dim	1/16	3/32	1/8	3/16	1/4	5/16	3/8	7/16	1/2	5/8	3/4						
3/16	◆																
1/4	◆	◆	◆														
5/16	◆	◆	◆														
3/8	◆	◆	◆	◆													
1/2	◆	◆	◆	◆	◆	◆	◆										
5/8	◆	◆	◆	◆	◆	◆	◆										
3/4	◆	◆	◆	◆	◆	◆	◆	■	■								
7/8		■		◆	◆	◆	◆	■									
1	◆	◆	◆	◆	◆	◆	◆	■	■	■							
1.1/4			◆	◆	◆	◆	◆	■	■	■							
1.1/2			◆	◆	◆	◆	◆	■	■	■	■						
1.3/4			◆	◆	◆	◆	◆	■	■	■	■						
2			◆	◆	◆	◆	◆	■	■	■	■						
2.1/4					◆	◆	◆	■	■	■	■						
2.1/2					◆	◆	◆	■	■	■	■						
3					◆	◆	◆	■	■	■	■						
3.1/2					◆	◆	◆	■	■	■	■						
4					◆	◆	◆	■	■	■	■						
4.1/2							◆	■	■	■	■						
5							◆	■	■	■	■						
5.1/2									■	■	■						
6									■	■	■						

CLICK HERE TO RETURN TO THE CONTENTS PAGE



+ 37 064 411 786



Inquiry@invayear.com

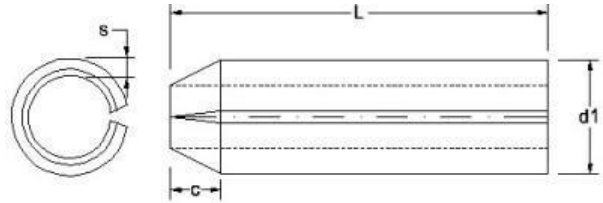

www.invayear.com

SLOTTED SPRING PINS ANSI B18.8.2

Material grades: A2: ■

c (Max)	0.028	0.038	0.044	0.055	0.065	0.080	0.095	0.095	0.110	0.125	0.150						
d1 (Max)	0.069	0.103	0.135	0.199	0.264	0.330	0.395	0.459	0.524	0.653	0.784						
Hole Size	0.062 - 0.065	0.094 - 0.097	0.125 - 0.129	0.187 - 0.192	0.250 - 0.256	0.312 - 0.318	0.375 - 0.382	0.437 - 0.445	0.500 - 0.510	0.625 - 0.636	0.750 - 0.764						
s	0.012	0.022	0.028	0.040	0.048	0.062	0.077	0.077	0.094	0.125	0.150						
Length/dim	1/16	3/32	1/8	3/16	1/4	5/16	3/8	7/16	1/2	5/8	3/4						
3/16		■															
1/4	■	■															
5/16	■	■	■														
3/8	■	■	■														
7/16		■	■														
1/2	■	■	■	■	■												
9/16	■	■															
5/8	■	■	■	■	■												
3/4	■	■	■	■	■	■	■										
7/8		■	■	■	■	■	■										
1		■	■	■	■	■	■	■									
1.1/4		■	■	■	■	■	■	■	■								
1.1/2		■	■	■	■	■	■	■	■	■							
1.3/4			■	■	■	■	■	■	■	■							
2			■	■	■	■	■	■	■	■	■						
2.1/4				■	■	■	■	■	■	■	■	■					
2.1/2				■	■	■	■	■	■	■	■	■					
2.3/4					■	■	■	■	■	■	■	■					
3					■	■	■	■	■	■	■	■	■				
3.1/2						■	■	■	■	■	■	■	■				
4							■	■	■	■	■	■	■				
4.1/2										■	■	■	■				
5											■	■	■				
5.1/2												■	■				
6													■	■			

CLICK HERE TO RETURN TO THE CONTENTS PAGE



+ 37 064 411 786



Inquiry@invayear.com



www.invayear.com

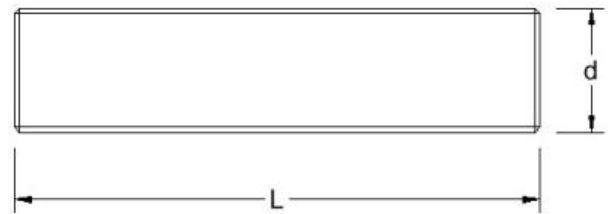

Material grades: A2: ■ A4: ◆

L	1000	1000	1000	1000	1000	1000	1000	1000	1000	1000	1000	1000	1000	1000	1000	1000	1000
Pitch	0.40	0.45	0.50	0.70	0.80	1.00	1.25	1.50	1.75	2.00	2.00	2.50	2.50	3.00	3.50	3.50	4.00
Length/dim	M2	M2.5	M3	M4	M5	M6	M8	M10	M12	M14	M16	M18	M20	M24	M30	M33	M36
IMTR	■◆	■◆	■◆	■◆	■◆	■◆	■◆	■◆	■◆	■◆	■◆	■◆	■◆	■◆	■◆	■◆	■

CLICK HERE TO RETURN TO THE CONTENTS PAGE



+ 37 064 411 786



Inquiry@invayear.com

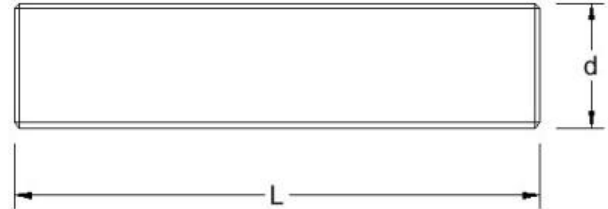

www.invayear.com

THREADED STUDS DIN 976

Material grades: A2:■

Pitch	1.00	1.25	1.50	1.75	2.00													
Length/dim	M6	M8	M10	M12	M16													
25	■	■																
30	■	■																
35	■	■	■															
40	■	■	■	■														
45	■	■	■	■														
50	■	■	■	■	■													
55	■	■	■	■														
60	■	■	■	■	■													
65				■	■													
70	■	■	■	■	■													
75		■	■	■														
80	■	■	■	■	■													
90	■	■	■	■	■													
100	■	■	■	■	■													
110	■	■	■	■	■													
120	■	■	■	■	■													
130		■	■	■	■													
140		■	■	■	■													
150		■	■	■	■													
160				■	■													
170				■	■													
180				■	■													
190				■														
200		■	■	■	■													
300					■													

[CLICK HERE TO RETURN TO THE CONTENTS PAGE](#)



+ 37 064 411 786



Inquiry@invayear.com

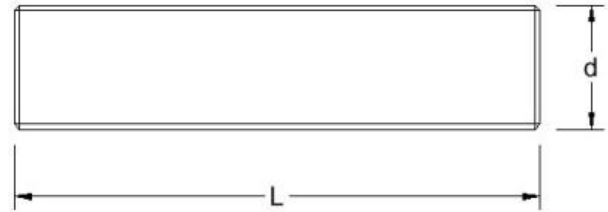

www.invayear.com

 Material grades: **A2**

L	1000	1000	1000	1000	1000	1000	1000											
Pitch	1.00	1.25	1.50	1.75	2.00	2.50	3.00											
Length/dim	M6	M8	M10	M12	M16	M20	M24											
IMTR	■	■	■	■	■	■	■											

[CLICK HERE TO RETURN TO THE CONTENTS PAGE](#)



+ 37 064 411 786

Inquiry@invayear.com

www.invayear.com

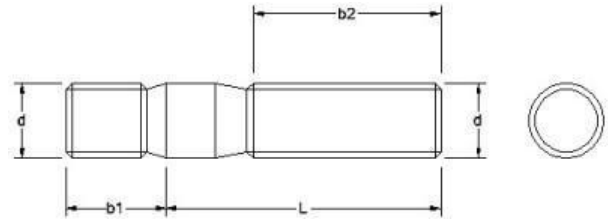
DOUBLE END STUDS DIN 938

Material grades: A2: ■ A4: ◆

b1	6	8	10	12	16	20	24										
b2	18	22	26	30	38	46	54										
Pitch	1.00	1.25	1.50	1.75	2.00	2.50	3.00										
Length/dim	M6	M8	M10	M12	M16	M20	M24										
20	■◆	■◆	■◆	■◆													
25	■◆	■◆	■◆	■◆													
30	■◆	■◆	■◆	■◆	■◆												
35	■◆	■◆	■◆	■◆	■◆	■◆											
40	■◆	■◆	■◆	■◆	■◆	■◆	■◆										
45	■◆	■◆	■◆	■◆	■◆	■◆	■◆										
50		■◆	■◆	■◆	■◆	■◆	■◆	■◆									
55		■◆	■◆	■◆	■◆	■◆	■◆										
60		■◆	■◆	■◆	■◆	■◆	■◆	■◆									
65		■◆	■◆	■◆	■◆	■◆	■◆										
70		■◆	■◆	■◆	■◆	■◆	■◆	■◆									
75		■◆	■◆	■◆	■◆	■◆	■◆										
80		■◆	■◆	■◆	■◆	■◆	■◆	■◆									
85			■◆	■◆	■◆	■◆	■◆										
90		■◆	■◆	■◆	■◆	■◆	■◆	■◆									
95						◆											
100		■◆	■◆	■◆	■◆	■◆	■◆	■◆									
110			■◆	■◆	■◆	■◆	■◆	■◆									
120					■◆	■◆	■◆	■◆									

CLICK HERE TO RETURN TO THE CONTENTS PAGE



+ 37 064 411 786



Inquiry@invayear.com

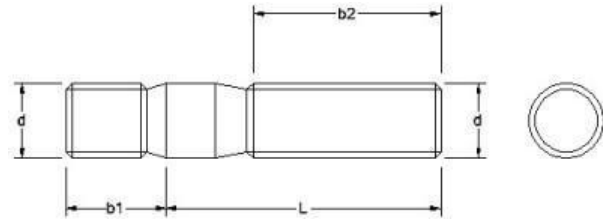

www.invayear.com

DOUBLE END STUDS DIN 939

Material grades: A2: ■ A4: ◆

b1	7.5	10.0	12.0	15.0	20.0	25.0	30.0											
b2	18	22	26	30	38	46	54											
Pitch	1.00	1.25	1.50	1.75	2.00	2.50	3.00											
Length/dim	M6	M8	M10	M12	M16	M20	M24											
20	■◆	■◆	■◆	■◆														
25	■◆	■◆	■◆	■◆														
30	■◆	■◆	■◆	■◆	■◆													
35	■◆	■◆	■◆	■◆	■◆	■◆												
40	■◆	■◆	■◆	■◆	■◆	■◆	■◆											
45	■◆	■◆	■◆	■◆	■◆	■◆	■◆											
50		■◆	■◆	■◆	■◆	■◆	■◆	■◆										
55		■◆	■◆	■◆	■◆	■◆	■◆											
60		■◆	■◆	■◆	■◆	■◆	■◆	■◆										
65		■◆	■◆	■◆	■◆	■◆	■◆											
70		■◆	■◆	■◆	■◆	■◆	■◆	■◆										
75		■◆	■◆	■◆	■◆	■◆	■◆											
80		■◆	■◆	■◆	■◆	■◆	■◆	■◆										
85			■◆	■◆	■◆	■◆	■◆											
90		■◆	■◆	■◆	■◆	■◆	■◆	■◆										
100		■◆	■◆	■◆	■◆	■◆	■◆	■◆										
110			■◆	■◆	■◆	■◆	■◆	■◆										
120					■◆	■◆	■◆											

[CLICK HERE TO RETURN TO THE CONTENTS PAGE](#)

+ 37 064 411 786

Inquiry@invayear.com

www.invayear.com

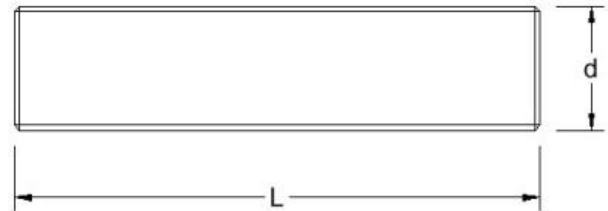
THREADED ROD X 36"

Material grades: A2: ■ A4: ◆

L	36	36	36	36	36	36	36	36	36	36	36	36	36	36	36	36	36
Length/dim	2-56	4-40	5-40	6-32	6-40	8-32	10-24	10-32	12-24	1/4-20	1/4-28	5/16-18	5/16-24	3/8-16	3/8-24	7/16-14	7/16-20
3FT	■◆	■◆	■◆	■◆	■◆	■◆	■◆	■◆	■	■◆	■◆	■◆	■◆	■◆	■◆	■◆	■◆

L	36	36	36	36	36	36	36	36	36	36	36	36					
Length/dim	1/2-13	1/2-20	9/16-12	9/16-18	5/8-11	5/8-18	3/4-10	3/4-16	7/8-9	7/8-14	1-8	1-12					
3FT	■◆	■◆	■◆	■◆	■◆	■◆	■◆	■◆	■◆	■◆	■◆	■◆					

CLICK HERE TO RETURN TO THE CONTENTS PAGE



+ 37 064 411 786



Inquiry@invayear.com

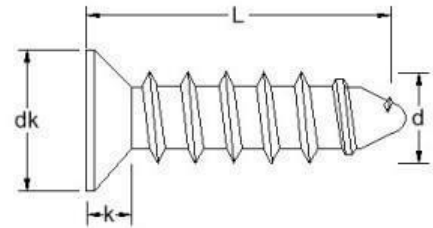
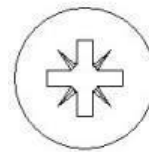

www.invayear.com

CHIPBOARD SCREWS
POZI COUNTERSUNK CHIPBOARD SCREWS FULL THREAD

Material grades: A2: ■ A4: ◆

dk (Max)	6	7	8	9	10	12												
k	1.5	1.75	2	2.25	2.5	3												
Length/dim	3.0	3.5	4.0	4.5	5.0	6.0												
12/12	■◆	■◆	■◆															
13/13		■	■◆															
14/14	■◆	◆	◆															
16/16	■◆	■◆	■◆	■◆														
20/20	■◆	■◆	■◆	■◆	■◆	■◆												
25/25	■◆	■◆	■◆	■◆	■◆	■◆												
30/30	■◆	■◆	■◆	■◆	■◆	■◆												
35/35	■◆	■◆	■◆	■◆	■◆	■◆												
40/40	■◆	■◆	■◆	■◆	■◆	■◆												
45/45	◆	■◆	■◆	■◆	■◆	■◆												
50/50	■◆	■◆	■◆	■◆	■◆	■◆												
55/55			■◆	■◆	■◆	■◆												
60/60			■◆	■◆	■◆	■◆												
65/65			■◆	■◆	■◆	■◆												
70/70			■◆	■◆	■◆	■◆												
75/75			◆															
80/80			■	■◆	■◆	■◆												
90/90					■◆	■◆												
100/100					■◆	■◆												
110/110					■	■												
120/120					■	■◆												
130/130						■												
140/140						■◆												

[CLICK HERE TO RETURN TO THE CONTENTS PAGE](#)



+ 37 064 411 786



Inquiry@invayear.com

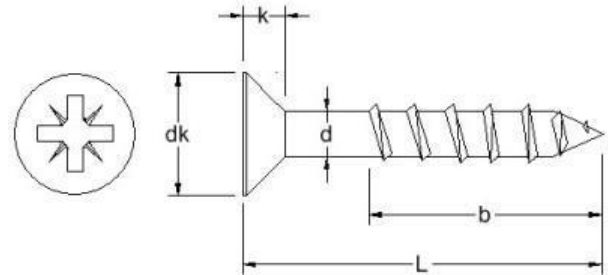

www.invayear.com

POZI COUNTERSUNK CHIPBOARD SCREWS

Material grades: A2: ■ A4: ◆

b (approx)	0.6 x L	0.6 x L	0.6 x L	0.6 x L	0.6 x L	0.6 x L												
dk (Max)	6	7	8	9	10	12												
k	1.5	1.75	2	2.25	2.5	3												
Length/dim	3.0	3.5	4.0	4.5	5.0	6.0												
25	◆	◆	◆	◆	◆													
30	◆	◆	◆	◆	◆													
35	◆	◆	◆	◆	◆													
40	◆	◆	◆	◆	◆	◆												
45	◆		◆	◆	◆													
50	◆	◆	◆	◆	◆	◆												
55			◆	◆	◆													
60			◆	◆	◆	◆												
65					◆													
70			◆	◆	◆	◆												
80			◆	◆	◆	◆												
90				◆	◆	◆												
100				◆	◆	◆												
110					◆	◆												
120					◆	◆												
140						◆												
150						◆												
160							◆											
180								◆										
200									◆									

[CLICK HERE TO RETURN TO THE CONTENTS PAGE](#)



+ 37 064 411 786

Inquiry@invayear.com

www.invayear.com

CHIPBOARD SCREWS

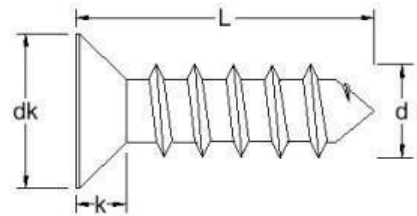
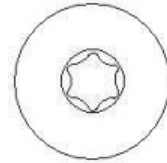
TX COUNTERSUNK CHIPBOARD SCREWS FULL THREAD



Material grades: A2: ■ A4: ◆

dk (Max)	6	7	8	9	10	12												
k	1.5	1.75	2	2.25	2.5	3												
Length/dim	3.0	3.5	4.0	4.5	5.0	6.0												
10/10	■◆																	
12/12	■	■																
13/13	■◆	■◆	■◆															
16/16	■◆	■◆	■◆															
20/20	■◆	■◆	■◆	■◆	■◆													
25/25	■◆	■◆	■◆	■◆	■◆													
30/30	■◆	■◆	■◆	■◆	■◆	■◆												
35/35	■◆	■◆	■◆	■◆	■◆	■◆												
40/40		■◆	■◆	■◆	■◆	■◆												
45/45			■◆	■◆	■◆	■◆												
50/50			■◆	■◆	■◆	■◆												
55/55			■◆	■◆	■◆	■◆												
60/60			■◆	■◆	■◆	■◆												
70/70			■◆	■◆	■◆	■◆												
80/80			■◆	■◆	■◆	■◆												
90/90					■◆	■◆												
100/100					■◆	■◆												

[CLICK HERE TO RETURN TO THE CONTENTS PAGE](#)



+ 37 064 411 786



Inquiry@invayear.com

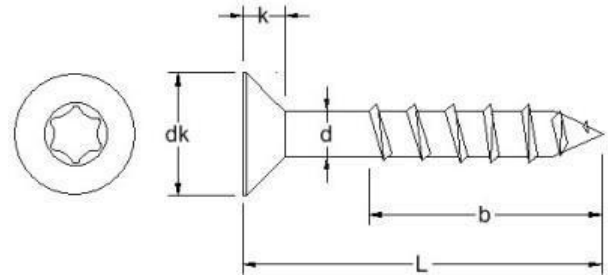

www.invayear.com

TX COUNTERSUNK CHIPBOARD SCREWS

Material grades: A2: ■ A4: ◆

b (approx)	0.6 x L	0.6 x L	0.6 x L	0.6 x L	0.6 x L	0.6 x L	0.6 x L	55-105									
dk (Max)	6	7	8	9	10	12	14	*									
k	1.5	1.75	2	2.25	2.5	3	4	*									
Length/dim	3.0	3.5	4.0	4.5	5.0	6.0	8.0	10									
25	■◆	■◆	■◆	■	■												
30	■◆	■◆	■◆	■◆	■◆												
35	■	■◆	■◆	■◆	■◆												
40	■◆	■◆	■◆	■◆	■◆	■◆											
45		◆	■◆	■◆	■◆	■◆											
50		■◆	■◆	■◆	■◆	■◆											
60			■◆	■◆	■◆	■◆	■◆	■◆									
70			■◆	■◆	■◆	■◆	■◆	■◆									
80				■◆	■◆	■◆	■◆	■◆									
90					■◆	■◆	■◆										
100					■◆	■◆	■◆	■◆									
110						■											
120					■◆	■◆	■◆	■◆									
130						■											
140						■◆	■◆	■◆									
150						■											
160						■◆	■◆	■◆									

[CLICK HERE TO RETURN TO THE CONTENTS PAGE](#)

+ 37 064 411 786

Inquiry@invayear.com

www.invayear.com

CHIPBOARD SCREWS
TX COUNTERSUNK CHIPBOARD SCREWS

Material grades: A2: ■ A4: ◆

b (approx)	0.6 x L	0.6 x L	0.6 x L	0.6 x L	0.6 x L	0.6 x L	0.6 x L	55-105									
dk (Max)	6	7	8	9	10	12	14	*									
k	1.5	1.75	2	2.25	2.5	3	4	*									
Length/dim	3.0	3.5	4.0	4.5	5.0	6.0	8.0	10									
180						■◆	■◆	■◆									
200						■◆	■◆	■◆									
220						■	■◆	■◆									
240						■	■◆	■◆									
260						■	■◆	■◆									
280						■	■◆	■◆									
300						■	■◆	■◆									
320								■									
325							■										
340								■									
350								■									
360								■									
375								■	■								

[CLICK HERE TO RETURN TO THE CONTENTS PAGE](#)



+ 37 064 411 786

Inquiry@invayear.com

www.invayear.com

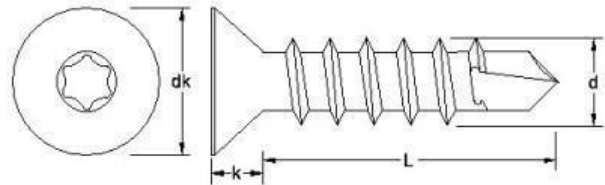
TX COUNTERSUNK SELF DRILL CHIPBOARD SCREWS

 Material grades: **A2**

b (approx)	0.6 x L	0.6 x L	0.6 x L	0.6 x L														
dk (Max)	8	9	10	12														
k	2	2.25	2.5	3														
Length/dim	4.0	4.5	5.0	6.0														
30	■	■																
35	■	■																
40	■	■	■	■														
45	■	■	■	■														
50	■	■	■	■														
55	■	■	■	■														
60	■	■	■	■														
65	■	■	■	■														
70	■	■	■	■														
80	■	■	■	■														
90			■	■														
100			■	■														
120				■														
140				■														
160				■														

CLICK HERE TO RETURN TO THE CONTENTS PAGE



+ 37 064 411 786



Inquiry@invayear.com

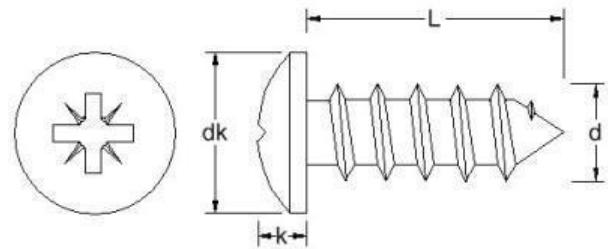

www.invayear.com

CHIPBOARD SCREWS
POZI PAN CHIPBOARD SCREWS FULL THREAD

Material grades: A2: ■ A4: ◆

b (approx)*	0.6 x L																	
dk (Max)	6	7	8	9	10	12												
k	1.6	1.8	2.1	2.9	3.3	3.8												
Length/dim	3.0	3.5	4.0	4.5	5.0	6.0												
10/10	■◆																	
12/12	■◆	■◆	■◆															
13/13			■															
16/16	■◆	■◆	■◆	■														
20/20	■◆	■◆	■◆	■◆	■◆	■◆												
25/25	■◆	■◆	■◆	■◆	■◆	■◆												
30/30	■◆	■◆	■◆	■◆	■◆	■◆												
35/35	■	■◆	■◆	■◆	■◆	■◆												
40/40		■◆	■◆	■◆	■◆	■◆												
45/45		■◆	■◆	■	■	■◆												
50/50		■	■◆	■◆	■◆	■◆												
55/55			■	■	■◆	■												
60/60			■◆	■◆	■◆	■◆												
65/65			■	■	■◆	■												
70/70			■	■	■◆	■◆												
75/75			■	■	■◆	■◆												
80/80					■	■◆												
90/90					■	■◆												
100/100					■	■◆												
110/110						■◆												
120/120						■◆												

[CLICK HERE TO RETURN TO THE CONTENTS PAGE](#)



+ 37 064 411 786



Inquiry@invayear.com

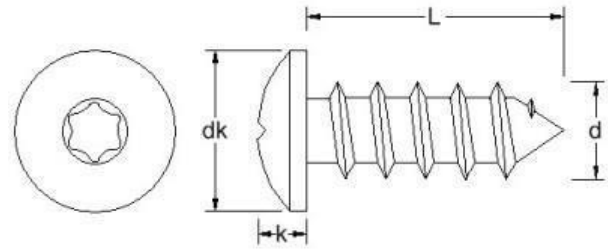

www.invayear.com

TX PAN CHIPBOARD SCREWS FULL THREAD

Material grades: A2: ■

dk (Max)	6	7	8	9	10	12												
k	1.6	1.8	2.1	2.9	3.3	3.8												
Length/dim	3.0	3.5	4.0	4.5	5.0	6.0												
10/10	■																	
12/12	■	■	■															
16/16	■	■	■	■														
20/20	■		■	■	■	■												
25/25	■	■	■	■	■	■												
30/30	■	■	■	■	■	■												
35/35	■	■	■	■	■	■												
40/40		■	■	■	■	■												
45/45		■	■	■	■	■												
50/50		■	■	■	■	■												
55/55					■													
60/60			■	■	■	■												
70/70			■	■	■	■												
80/80					■	■												
90/90					■	■												
100/100					■	■												
110/110						■												
120/120						■												

[CLICK HERE TO RETURN TO THE CONTENTS PAGE](#)

+ 37 064 411 786

Inquiry@invayear.com

www.invayear.com

CHIPBOARD SCREWS
TX PAN CHIPBOARD SCREWS

 Material grades: **A2**

b (approx)*	0.6 x L	0.6 x L	0.6 x L	0.6 x L	0.6 x L													
dk (Max)	7	8	9	10	12													
k	1.8	2.1	2.9	3.3	3.8													
Length/dim	3.5	4.0	4.5	5.0	6.0													
25	■																	
30	■	■	■	■														
35	■	■		■														
40	■	■	■	■	■													
45	■	■	■	■	■													
50	■	■	■	■	■													
60		■	■	■	■													
70		■	■	■	■													
80				■	■													
90				■	■													
100				■	■													
120					■													

[CLICK HERE TO RETURN TO THE CONTENTS PAGE](#)



+ 37 064 411 786



Inquiry@invayear.com

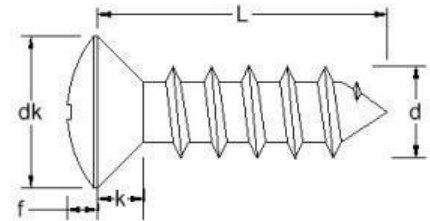
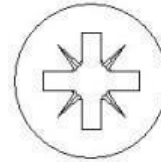

www.invayear.com

POZI RAISED COUNTERSUNK CHIPBOARD SCREWS FULL THREAD

Material grades: A2:■

b (approx)*	0.6 x L	0.6 x L	0.6 x L	0.6 x L	0.6 x L	0.6 x L												
dk (Max)	5.6	6.5	7.5	8.3	9.2	11												
k	1.65	1.93	2.2	2.35	2.5	3												
Length/dim	3.0	3.5	4.0	4.5	5.0	6.0												
12/12	■																	
16/16	■	■	■	■														
20/20	■	■	■	■														
25/25	■	■	■		■	■												
30/30	■	■	■	■	■	■												
35/35	■	■	■	■	■	■												
40/40		■	■	■	■	■												
45/45		■	■	■	■	■												
50/50		■	■	■	■	■												
60/60			■	■	■	■												
65/65				■														
70/70			■	■	■	■												
80/80					■	■												
90/90					■	■												
100/100					■	■												
110/110						■												
120/120						■												

[CLICK HERE TO RETURN TO THE CONTENTS PAGE](#)



+ 37 064 411 786



Inquiry@invayear.com



www.invayear.com

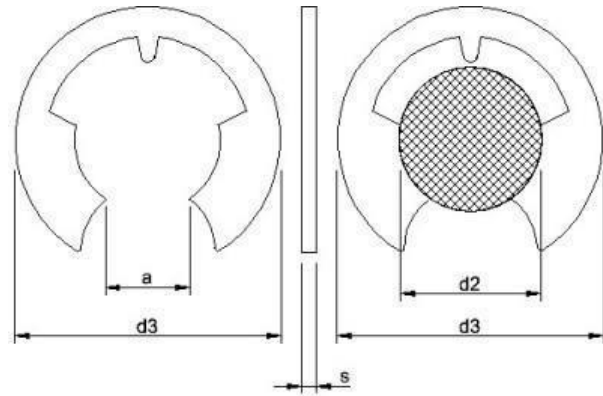

Material grades: A2:■

a	1.01	1.28	1.61	1.94	2.70	3.34	4.11	5.26	5.84	6.52	7.63	8.32	10.45	12.61	15.92	21.88	
d3 (Max)	3.25	4.25	4.8	6.3	7.3	9.3	11.3	12.3	14.3	16.3	18.8	20.4	23.4	29.4	37.6	44.6	
s	0.3	0.4	0.5	0.6	0.6	0.7	0.7	0.7	0.9	1.0	1.1	1.2	1.3	1.5	1.75	2	
Length/dim	1.2MM	1.5MM	1.9MM	2.3MM	3.2MM	4.0MM	5.0MM	6.0MM	7.0MM	8.0MM	9.0MM	10MM	12MM	15MM	19MM	24MM	
	■	■	■	■	■	■	■	■	■	■	■	■	■	■	■	■	

CLICK HERE TO RETURN TO THE CONTENTS PAGE



+ 37 064 411 786



Inquiry@invayear.com

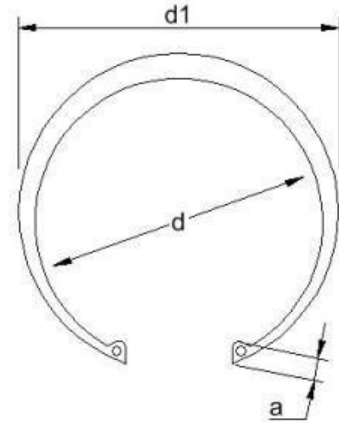
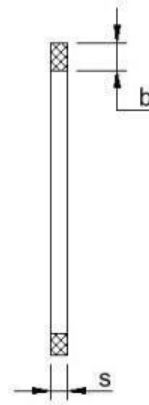

www.invayear.com

INTERNAL CIRCLIPS DIN 472

Material grades: A2:■

a (Max)	2.4	2.5	3.2	3.3	3.4	3.6	3.7	3.7	3.8	3.9	4.1	4.1	4.2	4.2	4.2	4.3	4.4
b	1.1	1.3	1.4	1.5	1.7	1.8	1.9	2	2	2.1	2.2	2.2	2.3	2.5	2.5	2.5	2.6
d1	8.7	9.8	10.8	11.8	13	14.1	15.1	16.2	17.3	18.3	19.5	20.5	21.5	22.5	23.5	24.6	25.9
s	0.8	0.8	1	1	1	1	1	1	1	1	1	1	1	1	1	1	1.2
Length/dim	8	9	10	11	12	13	14	15	16	17	18	19	20	21	22	23	24
	■	■	■	■	■	■	■	■	■	■	■	■	■	■	■	■	■

a (Max)	4.5	4.7	4.7	4.8	4.8	4.8	5.2	5.4	5.4	5.4	5.4	5.4	5.5	5.5	5.6	5.8	5.9
b	2.7	2.8	2.8	2.9	3.0	3.0	3.2	3.2	3.3	3.3	3.4	3.5	3.6	3.7	3.8	3.9	4.0
d1	26.9	27.9	28.9	30.1	31.1	32.1	33.4	34.4	35.5	36.5	37.8	38.8	39.8	40.8	42	43.5	44.5
s	1.2	1.2	1.2	1.2	1.2	1.2	1.2	1.2	1.2	1.5	1.5	1.5	1.5	1.5	1.5	1.75	1.75
Length/dim	25	26	27	28	29	30	31	32	33	34	35	36	37	38	39	40	41
	■	■	■	■	■	■	■	■	■	■	■	■	■	■	■	■	■

CLICK HERE TO RETURN TO THE CONTENTS PAGE



+ 37 064 411 786



Inquiry@invayear.com



www.invayear.com

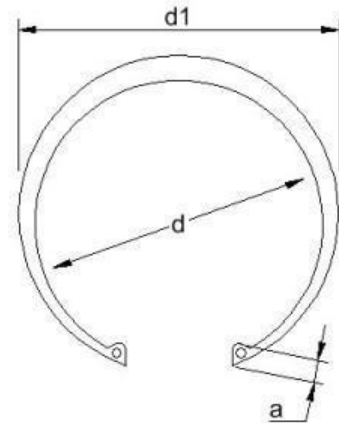
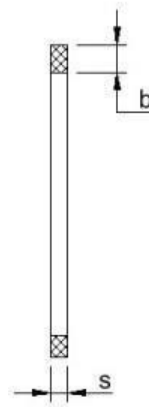

Material grades: A2:■

a (Max)	5.9	5.9	6.0	6.2	6.4	6.4	6.5	6.7	6.8	6.9	7.3	7.3	7.6	7.8	7.8	7.8	7.8
b	4.1	4.2	4.2	4.3	4.4	4.5	4.6	4.7	5	5.2	5.4	5.5	5.8	6.1	6.2	6.4	6.6
dI	45.5	46.5	47.5	48.5	50.5	51.5	54.2	56.2	59.2	62.2	64.2	66.2	69.2	72.5	74.5	76.5	79.5
s	1.75	1.75	1.75	1.75	1.75	1.75	2	2	2	2	2	2	2.5	2.5	2.5	2.5	2.5
Length/dim	42	43	44	45	47	48	50	52	55	58	60	62	65	68	70	72	75
	■	■	■	■	■	■	■	■	■	■	■	■	■	■	■	■	■

a (Max)	8.5	8.6	8.6	8.8	9.2												
b	7.0	7.2	7.6	8.1	8.7												
dI	85.5	90.5	95.5	100.5	105.5												
s	2.5	3	3	3	3												
Length/dim	80	85	90	95	100	105	110	120	130	140	150						
	■	■	■	■	■	■	■	■	■	■	■						

[CLICK HERE TO RETURN TO THE CONTENTS PAGE](#)



+ 37 064 411 786



Inquiry@invayear.com

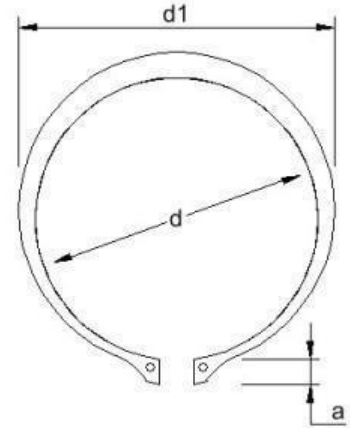
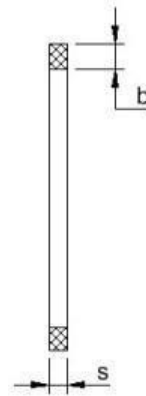

www.invayear.com

EXTERNAL CIRCLIPS DIN 471

Material grades: A2:■

a (Max)	1.9	2.2	2.5	2.7	3.1	3.2	3.3	3.3	3.3	3.3	3.4	3.5	3.6	3.7	3.8	3.9	3.9
b	0.8	0.9	1.1	1.3	1.4	1.5	1.7	1.8	1.8	1.8	1.9	2.1	2.2	2.2	2.3	2.5	2.5
d	2.7	3.7	4.7	5.6	6.5	7.4	8.4	9.3	10.2	11	11.9	12.9	13.8	14.7	15.7	16.5	17.5
s	0.4	0.4	0.6	0.7	0.8	0.8	1	1	1	1	1	1	1	1	1	1.2	1.2
Length/dim	3	4	5	6	7	8	9	10	11	12	13	14	15	16	17	18	19
	■	■	■	■	■	■	■	■	■	■	■	■	■	■	■	■	■

a (Max)	4	4.1	4.2	4.3	4.4	4.4	4.4	4.6	4.7	4.8	5	5.2	5.4	5.6	5.6	5.8	5.9
b	2.6	2.7	2.8	2.9	3	3	3.1	3.1	3.2	3.4	3.5	3.6	3.8	3.9	4	4.2	4.3
d	18.5	19.5	20.5	21.4	22.2	23.2	24.2	25.1	25.9	26.9	27.9	29.6	31.5	32.2	33.2	35.2	36
s	1.2	1.2	1.2	1.2	1.2	1.2	1.2	1.2	1.5	1.5	1.5	1.5	1.5	1.5	1.75	1.75	1.75
Length/dim	20	21	22	23	24	25	26	27	28	29	30	32	34	35	36	38	39
	■	■	■	■	■	■	■	■	■	■	■	■	■	■	■	■	■

a (Max)	6	6.5	6.7	6.9	6.9	7	7.2	7.4	7.8	8.1	8.4	8.6	8.7	8.8	9.4	9.6	
b	4.4	4.5	4.7	5	5.1	5.2	5.4	5.8	6.3	6.6	7.0	7.4	7.8	8.2	8.6	9.0	
d	36.5	38.5	41.5	44.5	45.8	47.8	50.8	55.8	60.8	65.5	70.5	74.5	79.5	84.5	89.5	94.5	
s	1.75	1.75	1.75	1.75	2	2	2	2	2.5	2.5	2.5	2.5	3	3	3	3	
Length/dim	40	42	45	48	50	52	55	60	65	70	75	80	85	90	95	100	
	■	■	■	■	■	■	■	■	■	■	■	■	■	■	■	■	

CLICK HERE TO RETURN TO THE CONTENTS PAGE



+ 37 064 411 786



Inquiry@invayear.com



www.invayear.com

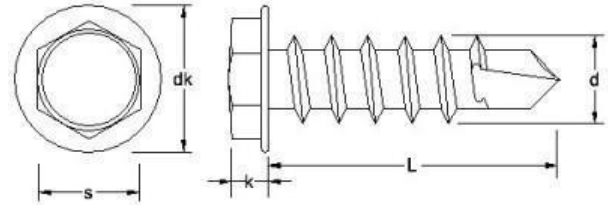

Material grades: A2: ■

dk (Max)	8.3	8.3	8.8	10.5	11	13.5													
k (Max)	3.4	3.4	4.1	4.3	5.4	5.9													
s	5.5	5.5	7	8	8	10													
Length/dim	3.5	3.9	4.2	4.8	5.5	6.3													
9.5	■																		
13	■	■	■	■															
16	■	■	■	■	■	■													
19	■	■	■	■	■	■													
22	■	■	■	■	■	■													
25	■	■	■	■	■	■													
28					■														
30					■														
32		■	■	■	■	■													
35				■	■														
38		■	■	■	■	■													
45				■	■	■													
50			■	■	■	■													
60				■	■	■													
70				■	■														
75																			
80					■														
90				■	■	■													
100					■	■													
110					■	■													
120					■														
150																			

[CLICK HERE TO RETURN TO THE CONTENTS PAGE](#)



+ 37 064 411 786



Inquiry@invayear.com

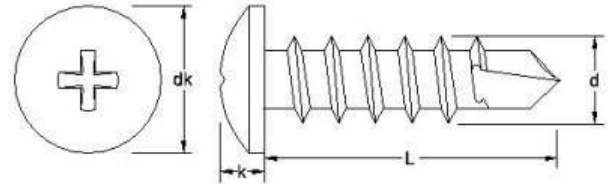

www.invayear.com

POZI PAN SELF DRILLING DIN 7504N Z

Material grades: A2:■

dk (Max)	5.5	6.9	7.5	8.2	9.5	11											
k (Max)	2.4	2.6	2.8	3.1	3.7	4											
Length/dim	2.9	3.5	3.9	4.2	4.8	5.5											
9.5	■	■															
13	■	■	■	■	■												
16		■	■	■	■												
19		■	■	■	■	■											
22		■	■	■	■												
25		■	■	■	■	■											
32			■	■	■	■											
38				■	■	■											
45					■	■											
50					■	■											
60					■	■											
70					■												

[CLICK HERE TO RETURN TO THE CONTENTS PAGE](#)

+ 37 064 411 786

Inquiry@invayear.com

www.invayear.com

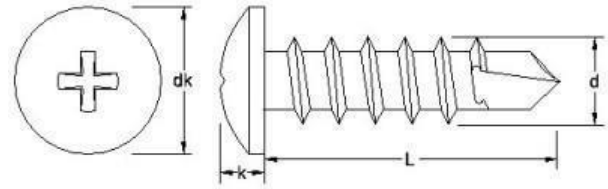
DIN 7504N H
PHILLIPS PAN SELF DRILLING DIN 7504N H

Material grades: A2:■

dk (Max)	5.5	6.9	7.5	8.2	9.5													
k (Max)	2.4	2.6	2.8	3.1	3.7													
Length/dim	2.9	3.5	3.9	4.2	4.8													
9.5	■																	
13	■	■	■	■	■													
16		■	■	■	■													
19		■	■	■	■													
22		■	■	■	■													
25		■	■	■	■													
32			■	■	■													
38			■	■	■													
45					■													
50					■													
60					■													
70					■													

[CLICK HERE TO RETURN TO THE CONTENTS PAGE](#)

+ 37 064 411 786

Inquiry@invayear.com

www.invayear.com

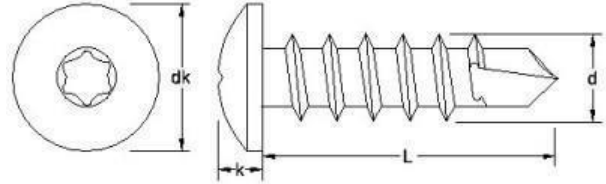
TX PAN SELF DRILLING DIN 7504N TX

 Material grades: **A2**

dk (Max)	6.9	7.5	8.2	9.5	12												
k (Max)	2.6	2.8	3.05	3.55	4.00												
Length/dim	3.5	3.9	4.2	4.8	5.5												
9.5	■																
13	■	■	■	■													
16	■	■	■	■													
19	■	■	■	■	■												
22	■	■	■	■													
25	■	■	■	■	■												
32		■	■	■	■												
38		■	■	■	■												
45				■	■												
50				■	■												
60				■	■												
70				■													

[CLICK HERE TO RETURN TO THE CONTENTS PAGE](#)



+ 37 064 411 786

Inquiry@invayear.com

www.invayear.com

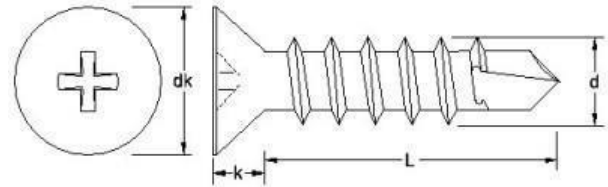

Material grades: A2:■

dk (Max)	7	7.5	8	9.5	10.3													
k (Max)	2.6	2.8	3.1	3.7	4													
Length/dim	3.5	3.9	4.2	4.8	5.5													
13	■	■	■	■														
16	■	■	■	■														
19	■	■	■	■	■													
22	■	■	■	■														
25	■	■	■	■	■													
32		■	■	■	■													
38		■	■	■	■													
45				■	■													
50				■	■													
60					■													

[CLICK HERE TO RETURN TO THE CONTENTS PAGE](#)



+ 37 064 411 786

Inquiry@invayear.com

www.invayear.com

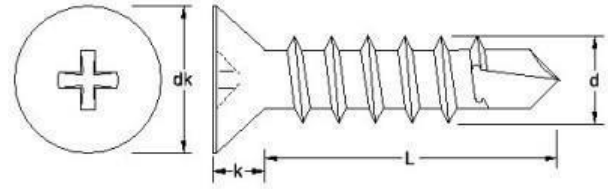
PHILLIPS COUNTERSUNK SELF DRILLING DIN 7504P H

Material grades: A2:■

dk (Max)	7	7.5	8	9.5														
k (Max)	2.6	2.9	3.1	3.7														
Length/dim	3.5	3.9	4.2	4.8														
13	■	■	■	■														
16	■	■	■	■														
19	■	■	■	■														
22	■	■	■	■														
25	■	■	■	■														
32		■	■	■														
38		■	■	■														
45				■														
50				■														

[CLICK HERE TO RETURN TO THE CONTENTS PAGE](#)

+ 37 064 411 786

Inquiry@invayear.com

www.invayear.com

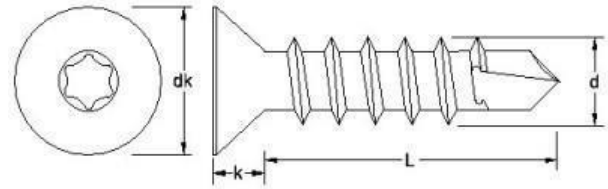
DIN 7504P TX
TX COUNTERSUNK SELF DRILLING DIN 7504P TX

Material grades: A2: ■

dk (Max)	7.3	7.5	8.4	9.3	10.3													
k (Max)	2.1	2.3	2.5	3	3.4													
Length/dim	3.5	3.9	4.2	4.8	5.5													
13	■	■	■	■														
16	■	■	■	■														
19	■	■	■	■	■													
22	■	■	■	■														
25	■	■	■	■	■													
32		■	■	■	■													
38		■	■	■	■													
45				■	■													
50				■	■													
60					■													

[CLICK HERE TO RETURN TO THE CONTENTS PAGE](#)



+ 37 064 411 786



Inquiry@invayear.com

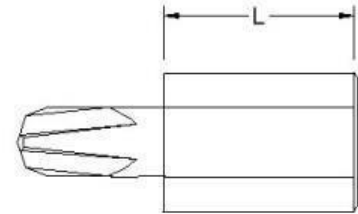
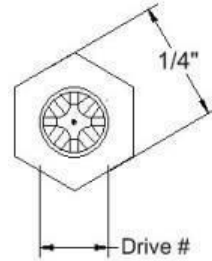

www.invayear.com

POZI

A/F	1/4	1/4	1/4	1/4	1/4														
L	25	25	25	25	25														
Length/dim	NO.0	NO.1	NO.2	NO.3	NO.4														
	■	■	■	■	■														

CLICK HERE TO RETURN TO THE CONTENTS PAGE



+ 37 064 411 786



Inquiry@invayear.com

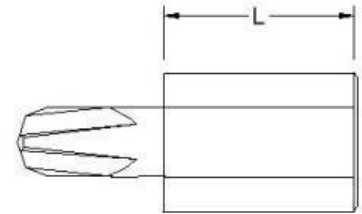
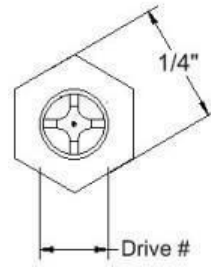

www.invayear.com

DRIVE BITS
PHILLIPS

A/F	1/4	1/4	1/4	1/4	1/4														
L	25	25	25	25	25														
Length/dim	NO.0	NO.1	NO.2	NO.3	NO.4														
	■	■	■	■	■														

CLICK HERE TO RETURN TO THE CONTENTS PAGE



+ 37 064 411 786



Inquiry@invayear.com

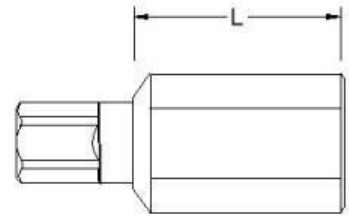
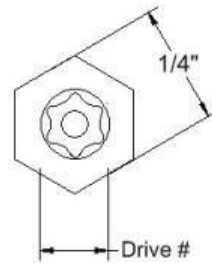

www.invayear.com

PIN TX

A/F	1/4	1/4	1/4	1/4	1/4	1/4	1/4	1/4										
L	25	25	25	25	25	25	25	25										
Length/dim	TX10	TX15	TX20	TX25	TX27	TX30	TX40	TX45										
	■	■	■	■	■	■	■	■										

[CLICK HERE TO RETURN TO THE CONTENTS PAGE](#)



+ 37 064 411 786



Inquiry@invayear.com

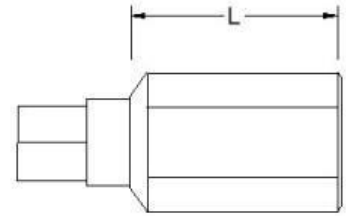
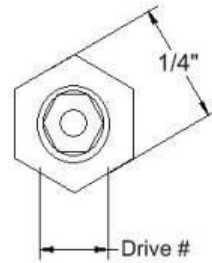

www.invayear.com

DRIVE BITS
PIN HEX

A/F	1/4	1/4	1/4	1/4	1/4	1/4													
L	25	25	25	25	25	25													
Length/dim	HEX20	HEX30	HEX40	HEX50	HEX60	HEX80													
	■	■	■	■	■	■													

[CLICK HERE TO RETURN TO THE CONTENTS PAGE](#)



+ 37 064 411 786



Inquiry@invayear.com

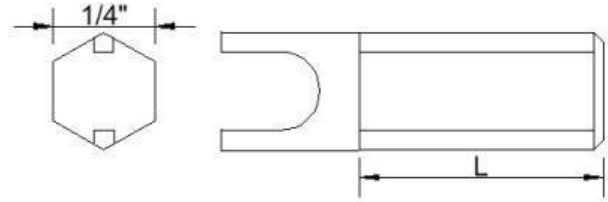

www.invayear.com

DRIVE BITS
2HOLE

A/F	1/4	1/4	1/4	1/4	1/4	1/4													
L	25	25	25	25	25	25													
Length/dim	TH3	TH4	TH5	TH6	TH7	TH8													
	■	■	■	■	■	■													

[CLICK HERE TO RETURN TO THE CONTENTS PAGE](#)



+ 37 064 411 786



Inquiry@invayear.com

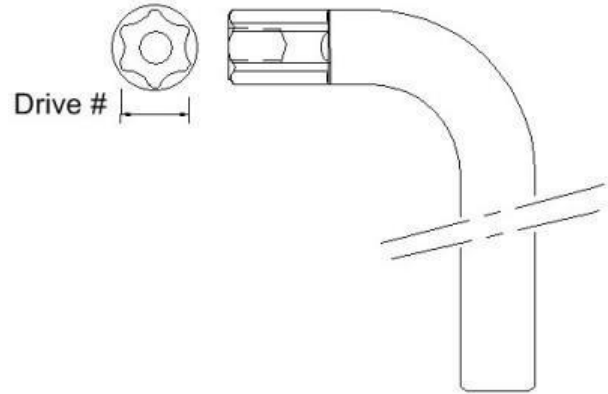

www.invayear.com

PIN TX KEY WRENCH

A/F	1/4	1/4	1/4	1/4	1/4	1/4	1/4	1/4									
Length/dim	TX10	TX15	TX20	TX25	TX27	TX30	TX40	TX45									
	■	■	■	■	■	■	■	■									

[CLICK HERE TO RETURN TO THE CONTENTS PAGE](#)



+ 37 064 411 786



Inquiry@invayear.com



www.invayear.com

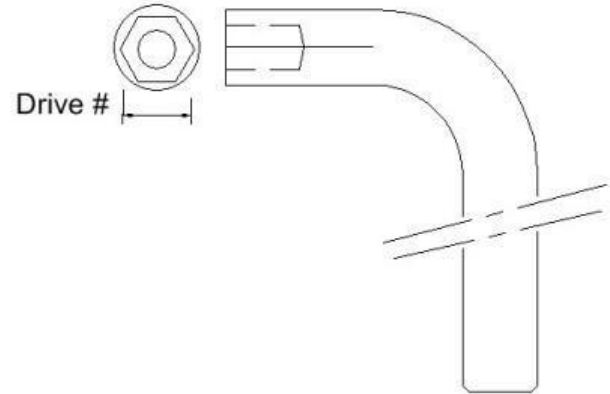

A/F	1/4	1/4	1/4	1/4	1/4	1/4											
Length/dim	HEX20	HEX30	HEX40	HEX50	HEX60	HEX80											
	■	■	■	■	■	■											

CLICK HERE TO RETURN TO THE CONTENTS PAGE



+ 37 064 411 786



Inquiry@invayear.com

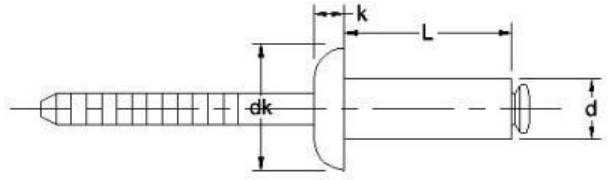

www.invayear.com

DOME RIVETS ISO 15983

Material grades: A2: ■ A4: ◆

dk (Max)	5	6.3	6.7	8.4	10.1	10.5	12	13									
k	0.55	1.3	1.3	1.7	2	2.1	2.5	2.6									
Shear	1000	1800	1900	2700	4000	4700	5700	6500									
Tensile	1500	2200	2500	3500	5000	5800	7500	8850									
Length/dim	2.4	3.0	3.2	4.0	4.8	5.0	6.0	6.4									
4	■																
6	■	◆	◆	◆	◆												
8	■	◆	◆	◆	◆	◆	■										
10		◆	◆	◆	◆	◆	■	■									
12		◆	◆	◆	◆	◆	■	◆									
14		◆	◆	◆	◆	◆	■	◆									
15								■									
16		◆	◆	◆	◆	◆	■	◆									
18			◆	◆	◆	◆	■	◆									
20				◆	◆	◆	■	◆									
22							■	■									
24					◆	■											
25				◆	◆	◆	■	◆									
26					■	■											
30					◆	◆	■	■									
35					■	■	■	■									
40					■	◆	■	■									

[CLICK HERE TO RETURN TO THE CONTENTS PAGE](#)



+ 37 064 411 786



Inquiry@invayear.com



www.invayear.com

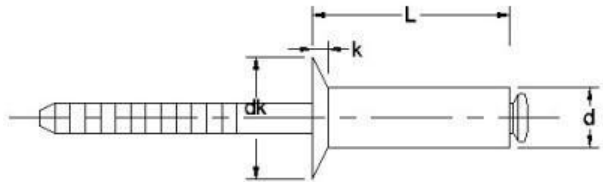

Material grades: A2: ■

dk (Max)	6.3	6.7	8.4	10.1	10.5											
k	1.3	1.3	1.7	2	2.1											
Shear	1800	1900	2700	4000	4700											
Tensile	2200	2500	3500	5000	5800											
Length/dim	3.0	3.2	4.0	4.8	5.0											
6	■	■														
8	■	■	■	■	■											
10	■	■	■	■	■											
12	■	■	■	■	■											
14			■	■	■											
16			■	■	■											
18			■	■	■											
20			■	■	■											
21				■												
25				■	■											
30				■	■											

[CLICK HERE TO RETURN TO THE CONTENTS PAGE](#)



+ 37 064 411 786



Inquiry@invayear.com

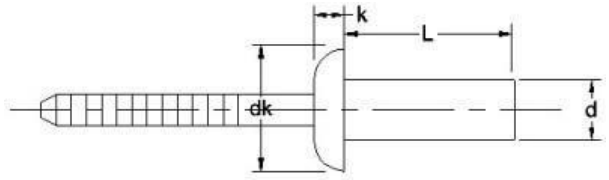

www.invayear.com

SEALED DOME RIVETS ISO 16585

Material grades: A2: ■

dk (Max)	6.7	8.4	10.1	13.4														
k	1.3	1.7	2	2.7														
Shear	2000	3000	4000	6000														
Tensile	2200	3500	4400	8000														
Length/dim	3.2	4.0	4.8	6.4														
6	■	■																
8	■	■	■															
9.5	■	■	■															
10	■	■	■															
12	■	■	■	■														
14	■	■	■	■														
16		■	■	■														
20			■	■														

[CLICK HERE TO RETURN TO THE CONTENTS PAGE](#)



+ 37 064 411 786



Inquiry@invayear.com

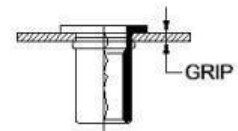
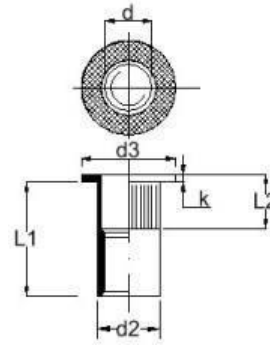

www.invayear.com

FLAT HEAD KNURLED INSERT NUT

 Material grades: **A2**

d2	4.9	5.9	5.9	6.9	6.9	8.9	8.9	10.9	10.9	12.9	12.9	14.9						
d3	7	9	9	10	10	13	13	16	16	19	19	23						
k	0.9	1	1	1	1	1.5	1.5	1.5	1.5	2	2	2						
L1	10	10	11.5	12	15	14.5	16	16	18.5	17	22	23						
L2	5.5	5.5	7.5	6.0	8.0	8.0	10	8.5	11	10	13	12						
Shear	1760	3920	3920	4510	4510	4900	4900	6860	6860	7840	7840	9800						
Tensile	5390	6860	6860	11760	11760	18630	18630	27450	27450	29410	29410	52950						
Length/d	M3	M4	M4	M5	M5	M6	M6	M8	M8	M10	M10	M12						
10	■	■																
11.5			■															
12				■														
14.5					■													
15						■												
16							■		■									
17											■							
18.5											■							
22												■						
23													■					

CLICK HERE TO RETURN TO THE CONTENTS PAGE



+ 37 064 411 786



Inquiry@invayear.com

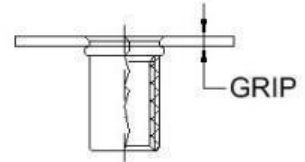
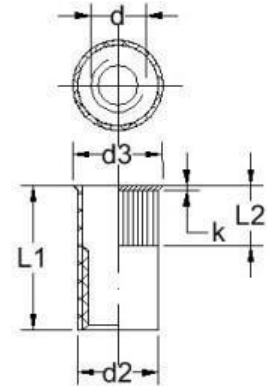

www.invayear.com

COUNTERSUNK KNURLED INSERT NUT

Material grades: A2: ■

d2	5.9	6.9	8.9	10.9	12.9															
d3	9	10	12	14	15															
k	1.5	1.5	1.5	1.5	1.5															
L1	11.5	13.5	16.0	19.0	21.0															
L2	4.0	5.0	5.5	5.5	5.5															
Shear	3720	4020	5490	7640	8040															
Tensile	10100	11760	20590	27450	32360															
Length/dim	M4	M5	M6	M8	M10															
11.5	■																			
13.5		■																		
16			■																	
19				■																
21					■															

[CLICK HERE TO RETURN TO THE CONTENTS PAGE](#)



+ 37 064 411 786



Inquiry@invayear.com

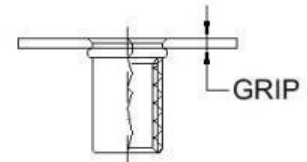
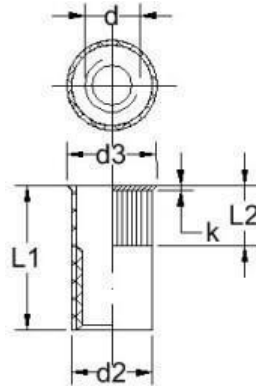

www.invayear.com

RIVETS
REDUCED CSK KNURLED INSERT NUT

Material grades: A2: ■

d2	5.9	6.9	8.9	10.9	12.9													
d3	7	8	10	12	14.5													
k	1	1	1	1	1													
L1	10	11.5	14	15.5	19.5													
L2	5.5	5.5	6.5	7.5	9													
Shear	2940	4020	5190	5390	5880													
Tensile	6860	11760	18630	25490	34320													
Length/dim	M4	M5	M6	M8	M10													
10	■																	
11.5		■																
14			■															
15.5				■														
19.5					■													

[CLICK HERE TO RETURN TO THE CONTENTS PAGE](#)

+ 37 064 411 786

Inquiry@invayear.com

www.invayear.com

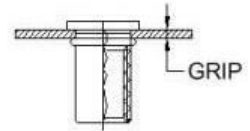
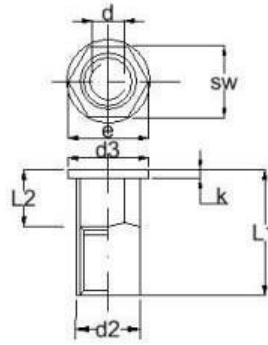
FLAT HEAD HALF HEX INSERT NUT

Material grades: A2: ■

d2	6	7	9	11	12.9														
d3	9.3	10.3	12.3	14.3	16.3														
k	1	1	1.5	1.5	2														
L1	11.5	13.5	15.5	17.5	22														
L2	6	7.5	8	8.5	9.7														
Shear	2640	3620	4700	6860	8620														
SW	6	7	9	11	13														
Tensile	9800	12740	21570	37260	47070														
Length/dim	M4	M5	M6	M8	M10														
11.5	■																		
13.5		■																	
15.5			■																
17.5				■															
22					■														

[CLICK HERE TO RETURN TO THE CONTENTS PAGE](#)



+ 37 064 411 786



Inquiry@invayear.com



www.invayear.com

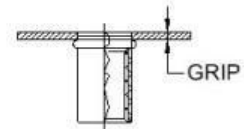
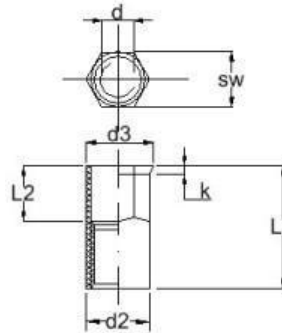

Material grades: A2: ■

d2	6	7	9	11	12.9														
d3	7	8	10	12	14														
k	0.6	0.6	0.6	0.6	0.6														
L1	12	14	16	17	20.5														
L2	6	7.5	8	8.5	9														
Shear	2940	3820	3430	4900	5000														
SW	6	7	9	11	13														
Tensile	8230	11760	21570	24510	47070														
Length/dim	M4	M5	M6	M8	M10														
12	■																		
14		■																	
16			■																
17				■															
20.5					■														

[CLICK HERE TO RETURN TO THE CONTENTS PAGE](#)

+ 37 064 411 786

Inquiry@invayear.com

www.invayear.com

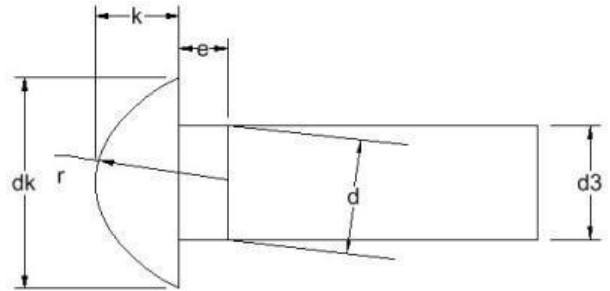
ROUND HEAD SOLID RIVETS DIN 660

Material grades: A2: ■ A4: ◆

d3	1.87	2.87	3.87	4.82	5.82													
dk	3.5	5.2	7	8.8	10.5													
e	1.0	1.5	2.0	2.5	3.0													
k	1.2	1.8	2.4	3.0	3.6													
r	1.9	2.8	3.8	4.6	5.7													
Length/dim	2	3	4	5	6													
6	◆	◆	◆	◆														
8	◆	◆	◆	◆														
10	◆	◆	◆	◆	◆													
12	◆	◆	◆	◆	◆	◆												
14	◆	◆	◆	◆	◆	◆												
16	◆	◆	◆	◆	◆	◆												
18	◆	◆	◆	◆	◆	◆												
20	◆	◆	◆	◆	◆	◆												
22	◆	◆	◆	◆	◆	◆												
25	◆	◆	◆	◆	◆	◆												
28			◆	◆	◆	◆												
30			◆	◆	◆	◆												
35			◆	◆	◆	◆												
40				◆	◆	◆												
45					◆	◆												
50					◆	◆												

CLICK HERE TO RETURN TO THE CONTENTS PAGE



+ 37 064 411 786



Inquiry@invayear.com



www.invayear.com

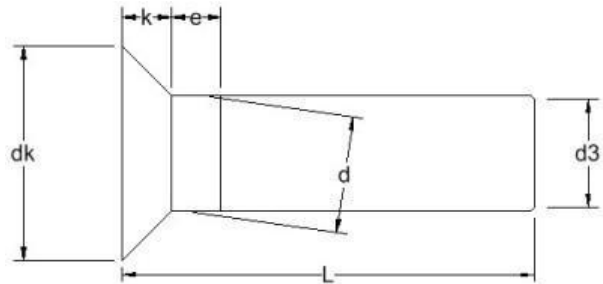

Material grades: A2: ■

d3	1.87	2.87	3.87	4.82	5.82													
dk	3.5	5.2	7	8.8	10.5													
e	1.0	1.5	2.0	2.5	3.0													
k	1.0	1.4	2.0	2.5	3.0													
Length/dim	2	3	4	5	6													
6	■	■	■															
8	■	■	■	■														
10	■	■	■	■	■													
12	■	■	■	■	■													
14	■	■	■	■	■													
16	■	■	■	■	■													
18	■	■	■	■	■													
20	■	■	■	■	■													
22	■	■	■	■	■													
25	■	■	■	■	■													
28			■	■	■													
30			■	■	■													
35			■	■	■													
40				■	■													
45					■													
50					■													

[CLICK HERE TO RETURN TO THE CONTENTS PAGE](#)



+ 37 064 411 786



Inquiry@invayear.com

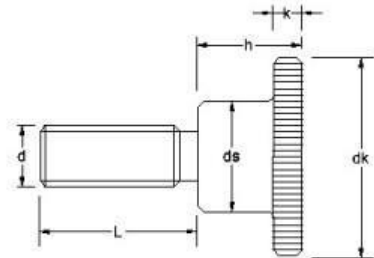
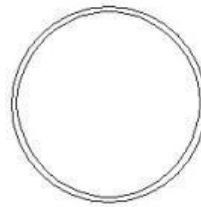

www.invayear.com

KNURLED THUMB SCREWS DIN 464

Material grades: A2:■

dk	12	16	20	24	30	36													
ds	6	8	10	12	16	20													
h	7.5	9.5	11.5	15.0	18.0	23.0													
k	2.5	3.5	4.0	5.0	6.0	8.0													
Pitch	0.5	0.7	0.8	1.0	1.25	1.5													
Length/dim	M3	M4	M5	M6	M8	M10													
4	■																		
5	■	■																	
6	■	■	■																
8	■	■	■	■															
10	■	■	■	■															
12	■	■	■	■	■														
16	■	■	■	■	■	■													
20	■	■	■	■	■	■	■												
25		■	■	■	■	■	■												
30		■		■	■	■	■												

[CLICK HERE TO RETURN TO THE CONTENTS PAGE](#)



+ 37 064 411 786



Inquiry@invayear.com



www.invayear.com

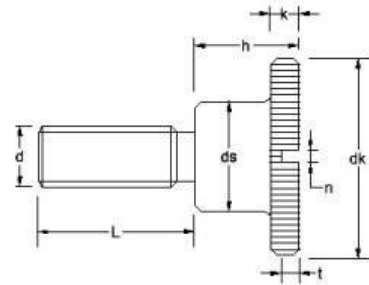
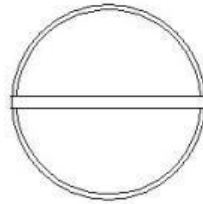

Material grades: A2:■

dk	12	16	20	24															
ds	6	8	10	12															
h	7.5	9.5	11.5	15.0															
k	2.5	3.5	4.0	5.0															
n	0.8	1.0	1.2	1.6															
Pitch	0.5	0.7	0.8	1.0															
t (Min)	1.8	2.2	2.8	3.5															
Length/dim	M3	M4	M5	M6															
6	■	■	■																
8	■	■	■																
10	■	■	■	■															
12	■	■	■	■															
16	■	■	■	■															
20	■	■	■	■															

CLICK HERE TO RETURN TO THE CONTENTS PAGE



+ 37 064 411 786



Inquiry@invayear.com

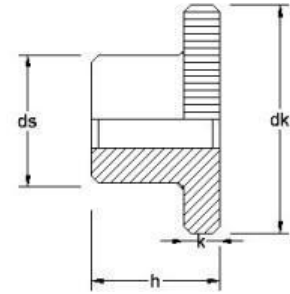
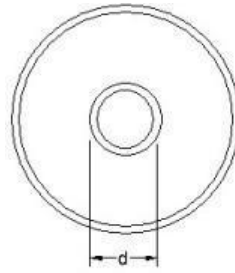

www.invayear.com

KNURLED THUMB NUTS HIGH TYPE DIN 466

Material grades: A2:■

dk	9	11	12	16	20	24	30	36									
ds	4.5	5	6	8	10	12	16	20									
h	5.3	6.5	7.5	9.5	11.5	15.0	18.0	23.0									
k	2.0	2.5	2.5	3.5	4.0	5.0	6.0	8.0									
Pitch	0.40	0.45	0.50	0.70	0.80	1.00	1.25	1.50									
Length/dim	M2	M2.5	M3	M4	M5	M6	M8	M10									
	■	■	■	■	■	■	■	■									

[CLICK HERE TO RETURN TO THE CONTENTS PAGE](#)

+ 37 064 411 786

Inquiry@invayear.com

www.invayear.com

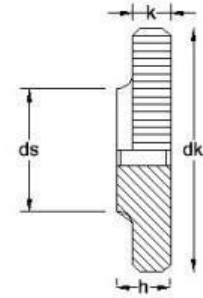
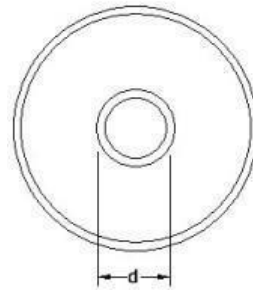

Material grades: A2: ■

dk	11	12	16	20	24	30	36											
ds	5	6	8	10	12	16	20											
h	3	3	4	5	6	8	10											
k	2.5	2.5	3.5	4.0	5.0	6.0	8.0											
Pitch	0.45	0.50	0.70	0.80	1.00	1.25	1.50											
Length/dim	M2.5	M3	M4	M5	M6	M8	M10											
	■	■	■	■	■	■	■											

[CLICK HERE TO RETURN TO THE CONTENTS PAGE](#)



+ 37 064 411 786

Inquiry@invayear.com

www.invayear.com

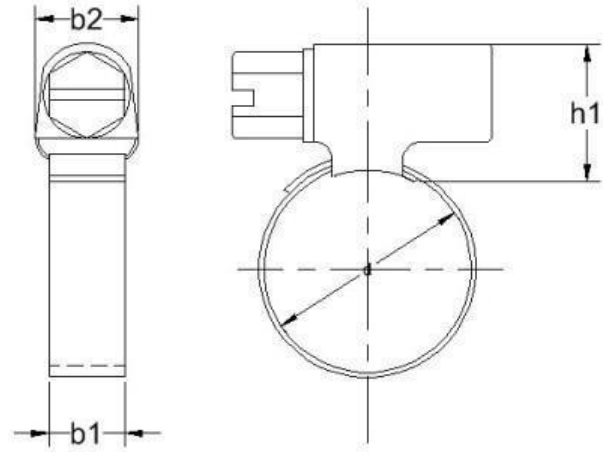
HOSE CLAMPS WORM GEAR DRIVE DIN 3017

Material grades: A2: ■ A4: ◆

b1	9	9	12	9	12	9	12	9	12	9	12	9	12	9	12	9	12
b2	14	14	20	14	20	14	20	14	20	14	20	14	20	14	20	14	20
h1	14	14	16	14	16	14	16	14	16	14	16	14	16	14	46	14	16
Length/dim	10-16/9	12-22/9	12-22/12	16-27/9	16-27/12	20-32/9	20-32/12	25-40/9	25-40/12	30-45/9	30-45/12	35-50/9	35-50/12	40-60/9	40-60/12	50-70/9	50-70/12
	■◆	■◆	■◆	■◆	■◆	■◆	■◆	■◆	■◆	■◆	■◆	■◆	■◆	■◆	■◆	■◆	■◆

b1	12	12	12	12	12	12	12	12	12								
b2	20	20	20	20	20	20	20	20	20								
h1	16	16	16	16	16	16	16	16	16								
Length/dim	60-80/12	70-90/12	80-100/12	90-110/12	100-120/12	110-130/12	120-140/12	130-150/12	140-160/12								
	■◆	■◆	■◆	■◆	■◆	■◆	■◆	■◆	■◆								

CLICK HERE TO RETURN TO THE CONTENTS PAGE



+ 37 064 411 786



Inquiry@invayear.com



www.invayear.com

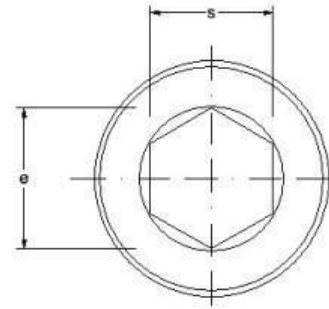
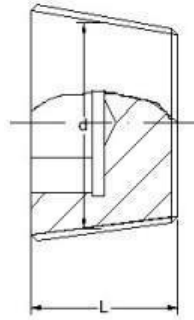

Material grades: A2: ■ A4: ◆

e	4.6	5.7	6.9	8.0	9.2	9.2	11.4	11.4	13.7	13.7	13.7	19.4						
L	8	8	10	10	10	10	10	10	12	12	12	12						
s	SW4	SW5	SW6	SW7	SW8	SW8	SW10	SW10	SW12	SW12	SW12	SW17						
Length/dim	M8	M10	M12	M14	M16	M18	M20	M22	M24	M26	M27	M30						
1.0	■◆	■◆																
1.5			■◆	■◆	■◆	■◆	■◆	■◆	■◆	■◆		■◆						
2.0											■◆	■◆						

CLICK HERE TO RETURN TO THE CONTENTS PAGE



+ 37 064 411 786



Inquiry@invayear.com

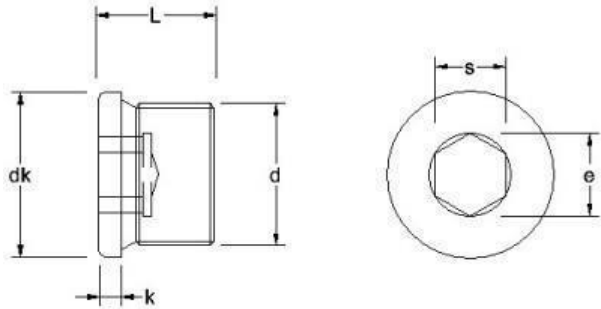

www.invayear.com

SOCKET PIPE PLUGS WITH COLLAR DIN 908

Material grades: A2: ■ A4: ◆

dk	14	17	19	21	23	25	27	29	31	32	36						
e	5.7	6.9	6.9	9.2	9.2	11.4	11.4	13.7	13.7	13.7	19.4						
k	3	3	3	3	4	4	4	4	4	4	4						
L	11	15	15	15	16	18	18	18	20	20	20						
s	SW5	SW6	SW6	SW8	SW8	SW10	SW10	SW12	SW12	SW12	SW17						
Length/dim	M10	M12	M14	M16	M18	M20	M22	M24	M26	M27	M30						
1.0	■ ◆																
1.5		■ ◆	■ ◆	■ ◆	■ ◆	■ ◆	■ ◆	■ ◆	■ ◆		■ ◆						
2.0										■ ◆	■ ◆						

[CLICK HERE TO RETURN TO THE CONTENTS PAGE](#)



+ 37 064 411 786

Inquiry@invayear.com

www.invayear.com

SHOULDER SCREWS

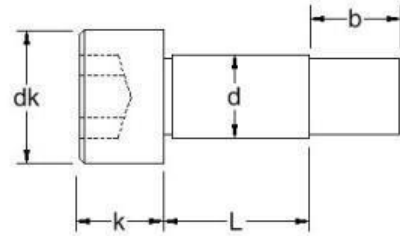
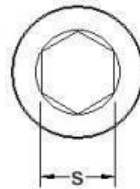
SOCKET SHOULDER SCREWS



Material grades: A2: ■ 416: ▲

b	4.0	5	6	11	11	12	16											
dk	6.0	9.0	10	13	16	16	18											
k	3.0	4.0	4.5	5.5	7	7	9											
s	2	2.5	3	4	5	5	6											
Thread	M3	M4	M5	M6	M6	M8	M10											
Length/d	4.0	5.0	6.0	8.0	10	10	12											
4	■▲	■▲	■▲															
5	■▲	■▲	■▲															
6	■▲	■▲	■▲	■▲														
8	■▲	■▲	■▲	■▲	■▲	■▲												
10	■▲	■▲	■▲	■▲	■▲	■▲												
12		■▲	■▲	■▲	■▲	■▲	■											
14		■▲	■▲															
16		■▲	■▲	■▲	■▲	■▲	■▲											
20		■▲	■▲	■▲			■▲											
25	■	■▲	■▲				■▲											
30		■▲	■▲															

[CLICK HERE TO RETURN TO THE CONTENTS PAGE](#)



+ 37 064 411 786



Inquiry@invayear.com

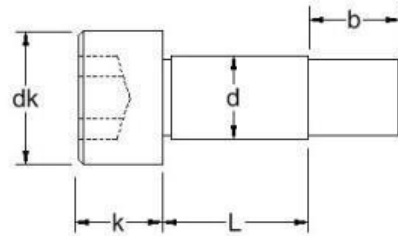
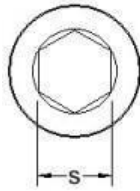

www.invayear.com

SOCKET SHOULDER SCREWS

Material grades: A2: ■ 416: ▲

b	5/32	3/16	3/16	3/8	1/4	7/16	7/16	1/2	5/8									
dk	1/4	9/32	5/16	3/8	3/8	7/16	9/16	9/16	3/4									
k	1/8	1/8	5/32	3/16	3/16	7/32	1/4	1/4	5/16									
s	5/64	3/32	3/32	1/8	1/8	5/32	3/16	3/16	1/4									
Thread	4-40	6-32	8-32	10-24	10-32	1/4-20	1/4-20	5/16-18	3/8-16									
Length/d	1/8	5/32	3/16	1/4	1/4	5/16	3/8	3/8	1/2									
1/8	■▲	■▲	■▲	■▲	■▲													
3/16	■▲	■▲	■▲	■▲	■▲													
1/4	■▲	■▲	■▲	■▲	■▲	■▲												
5/16	■▲	■▲	■▲	■▲	■▲	■▲	■▲	■▲										
3/8	■▲	■▲	■▲	■▲	■▲	■▲	■▲	■▲										
7/16	■▲	■▲																
1/2	■▲	■▲	■▲	■▲	■▲	■▲	■▲	■▲	■▲									
5/8			■▲	■▲	■▲	■▲	■▲	■▲	■▲									
3/4			■▲	■▲	■▲	■▲	■▲	■▲	■▲									
1			■▲	■▲	■▲	■▲	■▲	■▲	■▲									
1.1/4			■▲	■▲	■▲	■▲	■▲	■▲	■▲									
1.1/2			■▲	■▲	■▲	■▲	■▲	■▲	■▲									

CLICK HERE TO RETURN TO THE CONTENTS PAGE



+ 37 064 411 786



Inquiry@invayear.com

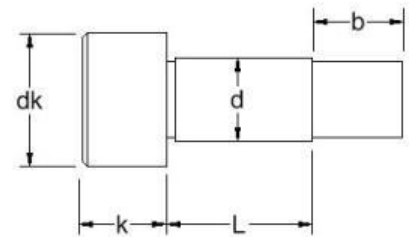
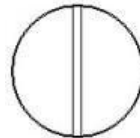

www.invayear.com

SHOULDER SCREWS
SLOTTED SHOULDER SCREWS

Material grades: A2:■

b	4	5	6	11	11	12	16											
dk	6.0	8.0	10	12	14	14	20											
k	3.0	4.0	5.0	6.0	7.0	7.0	8.0											
Thread	M3	M4	M5	M6	M6	M8	M10											
Length/d	4.0	5.0	6.0	8.0	10	10	12											
4	■	■	■															
5	■	■	■															
6	■	■	■	■														
8	■	■	■	■	■	■												
10	■	■	■	■	■	■												
12		■	■	■	■	■	■											
14		■	■															
16		■	■	■	■	■	■											
20		■	■	■														
25		■	■															
30		■	■															

CLICK HERE TO RETURN TO THE CONTENTS PAGE



+ 37 064 411 786



Inquiry@invayear.com

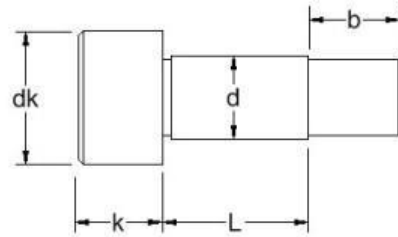
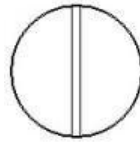

www.invayear.com

SLOTTED SHOULDER SCREWS

Material grades: A2: ■

b	5/32	3/16	3/16	3/8	1/4	7/16	7/16	1/2	5/8									
dk	1/4	9/32	5/16	3/8	3/8	7/16	9/16	9/16	3/4									
k	1/8	1/8	5/32	3/16	3/16	7/32	1/4	1/4	5/16									
Thread	4-40	6-32	8-32	10-24	10-32	1/4-20	1/4-20	5/16-18	3/8-16									
Length/d	1/8	5/32	3/16	1/4	1/4	5/16	3/8	3/8	1/2									
1/8	■	■	■	■	■													
3/16	■	■	■	■	■													
1/4	■	■	■	■	■	■												
5/16	■	■	■	■	■	■	■	■										
3/8	■	■	■	■	■	■	■	■	■									
7/16	■																	
1/2	■	■	■	■	■	■	■	■	■	■								
5/8			■	■	■	■	■	■	■	■								
3/4			■	■	■	■	■	■	■	■								
1			■	■	■	■	■	■	■	■								
1.1/4			■	■	■	■	■	■	■	■								
1.1/2			■	■	■	■	■	■	■	■								

[CLICK HERE TO RETURN TO THE CONTENTS PAGE](#)

+ 37 064 411 786

Inquiry@invayear.com

www.invayear.com

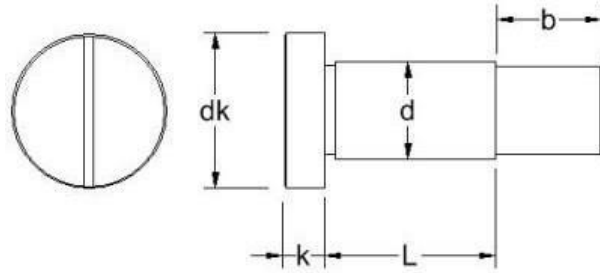
SHOULDER SCREWS
ULTRA LOW HEAD SLOTTED SHOULDER SCREWS

Material grades: A4: ♦

b	4	5	6	11															
dk	6.0	9.0	10	13															
k	1.3	1.3	1.7	2.0															
Thread	M3	M4	M5	M6															
Length/d	4.0	5.0	6.0	8.0															
4	♦	♦	♦																
5	♦	♦	♦																
6	♦	♦	♦	♦															
8	♦	♦	♦	♦															
10	♦	♦	♦	♦															
12		♦	♦	♦															
16		♦	♦	♦															
20		♦	♦	♦															

[CLICK HERE TO RETURN TO THE CONTENTS PAGE](#)

+ 37 064 411 786

Inquiry@invayear.com

www.invayear.com

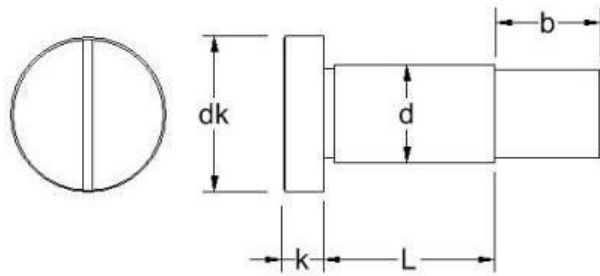
ULTRA LOW HEAD SLOTTED SHOULDER SCREWS

Material grades: A4: ♦

b	1/8	5/32	3/16	3/16	1/4													
dk	3/16	1/4	9/32	5/16	3/8													
k	1/32	3/64	3/64	3/64	1/16													
Thread	2-56	4-40	6-32	8-32	10-32													
Length/d	3/32	1/8	5/32	3/16	1/4													
1/8	♦	♦	♦	♦														
3/16	♦	♦	♦	♦														
1/4	♦	♦	♦	♦	♦													
5/16	♦	♦	♦	♦	♦													
3/8	♦	♦	♦	♦	♦													
1/2		♦	♦	♦	♦													
5/8				♦	♦													
3/4				♦	♦													
1				♦	♦													

[CLICK HERE TO RETURN TO THE CONTENTS PAGE](#)



+ 37 064 411 786

Inquiry@invayear.com

www.invayear.com

SHOULDER SCREWS

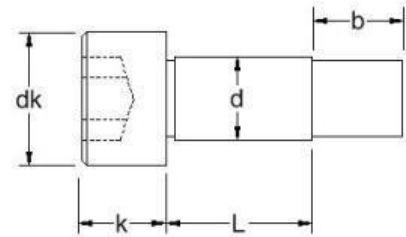
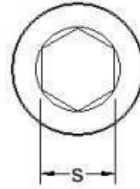
KNURLED SOCKET SHOULDER SCREWS



Material grades: A2: ■ A4: ◆

b	3.8	4.5	4.5	9.5	11	13	16	18	22										
dk	5.0	6.0	9.0	10	13	16	18	24	30										
k	2.0	3.0	4.0	4.5	5.5	7	9	11	14										
s	2.0	2	2.5	3	4	5	6	8	10										
Thread	M2	M3	M4	M5	M6	M8	M10	M12	M16										
Length/d	3.0	4.0	5.0	6.0	8.0	10	12	16	20										
4	◆	◆	◆	◆															
5	◆	◆	◆	◆															
6	◆	◆	◆	◆															
7		◆		◆															
8	◆	◆	◆	◆	◆	◆	◆												
10	◆	◆	◆	◆	◆	◆	◆												
12		◆	◆	◆	◆	◆	◆												
14		◆	◆	◆	◆	◆	◆												
16		◆	◆	◆	◆	◆	◆												
18		◆	◆	◆	◆	◆	◆												
20		◆	◆	◆	◆	◆	◆	◆											
25		◆	◆	◆	◆	◆	◆	◆	◆										
30		◆	◆	◆	◆	◆	◆	◆	◆										
35		◆	◆	◆	◆	◆	◆	◆	◆										
40		◆	◆	◆	◆	◆	◆	◆	◆	◆									
45		◆	◆	◆	◆	◆	◆	◆	◆										
50		◆	◆	◆	◆	◆	◆	◆	◆	◆									
55					◆	◆	◆	◆	◆										
60					◆	◆	◆	◆	◆	◆									
70					◆	◆	◆	◆	◆	◆									
80					◆	◆	◆	◆	◆	◆									
90					◆	◆	◆	◆	◆	◆									
100					◆	◆	◆	◆	◆	◆									
120										◆									

[CLICK HERE TO RETURN TO THE CONTENTS PAGE](#)



+ 37 064 411 786



Inquiry@invayear.com

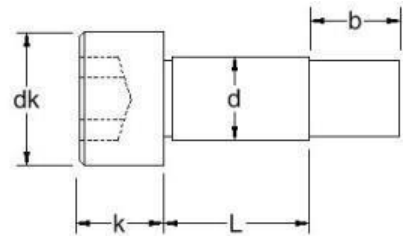
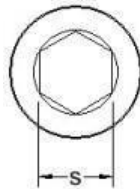

www.invayear.com

KNURLED SOCKET SHOULDER SCREWS

Material grades: A2: ■ A4: ◆

	b	5/32	3/16	3/16	3/16	3/8	1/4	7/16	3/4	1/2	5/8	3/4	7/8	1	1.1/8	1.1/2		
dk	1/4	9/32	5/16	5/16	3/8	3/8	7/16	9/16	9/16	3/4	7/8	1	1.5/16	1.3/4	2.1/8			
k	1/8	1/8	5/32	5/32	3/16	3/16	7/32	1/4	1/4	5/16	3/8	1/2	5/8	3/4	1			
s	5/64	3/32	3/32	3/16	1/8	1/8	5/32	3/16	3/16	1/4	5/16	3/8	1/2	5/8	7/8			
Thread	4-40	6-32	8-32	8-32	10-24	10-32	1/4-20	1/4-20	5/16-18	3/8-16	1/2-13	5/8-11	3/4-10	7/8-9	1.1/8-7			
Length/d	1/8	5/32	3/16	7/32	1/4	1/4	5/16	3/8	3/8	1/2	5/8	3/4	1	1.1/4	1.1/2			
1/8	■◆	■◆	■◆	■◆	■◆	■◆	■◆											
5/32	■◆	■◆	■◆	■◆	■◆	■◆	■◆											
3/16	■◆	■◆	■◆	■◆	■◆	■◆	■◆	■◆	■◆									
7/32	■◆	■◆	■◆	■◆	■◆	■◆	■◆	■◆	■◆									
1/4	■◆	■◆	■◆	■◆	■◆	■◆	■◆	■◆	■◆	■◆	■◆							
9/32	■◆	■◆	■◆	■◆	■◆	■◆	■◆	■◆	■◆	■◆	■◆							
5/16	■◆	■◆	■◆	■◆	■◆	■◆	■◆	■◆	■◆	■◆	■◆							
11/32	■◆	■◆	■◆	■◆	■◆	■◆	■◆	■◆	■◆	■◆	■◆							
3/8	■◆	■◆	■◆	■◆	■◆	■◆	■◆	■◆	■◆	■◆	■◆							
13/32	■◆	■◆	■◆	■◆	■◆	■◆	■◆	■◆	■◆	■◆	■◆							
7/16	■◆	■◆	■◆	■◆	■◆	■◆	■◆	■◆	■◆	■◆	■◆							
15/32	■◆	■◆	■◆	■◆	■◆	■◆	■◆	■◆	■◆	■◆	■◆							
1/2	■◆	■◆	■◆	■◆	■◆	■◆	■◆	■◆	■◆	■◆	■◆	■◆	■◆	■◆				
9/16	■◆	■◆	■◆	■◆	■◆	■◆	■◆	■◆	■◆	■◆	■◆							
5/8	■◆	■◆	■◆	■◆	■◆	■◆	■◆	■◆	■◆	■◆	■◆	■◆	■◆	■◆				

CLICK HERE TO RETURN TO THE CONTENTS PAGE



+ 37 064 411 786



Inquiry@invayear.com



www.invayear.com

SHOULDER SCREWS

KNURLED SOCKET SHOULDER SCREWS

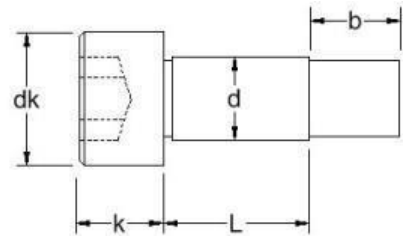
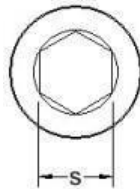

Material grades: A2: ■ A4: ◆

	b	5/32	3/16	3/16	3/16	3/8	1/4	7/16	3/4	1/2	5/8	3/4	7/8	1	1.1/8	1.1/2		
dk	1/4	9/32	5/16	5/16	3/8	3/8	7/16	9/16	9/16	3/4	7/8	1	1.5/16	1.3/4	2.1/8			
k	1/8	1/8	5/32	5/32	3/16	3/16	7/32	1/4	1/4	5/16	3/8	1/2	5/8	3/4	1			
s	5/64	3/32	3/32	3/16	1/8	1/8	5/32	3/16	3/16	1/4	5/16	3/8	1/2	5/8	7/8			
Thread	4-40	6-32	8-32	8-32	10-24	10-32	1/4-20	1/4-20	5/16-18	3/8-16	1/2-13	5/8-11	3/4-10	7/8-9	1.1/8-7			
Length/d	1/8	5/32	3/16	7/32	1/4	1/4	5/16	3/8	3/8	1/2	5/8	3/4	1	1.1/4	1.1/2			
1.1/16	◆	◆	◆	◆	◆	◆	◆	◆	◆									
3/4	◆	◆	◆	◆	◆	◆	◆	◆	◆	◆	◆	◆	◆					
1.3/16	◆	◆	◆	◆	◆	◆	◆	◆	◆									
7/8	◆	◆	◆	◆	◆	◆	◆	◆	◆	◆	◆							
1.5/16	◆	◆	◆	◆	◆	◆	◆	◆	◆									
1	◆	◆	◆	◆	◆	◆	◆	◆	◆	◆	◆	◆	◆	◆	◆	◆		
1.1/8	◆	◆	◆	◆	◆	◆	◆	◆	◆	◆	◆	◆	◆	◆	◆	◆		
1.1/4	◆	◆	◆	◆	◆	◆	◆	◆	◆	◆	◆	◆	◆	◆	◆	◆		
1.3/8	◆	◆	◆	◆	◆	◆	◆	◆	◆									
1.1/2	◆	◆	◆	◆	◆	◆	◆	◆	◆	◆	◆	◆	◆	◆	◆	◆		
1.5/8	◆	◆	◆	◆	◆	◆	◆	◆	◆									
1.3/4	◆	◆	◆	◆	◆	◆	◆	◆	◆	◆	◆	◆	◆	◆	◆	◆		
1.7/8	◆	◆	◆	◆	◆	◆	◆	◆	◆									
2	◆	◆	◆	◆	◆	◆	◆	◆	◆	◆	◆	◆	◆	◆	◆	◆		
2.1/4			◆	◆	◆	◆	◆	◆	◆	◆	◆	◆	◆	◆	◆			

[CLICK HERE TO RETURN TO THE CONTENTS PAGE](#)



+ 37 064 411 786



Inquiry@invayear.com



www.invayear.com

KNURLED SOCKET SHOULDER SCREWS

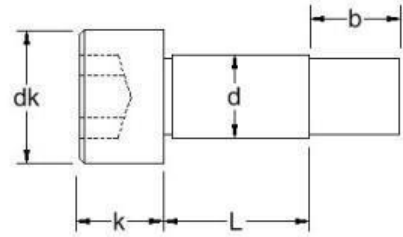
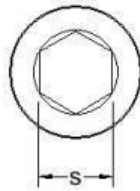

Material grades: A2: ■ A4: ◆

	5/32	3/16	3/16	3/16	3/8	1/4	7/16	3/4	1/2	5/8	3/4	7/8	1	1.1/8	1.1/2		
b	5/32	3/16	3/16	3/16	3/8	1/4	7/16	3/4	1/2	5/8	3/4	7/8	1	1.1/8	1.1/2		
dk	1/4	9/32	5/16	5/16	3/8	3/8	7/16	9/16	9/16	3/4	7/8	1	1.5/16	1.3/4	2.1/8		
k	1/8	1/8	5/32	5/32	3/16	3/16	7/32	1/4	1/4	5/16	3/8	1/2	5/8	3/4	1		
s	5/64	3/32	3/32	3/16	1/8	1/8	5/32	3/16	3/16	1/4	5/16	3/8	1/2	5/8	7/8		
Thread	4-40	6-32	8-32	8-32	10-24	10-32	1/4-20	1/4-20	5/16-18	3/8-16	1/2-13	5/8-11	3/4-10	7/8-9	1.1/8-7		
Length/d	1/8	5/32	3/16	7/32	1/4	1/4	5/16	3/8	3/8	1/2	5/8	3/4	1	1.1/4	1.1/2		
2.1/2			■◆	■◆	■◆	■◆	■◆	■◆	■◆	■◆	■◆	■◆	■◆	■◆	■◆		
2.3/4					■◆	■◆	■◆	■◆	■◆	■◆	■◆	■◆	■◆	■◆			
3					■◆	■◆	■◆	■◆	■◆	■◆	■◆	■◆	■◆	■◆	■◆		
3.1/4								■◆	■◆	■◆	■◆	■◆	■◆	■◆			
3.1/2					■◆	■◆	■◆	■◆	■◆	■◆	■◆	■◆	■◆	■◆	■◆		
3.3/4								■◆	■◆	■◆	■◆	■◆	■◆	■◆	■◆		
4					■◆	■◆	■◆	■◆	■◆	■◆	■◆	■◆	■◆	■◆	■◆		
4.1/4										■◆	■◆	■◆	■◆	■◆			
4.1/2					■◆	■◆	■◆	■◆	■◆	■◆	■◆	■◆	■◆	■◆	■◆		
4.3/4										■◆	■◆	■◆	■◆	■◆			
5					■◆	■◆	■◆	■◆	■◆	■◆	■◆	■◆	■◆	■◆	■◆		
5.1/2							■◆	■◆	■◆	■◆	■◆	■◆	■◆	■◆	■◆		
6							■◆	■◆	■◆	■◆	■◆	■◆	■◆	■◆	■◆		
6.1/2								■◆	■◆	■◆	■◆	■◆	■◆	■◆	■◆		
7								■◆	■◆	■◆	■◆	■◆	■◆	■◆	■◆		
7.1/2								■◆	■◆	■◆	■◆	■◆	■◆	■◆	■◆		
8								■◆	■◆	■◆	■◆	■◆	■◆	■◆	■◆		

CLICK HERE TO RETURN TO THE CONTENTS PAGE



+ 37 064 411 786



Inquiry@invayear.com



www.invayear.com

SHOULDER SCREWS

LOW HEAD SLOTTED SHOULDER SCREWS

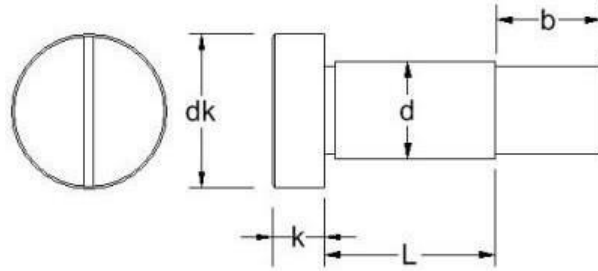

Material grades: A2: ■ A4: ◆

	1/8	5/32	3/16	3/16	1/4	7/16	1/2											
b	1/8	5/32	3/16	3/16	1/4	7/16	1/2											
dk	3/16	1/4	9/32	5/16	3/8	7/16	9/16											
k	1/16	3/32	5/64	7/64	1/8	1/8	3/32											
Thread	2-56	4-40	6-32	8-32	10-32	1/4-20	5/16-18											
Length/d	3/32	1/8	5/32	3/16	1/4	5/16	3/8											
1/16	■◆	■◆																
3/32	■◆	■◆																
1/8	■◆	■◆	■◆	■◆	■◆	■◆												
5/32	■◆	■◆																
3/16	■◆	■◆	■◆	■◆	■◆													
1/4	■◆	■◆	■◆	■◆	■◆	■◆	■◆											
5/16	■◆	■◆	■◆	■◆	■◆													
3/8	■◆	■◆	■◆	■◆	■◆	■◆	■◆											
1/2		■◆		■◆	■◆	■◆	■◆											
5/8				■◆	■◆	■◆	■◆											
3/4				■◆	■◆	■◆	■◆											
1				■◆	■◆	■◆	■◆											

[CLICK HERE TO RETURN TO THE CONTENTS PAGE](#)



+ 37 064 411 786



Inquiry@invayear.com

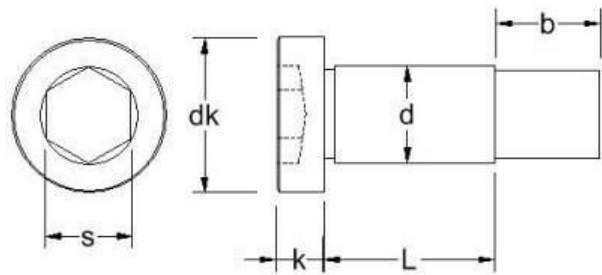

www.invayear.com

LOW HEAD SOCKET SHOULDER SCREWS

Material grades: A2: ■ A4: ◆

b	1/8	5/32	3/16	3/16	1/4	7/16	1/2												
dk	3/16	1/4	9/32	5/16	3/8	7/16	9/16												
k	1/16	3/32	5/64	7/64	1/8	1/8	3/32												
s	5/64	5/64	3/32	3/32	1/8	5/32	3/16												
Thread	2-56	4-40	6-32	8-32	10-32	1/4-20	5/16-18												
Length/d	3/32	1/8	5/32	3/16	1/4	5/16	3/8												
1/16	■◆	■◆																	
3/32	■◆	■◆																	
1/8	■◆	■◆	■◆	■◆	■◆	■◆													
5/32	■◆	■◆																	
3/16	■◆	■◆	■◆	■◆	■◆														
1/4	■◆	■◆	■◆	■◆	■◆	■◆	■◆												
5/16	■◆	■◆	■◆	■◆	■◆														
3/8	■◆	■◆	■◆	■◆	■◆	■◆	■◆	■◆											
1/2		■◆		■◆	■◆	■◆	■◆	■◆											
5/8				■◆	■◆	■◆	■◆	■◆											
3/4				■◆	■◆	■◆	■◆	■◆											
1				■◆	■◆	■◆	■◆												

[CLICK HERE TO RETURN TO THE CONTENTS PAGE](#)

+ 37 064 411 786

Inquiry@invayear.com

www.invayear.com

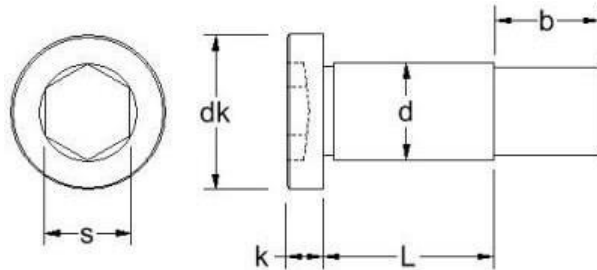
ULTRA LOW HEAD SOCKET SHOULDER SCREWS

Material grades: A4: ◆

b	1/8	5/32	3/16	3/16	1/4													
dk	3/16	1/4	9/32	5/16	3/8													
k	1/32	3/64	3/64	3/64	1/16													
s	5/64	5/64	3/32	3/32	1/8													
Thread	2-56	4-40	6-32	8-32	10-32													
Length/d	3/32	1/8	5/32	3/16	1/4													
1/8	◆	◆	◆	◆														
3/16	◆	◆	◆	◆														
1/4	◆	◆	◆	◆	◆													
5/16		◆	◆	◆	◆													
3/8	◆	◆	◆	◆	◆													
1/2		◆	◆	◆	◆													
5/8				◆	◆													
3/4				◆	◆													
1				◆	◆													

[CLICK HERE TO RETURN TO THE CONTENTS PAGE](#)

+ 37 064 411 786

Inquiry@invayear.com

www.invayear.com

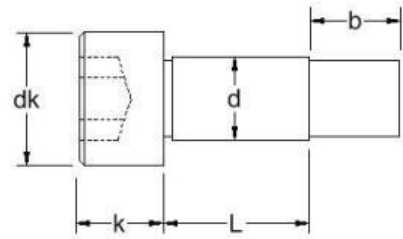
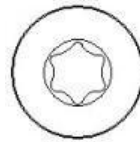
SHOULDER SCREWS
TX SHOULDER SCREWS

Material grades: A2: ■ A4: ◆

b	5/32	3/16	1/4															
dk	1/4	5/16	3/8															
k	1/8	5/32	3/16															
T Drive	T10	T25	T30															
Thread	4-40	8-32	10-32															
Length/d	1/8	3/16	1/4															
1/8	■◆	■◆	■◆															
3/16	■◆	■◆	■◆															
1/4	■◆	■◆	■◆															
5/16	■◆	■◆	■◆															
3/8	■◆	■◆	■◆															
1/2	■◆	■◆	■◆															
5/8		■◆	■◆															
3/4		■◆	■◆															
1		■◆	■◆															

CLICK HERE TO RETURN TO THE CONTENTS PAGE



+ 37 064 411 786



Inquiry@invayear.com

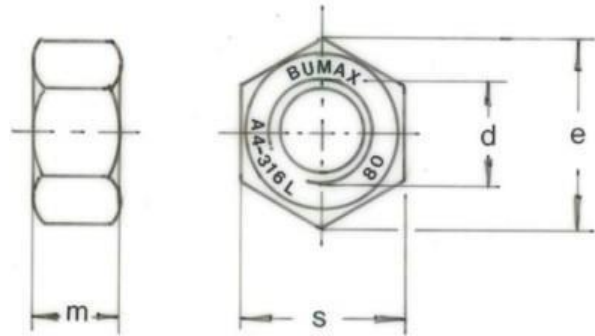

www.invayear.com

BUMAX HEXAGON FULL NUTS ISO 4032

Material grades: BUMAX 88:✘ BUMAX 109:★

e	11.5	14.95	18.4	20.7	24.15	27.6	31.05	34.5	41.4	47.15	52.9	63.25						
m (Max)	5.2	6.8	8.4	10.8	12.8	14.8	15.8	18	21.5	23.8	25.6	31						
Pitch	1.00	1.25	1.50	1.75	2.00	2.00	2.50	2.50	3.00	3.00	3.50	4.00						
s (Max)	10	13	16	18	21	24	27	30	36	41	46	55						
Length/dim	M6	M8	M10	M12	M14	M16	M18	M20	M24	M27	M30	M36						
	✘★	✘★	✘★	✘★	✘★	✘★	✘	✘	✘	✘	✘	✘						

[CLICK HERE TO RETURN TO THE CONTENTS PAGE](#)



+ 37 064 411 786

Inquiry@invayear.com

www.invayear.com

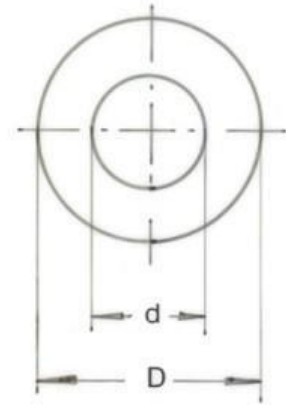

Material grades: BUMAX 88:✘ BUMAX 109:★

D	9	10	12	16	20	24		30	37	39	44	50	56	66			
d	4.3	5.3	6.4	8.4	10.5	13		17	21	23	25	28	31	37			
t	0.8	1	1.6	1.6	2	2.5		3	3	3	4	4	4	5			
Length/dim	M4	M5	M6	M8	M10	M12	M14	M16	M20	M22	M24	M27	M30	M36			
	✘★	✘★	✘★	✘★	✘★	✘★	✘★	✘★	✘★	✘	✘★	✘	✘	✘			

CLICK HERE TO RETURN TO THE CONTENTS PAGE



+ 37 064 411 786



Inquiry@invayear.com



www.invayear.com

BUMAX SOCKET CAP SCREWS ISO 4762

Material grades: BUMAX 88:✘ BUMAX 109:★

	18	20	22	24	28	32	36	44	52	60						
b (Max)	18	20	22	24	28	32	36	44	52	60						
dk	5.5	7.0	8.5	10	13	16	18	24	30	36						
k (Max)	3	4	5	6	8	10	12	16	20	24						
Pitch	0.5	0.7	0.8	1.0	1.25	1.5	1.75	2.0	2.5	3.0						
s	2.5	3	4	5	6	8	10	14	17	19						
t (Min)	1.3	2.0	2.5	3	4	5	6	8	10	12						
Length/dim	M3	M4	M5	M6	M8	M10	M12	M16	M20	M24						
6	✘	✘														
8	✘	✘														
10	✘	✘	✘													
12	✘	✘★	✘	✘★												
14		✘		✘★												
16	✘	✘★	✘	✘★	✘★	✘										
20	✘	✘★	✘	✘★	✘★	✘★	✘									
22				✘	✘	★										
25	✘	✘	✘	✘★	✘★	✘★	✘★									
30	✘	✘	✘	✘★	✘★	✘★	✘★	✘	✘							
35	✘	✘	✘	✘★	✘★	✘★	✘★	✘								
40		✘★	✘	✘★	✘★	✘★	✘★	✘★	✘★	✘						
45		✘	✘	✘★	✘★	✘★	✘★	✘	✘							
50		✘	✘	✘★	✘★	✘★	✘★	✘★	✘	✘						

CLICK HERE TO RETURN TO THE CONTENTS PAGE



+ 37 064 411 786



Inquiry@invayear.com



www.invayear.com

BUMAX SOCKET CAP SCREWS ISO 4762

 Material grades: **BUMAX 88:** ✕ **BUMAX 109:** ★

b (Max)	18	20	22	24	28	32	36	44	52	60										
dk	5.5	7.0	8.5	10	13	16	18	24	30	36										
k (Max)	3	4	5	6	8	10	12	16	20	24										
Pitch	0.5	0.7	0.8	1.0	1.25	1.5	1.75	2.0	2.5	3.0										
s	2.5	3	4	5	6	8	10	14	17	19										
t (Min)	1.3	2.0	2.5	3	4	5	6	8	10	12										
Length/dim	M3	M4	M5	M6	M8	M10	M12	M16	M20	M24										
55		✕	✕	✕★	✕★	✕	✕★	✕												
60			✕	✕★	✕★	✕★	✕★	✕	✕	✕										
65				✕★	✕★	✕★	✕	✕		✕										
70			✕	✕★	✕★	✕★	✕★	✕	✕	✕										
73			✕																	
75				✕★	✕★	✕★	✕★		✕											
80		✕		✕★	✕★	✕★	✕★	✕★	✕	✕										
90				✕	✕★	✕★	✕★	✕★	✕	✕										
100			✕	✕	✕	✕★	✕★	✕★	✕	✕										
110						✕★	✕★	✕	✕	✕										
115							✕													
120						✕	✕★	✕	✕	✕										
125							✕													
130							✕	✕★	✕	✕										
135								✕												
140							✕	✕	✕★	✕										
150							✕	✕	✕	✕										
160									✕											
170										✕										
180									✕											
190									✕											

CLICK HERE TO RETURN TO THE CONTENTS PAGE



+ 37 064 411 786



Inquiry@invayear.com

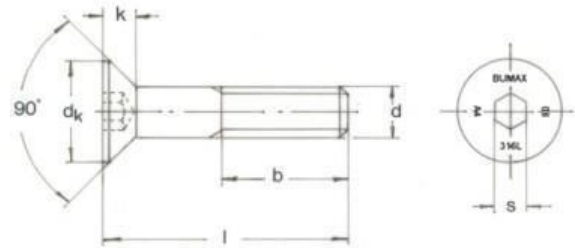

www.invayear.com

BUMAX SOCKET COUNTERSUNK SCREWS ISO 10642

 Material grades: **BUMAX 88:✕**

dk (Max)	6.72	8.96	11.20	13.44	17.92	22.40	26.88	30.88										
k (Max)	1.86	2.48	3.1	3.72	4.96	6.2	7.44	8.8										
Pitch	0.5	0.7	0.8	1.0	1.25	1.5	1.75	2.0										
s	2	2.5	3	4	5	6	8	10										
τ (Min)	1.1	1.5	1.9	2.2	3.0	3.6	4.3	4.8										
Length/dim	M3	M4	M5	M6	M8	M10	M12	M16										
6	✕																	
8	✕																	
10	✕	✕	✕	✕														
12	✕	✕	✕	✕	✕													
14					✕													
16	✕	✕	✕	✕	✕													
20	✕	✕	✕	✕	✕	✕												
25		✕	✕	✕	✕	✕												
30		✕	✕	✕	✕	✕	✕											
35					✕	✕												
40				✕	✕	✕	✕	✕										
45						✕	✕											
50				✕	✕	✕	✕	✕										
60				✕	✕		✕	✕										
70					✕		✕	✕										
80								✕										
100								✕										

[CLICK HERE TO RETURN TO THE CONTENTS PAGE](#)



+ 37 064 411 786



Inquiry@invayear.com

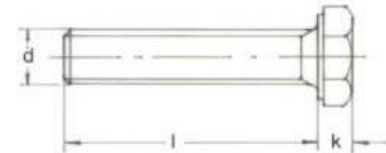
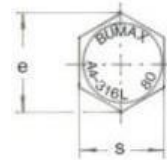

www.invayear.com

 Material grades: **BUMAX 88:** ✕ **BUMAX 109:** ★

e	s x 1.15	s x 1.15	s x 1.15	s x 1.15	s x 1.15	s x 1.15	s x 1.15	s x 1.15	s x 1.15	s x 1.15	s x 1.15	s x 1.15	s x 1.15	s x 1.15			
k (Max)	2.925	3.65	4.15	5.45	6.58	7.68	8.98	10.18	11.715	12.715	15.215	17.35	19.12	22.92			
Pitch	0.7	0.8	1.0	1.25	1.5	1.75	2.0	2.0	2.5	2.5	3.0	3.0	3.5	4.0			
s (Max)	7	8	10	13	16	18	21	24	27	30	36	41	46	55			
Length/dim	M4	M5	M6	M8	M10	M12	M14	M16	M18	M20	M24	M27	M30	M36			
6	✕																
8	✕																
10	✕	✕	✕	✕													
12	✕	✕	✕★	✕	✕												
14		✕	✕	✕	★												
16	✕★	✕	✕★	✕	✕★												
20	✕★	✕	✕★	✕★	✕★	✕★											
22			✕★	✕★													
25	✕	✕	✕★	✕★	✕★	✕★		✕									
30	✕	✕	✕★	✕★	✕★	✕★	✕	✕★		✕							
32						✕											
35		✕	✕	✕★	✕★	✕★	✕	✕★		✕							
40		✕	✕	✕	✕★	✕★	✕	✕★	✕	✕	✕						
45		✕	✕	✕	✕	✕		✕★		✕	✕						
50		✕	✕	✕	✕	✕	✕	✕★	✕	✕	✕	✕					
55			✕	✕	✕	✕		✕★		✕	✕						

CLICK HERE TO RETURN TO THE CONTENTS PAGE



+ 37 064 411 786



Inquiry@invayear.com

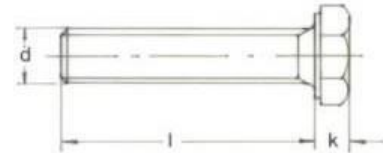
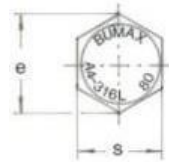

www.invayear.com

BUMAX HEXAGON SET SCREWS ISO 4017

 Material grades: **BUMAX 88:** ✖ **BUMAX 109:** ★

e	s x l.15	s x l.15	s x l.15	s x l.15	s x l.15	s x l.15	s x l.15	s x l.15	s x l.15	s x l.15	s x l.15	s x l.15	s x l.15	s x l.15			
k (Max)	2.925	3.65	4.15	5.45	6.58	7.68	8.98	10.18	11.715	12.715	15.215	17.35	19.12	22.92			
Pitch	0.7	0.8	1.0	1.25	1.5	1.75	2.0	2.0	2.5	2.5	3.0	3.0	3.5	4.0			
s (Max)	7	8	10	13	16	18	21	24	27	30	36	41	46	55			
Length/dim	M4	M5	M6	M8	M10	M12	M14	M16	M18	M20	M24	M27	M30	M36			
60			✖	✖	✖	✖	✖	✖★	✖	✖	✖	✖	✖				
65			★	★	✖	✖				✖	✖						
70			✖	✖★	✖	✖	✖	✖	✖	✖	✖	✖	✖				
75										✖	✖						
80			✖	✖	✖	✖		✖	✖	✖	✖	✖	✖	✖			
90					✖	✖		✖★		✖	✖	✖	✖	✖			
100					✖	✖		✖		✖	✖	✖	✖	✖			
110					✖						✖						
120					✖			✖			✖	✖	✖	✖			
130					✖					✖			✖	✖			
140											✖	✖	✖	✖			
150										✖		✖		✖			

CLICK HERE TO RETURN TO THE CONTENTS PAGE



+ 37 064 411 786



Inquiry@invayear.com

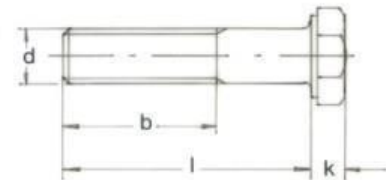
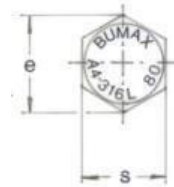

www.invayear.com

BUMAX HEXAGON BOLTS ISO 4014

 Material grades: **BUMAX 88:** ✖ **BUMAX 109:** ★

	18	22	26	30	34	38	42	46	54	60	66	78					
b (Max)	18	22	26	30	34	38	42	46	54	60	66	78					
b (Max) (L > 125mm)	24	28	32	36	40	44	48	52	60	66	72	84					
k (Min)	3.76	5.06	6.11	7.21	8.51	9.71	11.15	12.15	14.65	16.65	18.28	22.08					
Pitch	1.0	1.25	1.5	1.75	2.0	2.0	2.5	2.5	3.0	3.0	3.5	4.0					
s (Max)	10	13	16	18	21	24	27	30	36	41	46	55					
Length/dim	M6	M8	M10	M12	M14	M16	M18	M20	M24	M27	M30	M36					
30	✖★																
35	✖★	✖★		★													
40	✖★	✖★	✖	✖★													
42	✖																
45	✖★	✖★	✖★	✖★													
50	✖★	✖★	✖★	✖★		✖											
55	✖★	✖★	✖★	✖★		✖											
60	✖★	✖★	✖★	✖★		✖★		✖									
65	✖★	✖★	✖★	✖★		✖★		✖									
70	✖★	✖★	✖★	✖★		✖★	✖	✖									
75	★	✖	✖	✖		✖★		✖	✖			✖					
80	✖★	✖★	✖★	✖★	✖★	✖★	✖	✖	✖			✖					
85			✖														
90	✖	✖	✖★	✖★	✖	✖★	✖	✖	✖			✖					
100	✖	✖	✖★	✖★	✖	✖★	✖	✖	✖	✖	✖	✖					

CLICK HERE TO RETURN TO THE CONTENTS PAGE



+ 37 064 411 786



Inquiry@invayear.com

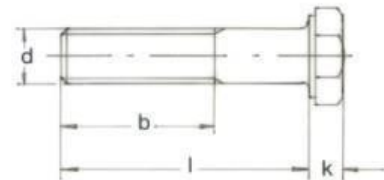
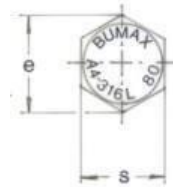

www.invayear.com

BUMAX HEXAGON BOLTS ISO 4014

Material grades: BUMAX 88:✘ BUMAX 109:★

b (Max)	18	22	26	30	34	38	42	46	54	60	66	78				
b (Max) (L >125mm)	24	28	32	36	40	44	48	52	60	66	72	84				
k (Min)	3.76	5.06	6.11	7.21	8.51	9.71	11.15	12.15	14.65	16.65	18.28	22.08				
Pitch	1.0	1.25	1.5	1.75	2.0	2.0	2.5	2.5	3.0	3.0	3.5	4.0				
s (Max)	10	13	16	18	21	24	27	30	36	41	46	55				
Length/dim	M6	M8	M10	M12	M14	M16	M18	M20	M24	M27	M30	M36				
110			✘	✘		✘★		✘	✘	✘	✘					
120			✘	✘★	✘	✘★	✘	✘	✘	✘	✘	✘				
130			✘	✘		✘		✘	✘	✘	✘	✘				
140				✘	✘	✘	✘	✘	✘	✘	✘	✘				
150			✘	✘		✘	✘	✘	✘	✘	✘	✘				
160			✘	✘		✘		✘	✘	✘	✘	✘				
170						✘			✘	✘						
180				✘		✘		✘	✘	✘	✘	✘				
200						✘		✘	✘	✘	✘	✘				
210												✘				
220									✘							
235											✘					
310									✘							
340									✘							

[CLICK HERE TO RETURN TO THE CONTENTS PAGE](#)

+ 37 064 411 786

Inquiry@invayear.com

www.invayear.com

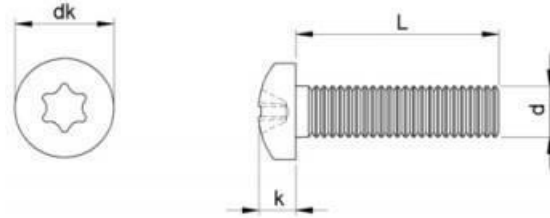
 Material grades: **BUMAX 88**

dk (Max)	12	16	20																	
k (Max)	4.6	6.0	7.5																	
Pitch	1.0	1.25	1.5																	
Length/dim	M6	M8	M10																	
6	✘																			
12		✘																		
16		✘																		
18		✘																		
20		✘																		
25		✘	✘																	
30		✘	✘																	
35		✘																		
40		✘	✘																	
45		✘																		
50		✘	✘																	
60		✘	✘																	
70		✘	✘																	
80		✘	✘																	
90			✘																	
100		✘	✘																	
120			✘																	

CLICK HERE TO RETURN TO THE CONTENTS PAGE



+ 37 064 411 786



Inquiry@invayear.com

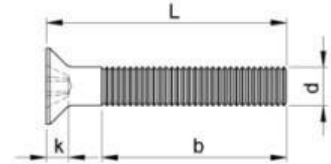
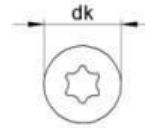

www.invayear.com

BUMAX TORX COUNTERSUNK MACHINE SCREWS ISO 14581

 Material grades: **BUMAX 88:**

Length/dim	M8	M10																	
dk (Max)	15.8	18.3																	
k (Max)	4.65	5.0																	
Pitch	1.25	1.5																	
10	✘																		
11	✘																		
12	✘																		
16	✘																		
20	✘	✘																	
25	✘	✘																	
30	✘	✘																	
35	✘	✘																	
40	✘	✘																	
50	✘	✘																	
60	✘	✘																	
70	✘	✘																	
80	✘	✘																	
90		✘																	
100	✘	✘																	
140		✘																	
150		✘																	

CLICK HERE TO RETURN TO THE CONTENTS PAGE



+ 37 064 411 786



Inquiry@invayear.com

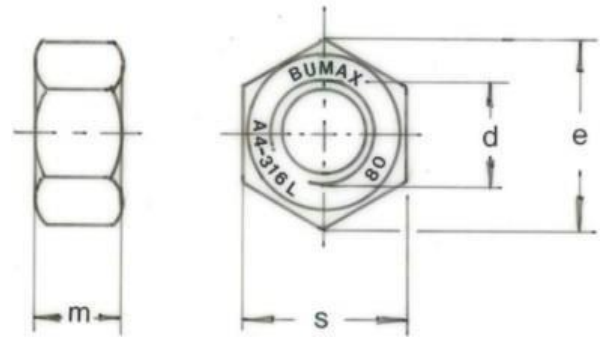

www.invayear.com

 Material grades: **BUMAX 88** ✕

e	s x 1.15	s x 1.15	s x 1.15	s x 1.15	s x 1.15	s x 1.15	s x 1.15										
m (Max)	0.226	0.273	0.337	0.887	0.559	0.665	0.776										
s (Max)	0.438	0.500	0.562	1.500	0.938	1.125	1.312										
T.P.I UNC	20	18	16	8	11	10	9										
Length/dim	1/4-20	5/16-18	3/8-16	1/2-13	5/8-11	3/4-10	7/8-9	1-8									
	✕	✕	✕	✕	✕	✕	✕	✕									

CLICK HERE TO RETURN TO THE CONTENTS PAGE



+ 37 064 411 786



Inquiry@invayear.com

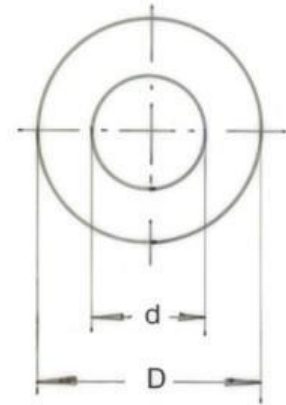

www.invayear.com

BUMAX FLAT WASHERS ANSI B18.22.1 200HV

 Material grades: **BUMAX 88** ✕

D	0.625	0.750	0.875	1.250	1.500	1.875	2.00	2.00										
d	0.281	0.343	0.406	0.531	0.687	0.812	0.937	1.062										
t	0.050	0.050	0.050	0.062	0.078	0.109	0.109	0.125										
Length/dim	1/4	5/16	3/8	1/2	5/8	3/4	7/8	1										
	✕	✕	✕	✕	✕	✕	✕	✕										

[CLICK HERE TO RETURN TO THE CONTENTS PAGE](#)



+ 37 064 411 786

Inquiry@invayear.com

www.invayear.com

 Material grades: **BUMAX 88**

	1.00 - 1.50	1.12 - 1.71	1.25 - 1.94	2.50 - 4.12	1.75 - 2.82	2.00 - 3.25	2.25 - 3.69								
b															
dk (Max)															
k (Max)															
s															
T.P.I UNC															
t (Min)															
Length/dim	1/4-20	5/16-18	3/8-16	1/2-13	5/8-11	3/4-10	7/8-9	1-8							
1/2	✘	✘													
5/8	✘	✘													
3/4	✘	✘	✘												
7/8	✘	✘	✘												
1	✘	✘	✘	✘											
1.1/4	✘	✘	✘	✘	✘										
1.1/2	✘	✘	✘	✘	✘										
1.3/4			✘		✘										
2		✘	✘	✘	✘	✘	✘	✘							
2.1/4				✘	✘										
2.1/2			✘	✘	✘	✘									
3				✘	✘	✘	✘	✘							
4					✘		✘	✘							

CLICK HERE TO RETURN TO THE CONTENTS PAGE



+ 37 064 411 786



Inquiry@invayear.com

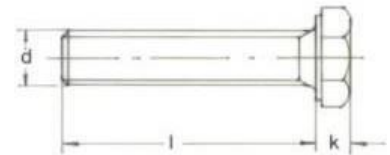
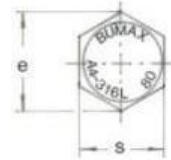

www.invayear.com

BUMAX HEXAGON SET SCREWS ANSI B18.2.1

 Material grades: **BUMAX 88**

k (Max)	0.163	0.211	0.243	0.627	0.403	0.483											
s (Max)	0.438	0.500	0.562	1.500	0.938	1.125											
T.P.I UNC	20	18	16	8	11	10											
Length/dim	1/4-20	5/16-18	3/8-16	1/2-13	5/8-11	3/4-10	1-8										
1/2	✘	✘															
5/8	✘	✘	✘														
3/4	✘	✘	✘														
7/8			✘														
1		✘	✘	✘	✘												
1.1/4				✘	✘	✘											
1.1/2				✘	✘	✘											
1.3/4					✘	✘											
2						✘	✘										
2.1/4							✘										
2.1/2							✘										

CLICK HERE TO RETURN TO THE CONTENTS PAGE



+ 37 064 411 786



Inquiry@invayear.com

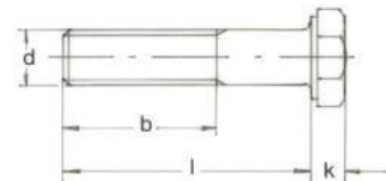

www.invayear.com

 Material grades: **BUMAX 88:**

k (Max)	0.163	0.211	0.243	0.323	0.403	0.483	0.563	0.627									
s (Max)	0.438	0.500	0.562	0.750	0.938	1.125	1.312	1.500									
Length/dim	1/4-20	5/16-18	3/8-16	1/2-13	5/8-11	3/4-10	7/8-9	1-8									
1	✘																
1.1/4	✘	✘	✘														
1.1/2	✘	✘	✘														
1.3/4	✘	✘	✘	✘													
2	✘	✘	✘	✘	✘												
2.1/4			✘	✘	✘	✘											
2.1/2	✘	✘	✘	✘	✘	✘	✘										
2.3/4			✘	✘	✘	✘	✘										
3	✘	✘	✘	✘	✘	✘	✘	✘									
3.1/4			✘	✘	✘	✘	✘	✘									
3.1/2		✘	✘	✘	✘	✘		✘									
4		✘	✘	✘	✘	✘	✘	✘									
4.1/2			✘	✘	✘	✘	✘	✘									
5			✘	✘	✘	✘	✘	✘									
5.1/2				✘	✘	✘		✘									
6			✘	✘	✘	✘	✘	✘									
6.1/2						✘		✘									
7						✘											

CLICK HERE TO RETURN TO THE CONTENTS PAGE



+ 37 064 411 786



Inquiry@invayear.com



www.invayear.com



www.invayear.com



+ 370 644 11 786



Inquiry@invayear.com